

GL-Connection (GL-Config)

Application software

USER'S MANUAL

MANUAL NO. APS(GL-Connection)-UM-160-01

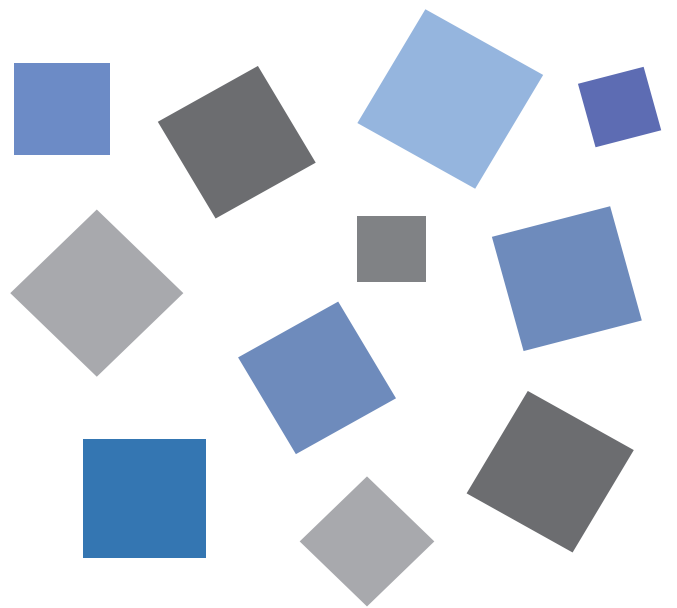

GRAPHTEC

Table of contents

1. PREFACE	9
1-1. Usage Notes	9
1-2. Trademarks.....	9
1-3. Copyright.....	9
1-4. Usage procedure	9
1-5. About GL-Config	10
1-6. About GL-Connection	10
2. Operation Environment for GL-Config and GL-Connection	12
3. Installing the USB Driver	13
4. Installing GL-Config and GL-Connection	14
5. How to Connect to a PC	15
5-1. Connecting using USB.....	15
5-2. Connecting using a LAN	17
5-3. Setting the USB ID or the IP Address	19
5-3-1. When setting the GL7000 with the GL-Config	19
5-3-2. When setting the GL7000 with the display module.....	19
5-3-3. When setting the USB connection to the GL860, GL260, GL980, GL2000, GL240 or GL840	20
5-3-4. When setting the USB connection to the GLT400	21
5-3-5. When setting the LAN connection to the GL980, GL2000	22
5-3-6. When setting the LAN connection to the GL840.....	22
5-3-7. When setting the LAN connection to the GL860.....	23
5-3-8. When setting the LAN connection to the GLT400	23
5-3-9. PC TCP-IP Settings	24
5-3-10. If configuring GL860, GL260, GL240, GL840 and GLT400 to connect to a wireless LAN	26
6. GL-Config	27
6-1. Launching and Terminating GL-Config	27
6-1-1. Launching	27
6-1-2. Terminating.....	27
6-2. Changing the Display Language.....	28
6-3. How to Change the USB ID	28
6-4. How to Configure LAN-related Settings	29
6-5. Device Initialization	30
6-6. How to Launch the USB Drive Mode	31
6-7. How to Change the Drive in USB Drive Mode	32
6-8. How to Update the Firmware Version	33
6-8-1. Precautions when Performing Version Updates	33

6-8-2. Version Update Procedure	33
7. GL-Connection	35
7-1. Basic Operation.....	35
7-2. Managing the Main Module.....	35
7-3. PC and Main Module Recording	35
7-3-1. PC Recording.....	35
7-3-2. Main Module Recording.....	36
7-4. Recorded Data Playback	36
8. Launching and Terminating GL-Connection Software.....	37
8-1. Launching the Software	37
8-2. Terminating the Software.....	37
9. Application Screen	38
9-1. Configuring the Application Screen.....	38
9-2. Base Window	38
9-2-1. Window Operations	38
9-2-2. Help Window.....	38
9-2-3. Control Panel	39
9-2-4. Window Expansion/Reduction Area	40
9-3. Connection Window	40
9-4. Main Window	40
10. Connection Screen	41
10-1. Connectable GL modules and limitations	41
10-2. Automatic Device Recognition	42
10-3. Connection Screen Explanation.....	43
10-3-1. PC Icon	43
10-3-2. GL Device Icon	43
10-3-3. PC File Icon	44
10-3-4. Recycle Bin Icon	44
10-4. Connection and Disconnection	45
10-4-1. Manual connection mode and automatic connection mode (Ver. 1.70 or later)	45
10-4-2. Manual connection mode.....	46
10-4-3. Automatic connection mode	47
10-4-4. Device Colors and Device Numbers	47
10-4-5. Disconnection and Deletion	47
10-4-6. Linked Connections (Synchronous and Multi-instrument Connections)	48
10-5. Saving and loading of device status (Ver. 1.70 or later)	51
10-5-1. Saved details	51
10-5-2. Notes regarding the device setting items.....	51
10-5-3. Saving and loading settings	51
10-6. Export logs (Ver. 2.60 or later).....	53

10-6-1. Communication Log Confirmation Dialog	53
10-7. Control Panel for the Connection Screen	55
10-7-1. Switch Screen	55
10-7-2. Search GL Devices	55
10-7-3. LAN connection	55
10-7-4. Connection Settings.....	55
10-7-5. Load Settings File	56
10-7-6. Option Settings	56
11. Main Screen.....	59
11-1. Tabs	61
11-1-1. Tab Elements and Status	61
11-1-2. Tab Icon Types	61
11-2. Status.....	62
11-3. Window Button.....	63
11-3-1. Child Window On / Off	63
11-3-2. Tab operation.....	63
11-3-3. Miximize	64
11-3-4. Close Tab.....	64
11-3-5. Maximizing and Closing a Child Window	64
11-4. Waveform Window.....	64
11-4-1. Switch wave mode	65
11-4-2. Y-T Waveform Display	65
11-4-3. X-Y Waveform Display.....	65
11-4-4. FFT Waveform Display	66
11-5. Time Line Window	67
11-6. Monitor Window	67
11-6-1. Digital Display	67
11-6-2. Statistical Calculation Display	67
11-6-3. Expanded Digital Display	68
11-7. Alarm Output Window	69
11-8. Recording Information Window.....	70
11-8-1. Free-running in Progress	70
11-8-2. Recording	70
11-8-3. Review	71
11-9. Cursor Information Window	72
11-10. Image window (Ver. 2.40 and later)	73
11-11. Other Windows	74
11-11-1. Navigation Window	74
11-12. Main Screen Control Panel.....	77
11-12-1. Main Panel.....	77
11-12-2. Condition.....	78

11-12-3. File	78
11-12-4. Save.....	84
11-12-5. Action.....	92
11-12-6. Option	92
11-12-7. Recording Start/Stop	93
11-12-8. Conversion saving start/conversion saving stop.....	93
12. Y-T Waveform Mode	94
12-1. Waveform Window.....	94
12-1-1. Waveform operation button	95
12-1-2. Cursor Operation button	98
12-1-3. Scale Display	103
12-1-4. Level bar display	105
12-1-5. Time Scale Display Contents.....	107
12-1-6. Cursor Display	107
12-1-7. Mark Display	107
12-1-8. Scroll Bar Horizontal	107
12-1-9. Scroll Bar Vertical	107
12-1-10. Switch Time Display.....	107
12-2. Time Line Window	108
12-3. Monitor Window	109
12-3-1. Digital Display	109
12-3-2. Statistics calculation display	112
12-3-3. Expanding Digital Display	113
12-4. Y-T Waveform Control Panel.....	114
12-4-1. Main Panel.....	114
12-4-2. Action.....	114
13. X-Y Waveform Mode	116
13-1. Waveform Window.....	116
13-2. Time Line Window	120
13-3. Monitor Window	121
13-3-1. Digital	121
13-3-2. Statistics calculation	122
13-4. X-Y Waveform Control Panel.....	124
13-4-1. Main Panel.....	124
13-4-2. Action.....	124
14. FFT Waveform Mode.....	125
14-1. Waveform Window.....	125
14-1-1. Waveform Operation.....	126
14-1-2. Cursor Operation	127
14-1-3. FFT Waveform.....	127

14-1-4. Peak Point	128
14-1-5. Zoom Navigator	128
14-1-6. Operations in Waveform Window	129
14-2. Timeline Window.....	131
14-2-1. Operations in Timeline Window	131
14-3. Monitor Window	132
14-3-1. Digital Display	132
14-3-2. Statistics Calculation Display.....	133
15. Device Settings	134
15-1. Main Settings	134
15-2. Amplifier Module Settings	135
15-2-1. Amplifier Module Settings Screen	135
15-2-2. Amplifier Setting tab: Voltage, Voltage/temperature, High-speed Voltage, High-voltage Modules, GL860, GL260, GL840, GL240, GL980, GL2000 and GLT400	136
15-2-3. Amplifier Setting tab: DC Strain Module	140
15-2-4. Amplifier Setting tab: Charge Module	147
15-2-5. Amplifier Setting tab: Logic/Pulse Module	151
15-2-6. Amplifier Setting tab: Voltage Output Module.....	152
15-2-7. Amplifier Setting tab: GL860, GL260, GL240, GL840, GLT400, each digital sensor / Wireless sensor / Remote terminal.....	156
15-2-8. Trigger-start/stop Setting Tab	159
15-2-9. Alarm Setting Tab	161
15-3. Amplifier Batch Display	163
15-4. Data Settings	164
15-4-1. Sampling Limits.....	169
15-5. Trigger Settings.....	171
15-5-1. GL7000, GL980, GL2000, GL860, GL260, GL240, GL840 and GLT400	171
15-6. Alarm Settings.....	173
15-6-1. Alarm Clear Button	173
15-7. Marker Settings.....	174
15-7-1. Display user mark during recording	174
15-8. Option Settings	175
15-9. Excel Settings	176
15-10. X-Y Settings	177
15-11. FFT Settings	178
15-11-1. Analyzing Function	179
15-11-2. Time Window	180
15-11-3. Average Mode and Average Count	181
15-12. Mail Settings	184
15-13. I/F Setting.....	186
16. Other functions	187

16-1. Data Compressing Function	187
16-2. Group functions.....	189
16-2-1. Types of group functions	189
16-2-2. Method of group creation	189
16-2-3. Example of Group use	191
16-3. Inter-CH calculation function (Ver.2.00 or later).....	192
16-3-1. Types of inter-CH calculation.....	192
16-3-2. Operation Procedures.....	192
16-3-3. Restore status.....	196
16-3-4. Save data file	197
16-4. Remote lock release function (Ver.2.00 or later)	198
16-4-1. Applicable models.....	198
16-5. Dual samplign function (Ver.2.20 or later)	201
16-5-1. Dual sampling function setting conditions.....	201
16-5-2. Dual sampling data recording	203
16-5-3. Dual sampling data playback	204
16-6. Image display function (Ver. 2.40 and later)	207
16-6-1. Configuring the image display function.....	207
16-6-2. About the image file timestamp information.....	208
16-6-3. Referenced location of log data files and image files	208
16-6-4. Displaying the image window	209
16-6-5. Synchronizing log data and image files	210

1. PREFACE

1-1. Usage Notes

1. Copying or transferring any or all of the contents of this document is prohibited.
2. The contents of this manual and the specification of the product are subject to change without notice.
3. Every effort has been made to ensure the quality and reliability of this document and product, but should you find unclear points or errors, please contact GRAPHTEC IWATSU Test Instruments.
4. GRAPHTEC IWATSU Test Instruments will not be held responsible for the effects caused as a result of using this document or product, regardless of the statement 3.
5. The performance of this product may not be satisfied depending on the operating environment. If this occurs, review your operating environment.

1-2. Trademarks

- * Microsoft and Windows are registered trademarks or trademarks of Microsoft Corporation in the United States and/or other countries.
- * .NET Framework is a registered trademark or trademark of Microsoft Corporation in the United States and/or other countries.
- * Other company names, logos, product names, and the like are trademarks or registered trademarks of their respective companies.

1-3. Copyright

GRAPHTEC IWATSU Test Instruments Co.,Ltd. owns the entire copyright to this instruction manual.

1-4. Usage procedure

This is the user's manual for the GL-Connection application software and the GL7000 management software, GL-Config. Set up the software according to the following procedures depending on the application environment.

- For customers who will not use the GL7000 Display Module
Step 1: Install the USB driver from the CD-ROM (if using a USB connection)
Step 2: Configure the LAN and USB ID settings in GL-Config.
Step 3: Install and open GL-Connection.
- For customers who will use the GL7000 Display Module and GL-Connection
Step 1: Install the USB driver from the CD-ROM (if using a USB connection)
Step 2: Configure the LAN and USB ID settings on the GL7000.
Step 3: Install and open GL-Connection.
- For customers who will use the GL7000 Display Module and will not use GL-Connection
Step 1: There is no need to install GL-Config and GL-Connection.
- For customers who will use GL980, GL2000, GL240 and GL840
Step 1: Install the USB driver from the CD-ROM (if using a USB connection)
Step 2: Configure the LAN and USB ID settings on the device.
Step 3: Install and open GL-Connection.

- For customers who will use GLT400

Step 1: Refer to the Quick Start Guide and install the USB driver from the internal memory with the USB drive mode function. (When using a USB connection).

Step 2: In the same way, install “GLT400 Setting App” and this software “GL-Connection”.

Step 3: Set the USB ID and LAN using “GLT400 Setting App”.

Step 4: Use GL-Connection with USB connection or LAN connection.

- For customers who will use GL260 and GL860

Step 1: Refer to the Quick Start Guide and install the USB driver from the main unit’s memory using the USB drive mode function. (When using a USB connection).

Step 2: Set the USB ID and LAN settings on the main unit.

Step 3: Install and use GL-Connection.

1-5. About GL-Config

The GL-Config application software is a software for GL7000 that manages by connecting the GL7000 to a PC.

This software is necessary for configuring transmission settings for the GL7000, especially when the GL7000 Display Module is not used.

(*The GL-Config is available for the GL7000 only. It cannot be used for other modules.)

The main features of GL-Config are as follows. (* A USB connection is required for all features other than firmware version upgrades)

- 1) USB ID settings and reference
- 2) LAN settings and reference
- 3) Version reference
- 4) Device formats (Internal flash, SD card, and SSD module)
- 5) USB drive mode device changes
- 6) Firmware version upgrades

1-6. About GL-Connection

The GL-Connection application software is software used to perform USB and LAN connections with the GL, to configure GL settings, and to carry out data recording, data playback and real-time display of input signals. The main functions of GL-Connection are as follows.

- 1) Multiple module connections to the GL device: Connect up to 20 modules mixing USB and LAN connections.
- 2) Automatic recognition of the GL device: Automatically recognizes a GL connected to a PC and displays a device icon. Connections are possible with one click.
- 3) Waveform and digital displays: There are diverse display options including digital values, and Y-T and X-Y displays.
- 4) Multi-screen functionality: Displays different waveforms on up to 4 screens.
- 5) Data recording function: Records in realtime on the PC with sampling of up to 1 ms in GBD (binary) or CSV (text) formats. Recording is possible (*There are limits to the sampling according to conditions)
- 6) Data playback function: Plays back recorded GBD (binary) and CSV (text) formatted files. Data recorded on the PC using this software can be played back at high-speed due to data compression.
- 7) Statistical calculation function: Displays the maximum value, minimum value, average value, peak value and the root mean squared value (*for playback data only) for both real-time and playback data.
- 8) Group function: A useful function that multilaterally displays the signal and playback data for one device.

- 9) E-mail notification function: A function that sends mail to a specified address when an alarm occurs due to the alarm function.
- 10) Direct Excel function: A function that transfers recorded data directly to Excel. Template file path creates a data file with a free format using a template file.
- 11) Synchronization and Multi-Instrument connection functions: Records data using sync cables between multiple GL7000 units. Also starts recording for multiple instruments even if the device doesn't support the sync cable. When stopping recording in a synchronous and multi-instrument connection connection state, data can be bound on the same time axis (for Ver.1.60 and after).(*Multi-instrument recording may not be synchronized)
- 12) Settings saving and loading functions: The connection status of devices and parameters for various settings can be saved and loaded as a settings file. When a file is loaded, the settings of the connected device will also be restored. (Ver. 1.70 or later)

2. Operation Environment for GL-Config and GL-Connection

Install the software on a PC that meets the following requirements.

Item	Necessary Conditions
OS	Windows 11 (64-Bit) *Meet system requirements of the OS * Operating systems that the OS manufacturer no longer supports are also not supported by GRAPHTEC IWATSU Test Instruments.
CPU	Intel Core 2 Duo or higher is recommended
Memory	4GB or higher is recommended
HDD	32GB of empty hard drive space is needed to install the software.
Display	Display 800x600 resolution or above, 65,535 colors or more (16-bit or above)
Others	USB port, an Ethernet port and a CD-ROM drive (when installing from CD) are necessary. Microsoft Excel (For using the Direct Excel function) * EXCEL2003 or later

* CHECKPOINT

* There are occasions when recording cannot be performed normally due to recording settings or the condition of the PC (such as if another application is running or if there is not enough free space for the recording medium) even if the PC in use has met the operating environment requirements for measured data recording. Close all other applications and record data on an internal hard disk when recording data.

* Depending on how to use (for example, to create multiple tabs), more conditions than the recommended environment may be required.

* Do not launch any other applications when using other companies software. Also do not execute processes or operations other than this software as much as possible. (Ex: screen savers, virus scanners, file copying or moving processes, file search processes, etc.)

3. Installing the USB Driver

Installing the USB driver is necessary if connecting GL-Config and/or GL-Connection using USB. USB driver installation will begin when selecting the automatic “USB driver installation” program on the attached CD-ROM.

Launch MultiSetup.exe on the CD-ROM if the program doesn’t launch automatically. For details, refer to the “Read the USB driver installation instructions” in the user’s manual.

For models other than GL7000, follow the instructions on the respective CD-ROM or in the main unit memory.



4. Installing GL-Config and GL-Connection

GL-Config and GL-Connection are installed together. One cannot be installed independently. The GL-Connection installer will launch and the installation will begin when selecting the automatic “GL-Connection Installation” program on the attached CD-ROM. Launch MultiSetup.exe on the CD-ROM if the program doesn’t launch automatically. Continue following the instructions from the installer from this point on.



* Caution

Be careful of the following points when connecting a GL device to a PC.

- Install using an administrator level account.
 - Do not connect anything other than the mouse and the keyboard to the PC's USB connection terminals.
 - Set the PC's energy saving function to Off.
 - Set the screen saver to Off.
 - Set the PC so that it does not go to sleep.
 - Notebook PCs may go into stand-by mode when the LCD (screen) is closed, so be sure that it doesn't go into stand-by mode when the LCD is closed when using this software.
 - Set virus and security software's automatic update function, and Windows' automatic update functions to Off.
-

5. How to Connect to a PC

5-1. Connecting using USB

This explains how to connect using a USB cable.

- GL7000

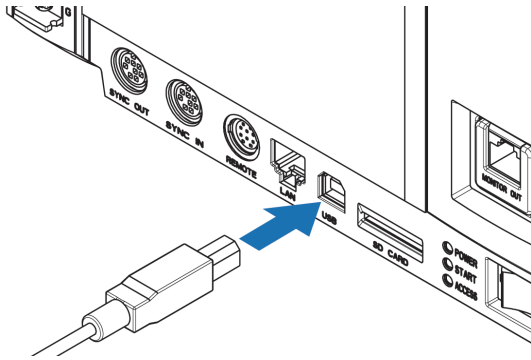

- GL260

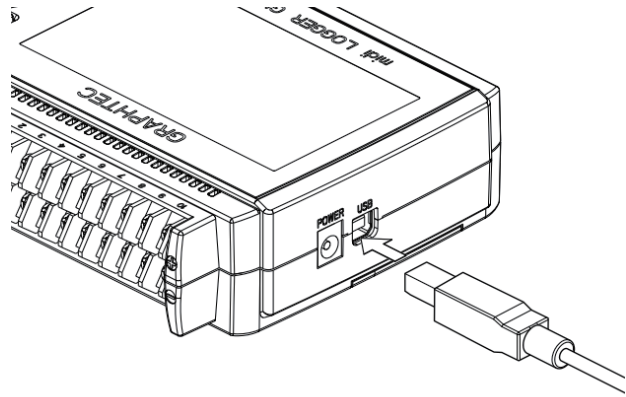

- GL860/GL840

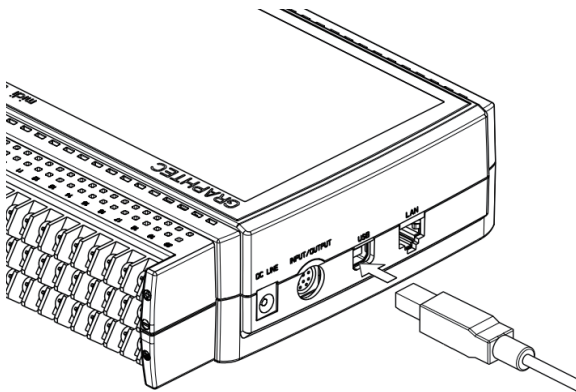

- GL240

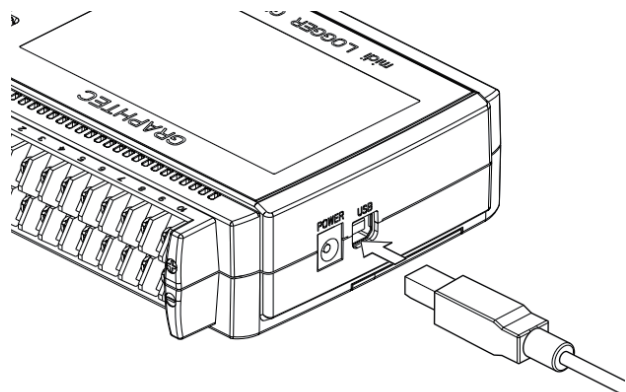

- GL980/GL2000

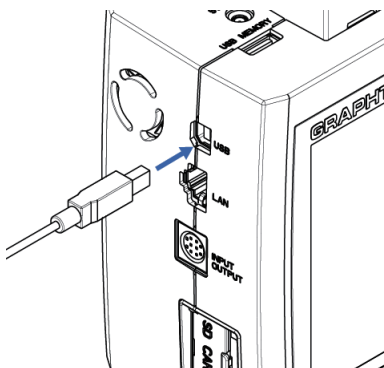

- GLT400

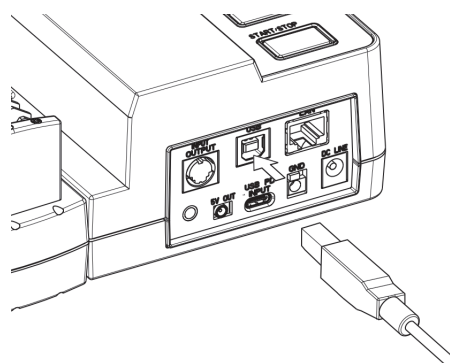

* CHECKPOINT

- Installing the USB driver on the PC is necessary when using a USB cable to connect. Refer to the "USB driver installation instructions" regarding the installation methods.
- Be sure not to mistakenly insert the USB cable into the wrong terminal since it is adjacent to the LAN connector.

Use an A-B-type cable when connecting the device to the PC.

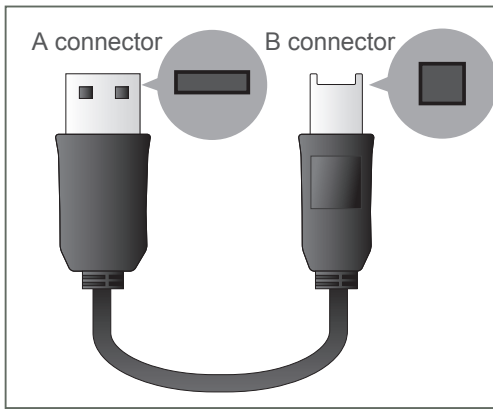

5-2. Connecting using a LAN

This explains how to connect using a LAN cable.

- GL7000

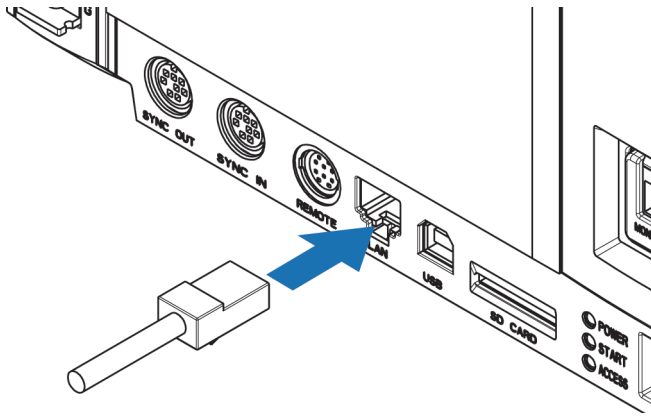

- GL860/GL840

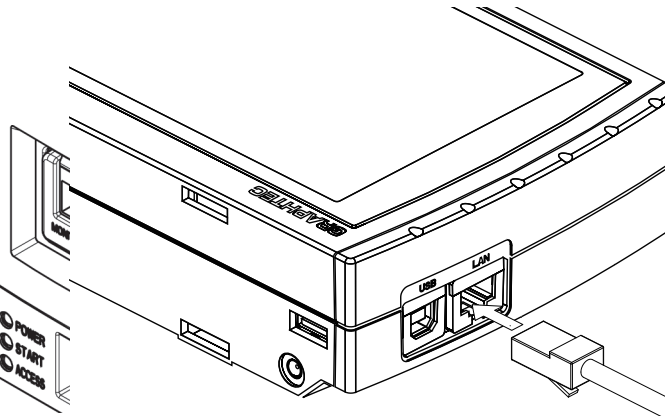

- GL980/GL2000

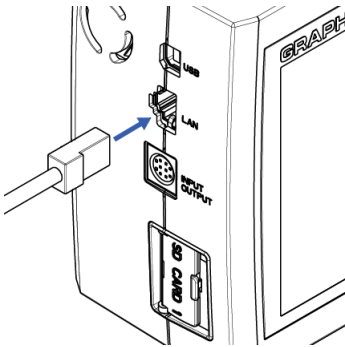

- GLT400

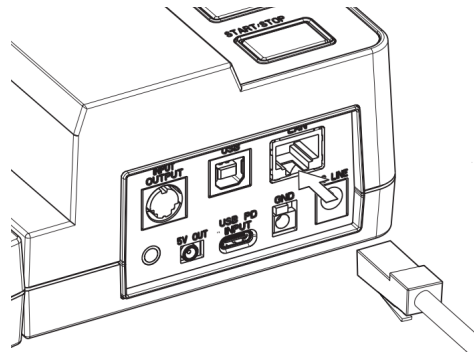

Use the following type of LAN cables depending on the usage context.

- Types of LAN cables

Use a cross over cable if connecting directly to the PC without the use of a hub.



Use a straight cable if using a hub to connect to a PC.

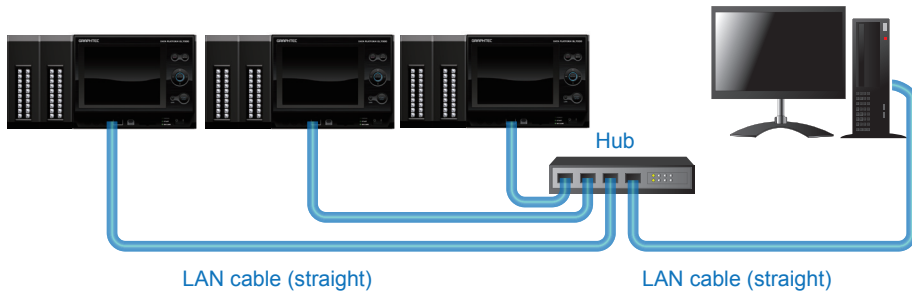

* Use a LAN cable of Category 5 (Cat5) type or later.

5-3. Setting the USB ID or the IP Address

Configure the GL device's I/F settings in order to connect it to the PC.

5-3-1. When setting the GL7000 with the GL-Config

You can configure the LAN settings and USB settings using the GL-Config software packaged with GL-Connection. Please refer to 6. GL-Config

5-3-2. When setting the GL7000 with the display module

Configures LAN and USB settings using the Display Module options.

• USBSettings

Set the USB ID. It can be set between 0 and 9. Assign separate numbers for each GL device so that the USB IDs do not overlap when connecting multiple GL devices with USB.

1. Click [Home] on the bottom-right corner of the screen or press the [Home] key from the launch screen.
2. Click [Main Module] on the screen.
3. Click [I/F USB Settings] on the screen.
4. Set the number by clicking the [USB ID] number section.

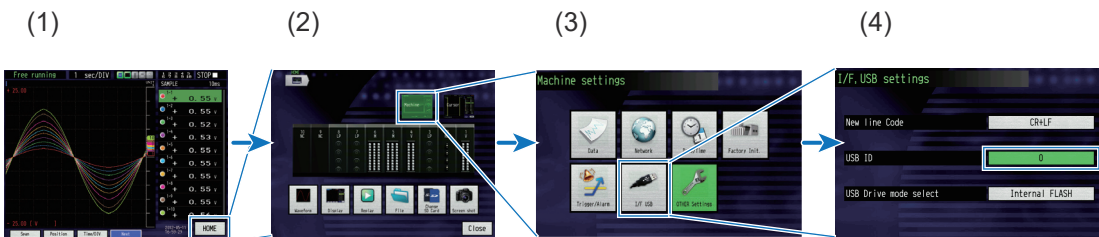

• LAN Settings

1. Click [Home] on the bottom-right corner of the screen or press the [Home] key from the launch screen.
2. Click [Main Module] on the screen.
3. Click [Network Settings] on the screen.
4. Change each of the network settings.

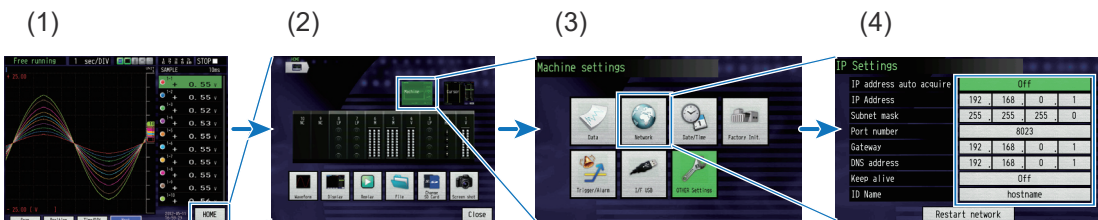

Configure the LAN settings to match the network environment for each PC in use. Refer to the main module user's manual on CD-ROM for a detailed explanation of the LAN setting parameters.

* The IP address can be acquired automatically if a DHCP server is being used in the identical network segment and if it uses automatic IP address acquisition.

5-3-3. When setting the USB connection to the GL860, GL260, GL980, GL2000, GL240 or GL840

- **GL860**

Press the MENU key five times to open "I/F Settings". Input the "USB ID".

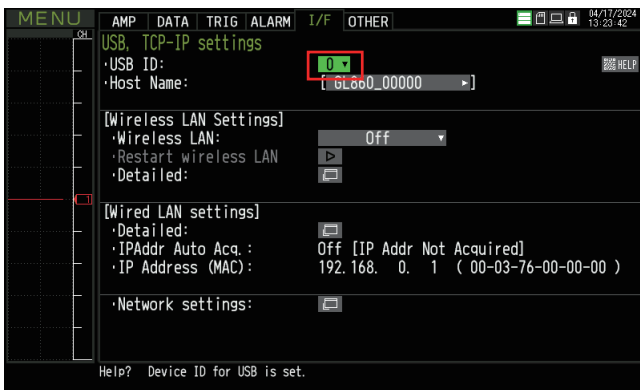

- **GL260**

Press the MENU key five times to open "I/F Settings". Input the "USB ID".

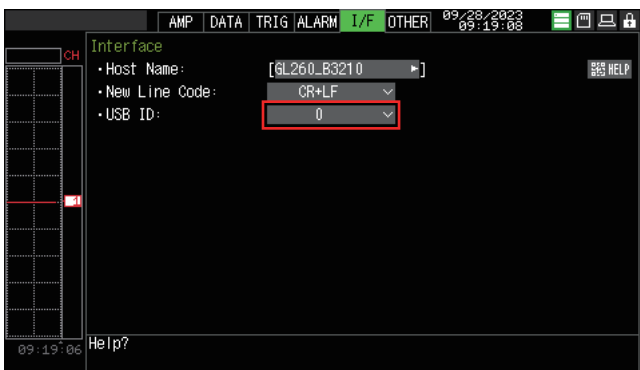

- **GL980/GL2000**

Press the MENU key five times to open "I/F". Input the "USB ID".



- **GL240**

Press the MENU key four times to open "OTHR Settings". Input the "USB ID".

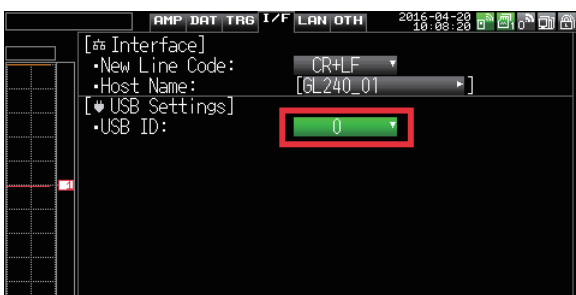

- **GL840**

Press the MENU key four times to open "OTHR Settings". Input the "USB ID".

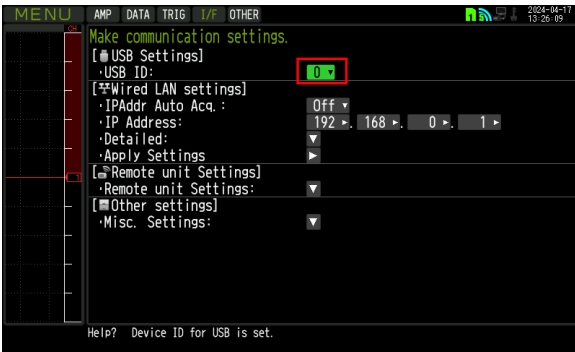

* CHECK POINT

After changing the USB ID setting of this unit, turn off and on the power of this unit.

5-3-4. When setting the USB connection to the GLT400

The initial value of GLT400 USB ID is "0", so connect with USB ID 0 for the first connection.

Start GLT400 Setting App and connect with USB ID 0.

Press the "Settings" button to open the settings screen.

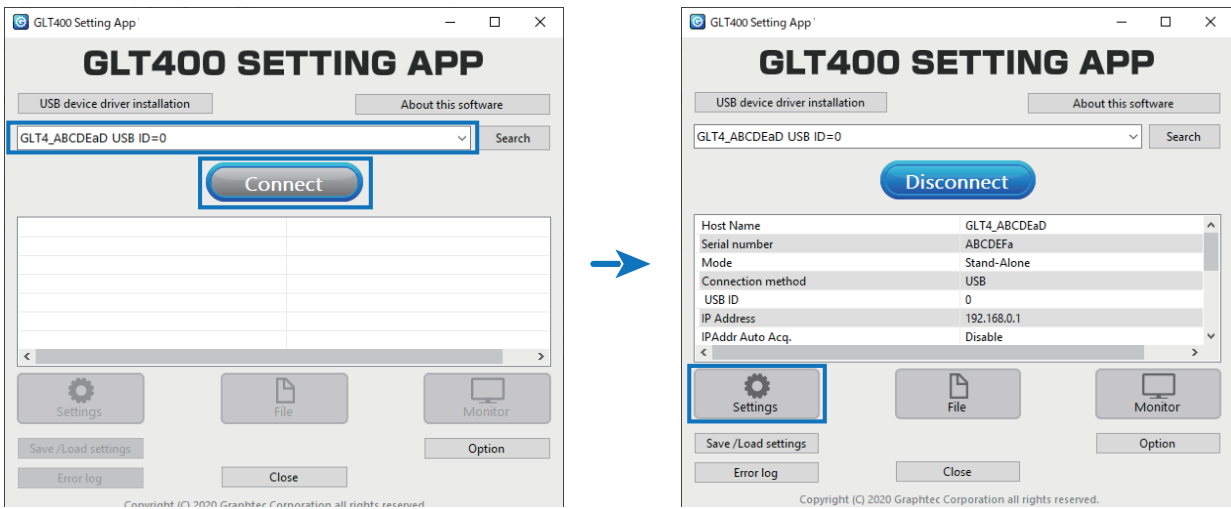

Press the "I/F" tab to switch to the I/F screen.

Set an arbitrary USB ID and close it.

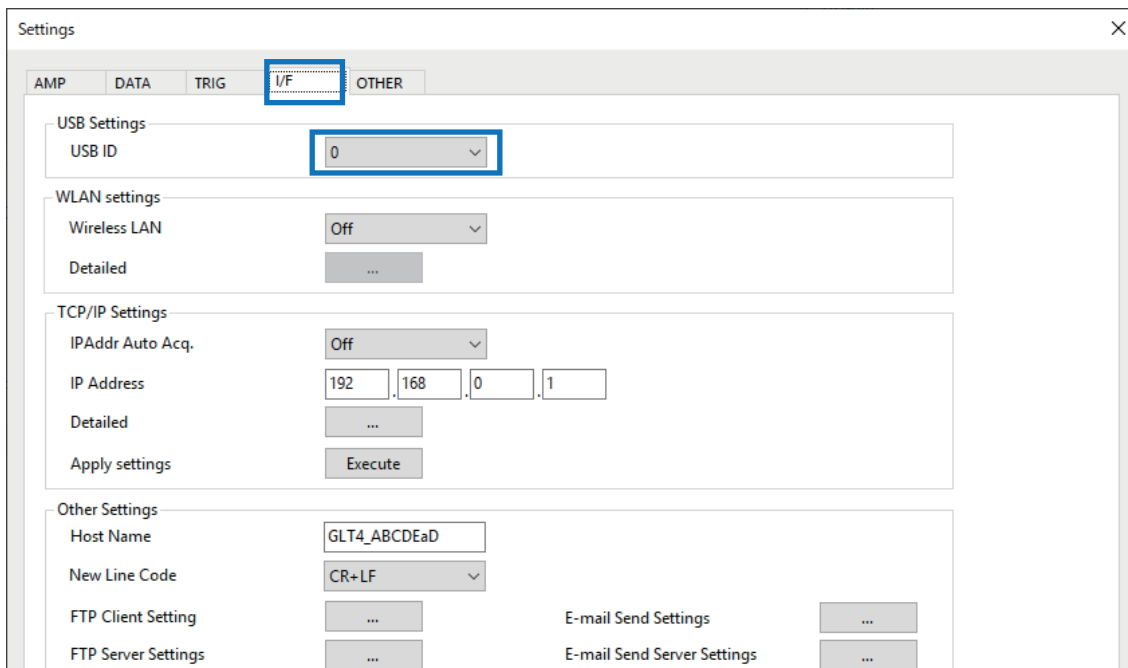

5-3-5. When setting the LAN connection to the GL980, GL2000

Press the [MENU] key five times to open the [I/F] menu.

Set the [IP Address], [Subnet Mask], [Port Number], [DNS Address] and select [Reflect Settings] to accept the changes.

- Using Auto IP Address Acquisition

If there is a DHCP server in the same segment of the connected network, Auto IP Address Acquisition is available.

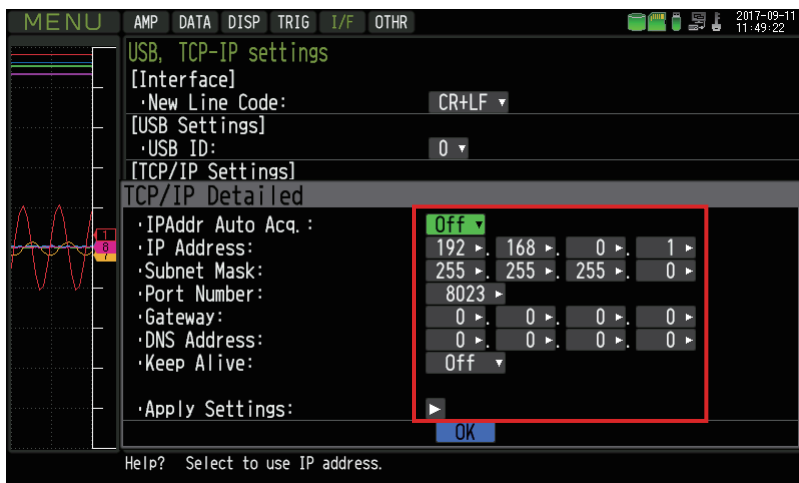

5-3-6. When setting the LAN connection to the GL840

Press the [MENU] key four times to open the [I/F] menu.

Set the [IP Address], [Subnet Mask], [Port Number], [DNS Address] and select [Apply Settings] to accept the changes.

- Using Auto IP Address Acquisition

If there is a DHCP server in the same segment of the connected network, Auto IP Address Acquisition is available.

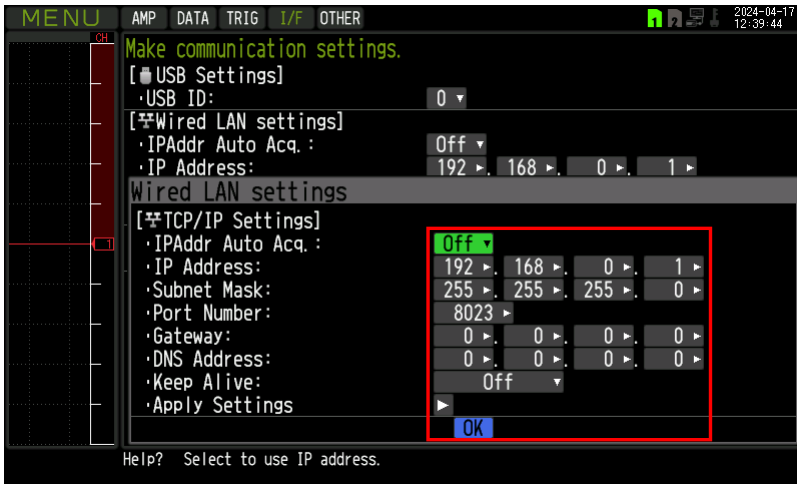

5-3-7. When setting the LAN connection to the GL860

Press the [MENU] key five times to open the [I/F] menu.

Set the [IP Address], [Subnet Mask], [Port Number], [DNS Address] and select [Apply Settings] to accept the changes.

- Using Auto IP Address Acquisition

If there is a DHCP server in the same segment of the connected network, Auto IP Address Acquisition is available.

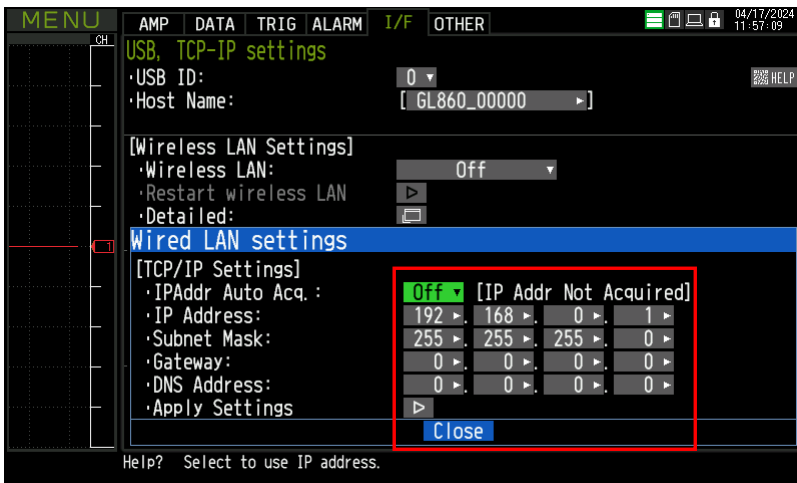

5-3-8. When setting the LAN connection to the GLT400

The IP address of GLT400 is "192.168.0.1". To change it, use a USB connection.

Start GLT400 Setting App and connect with USB.

Press the "Settings" button to open the settings screen.

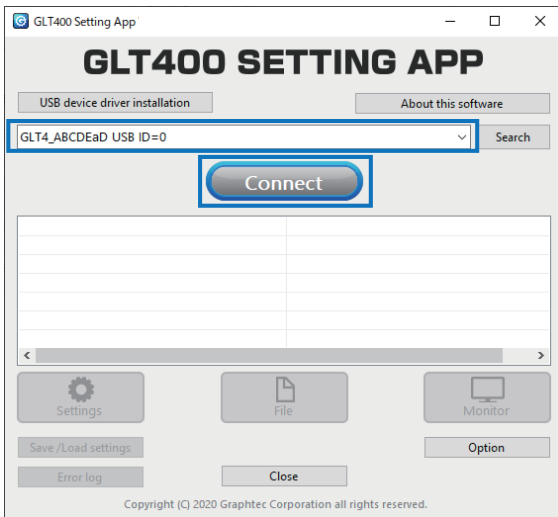

Press the "I/F" tab to switch to the I/F screen.

After setting TCP/IP, execute "Apply settings". For detailed settings, open the detailed setting screen, and after executing the setting, execute "Apply settings".

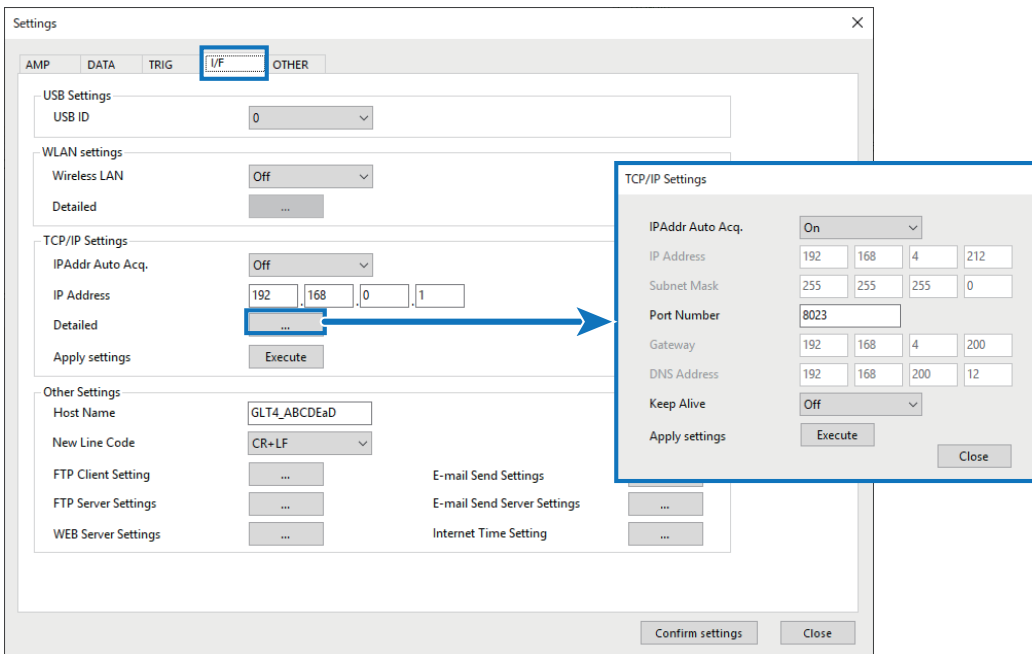

5-3-9. PC TCP-IP Settings

Refer to the following settings when connecting one PC to one GL device (when not connecting to a network such as an internal company LAN). Connect the GL device to the PC using a crossover cable.

PC IP address	192.168.1.1
GL device IP address	192.168.1.2

* CHECKPOINT

Set the subnet mask normally in this case to "255.255.255.0".

Set the port number normally in this case to "8023".

[Control Panel]→[Network and Sharing Center]→[Local Area Connections]→[Status Window]→[Properties]→[Internet Protocol (TCP/IP)]→[Properties]→Check "Use the following IP address" →Set the [IP Address] and [Subnet Mask] fields→[OK]

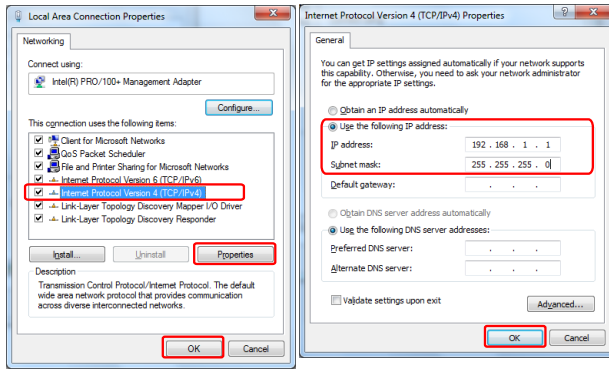

5-3-10. **If configuring GL860, GL260, GL240, GL840 and GLT400 to connect to a wireless LAN**

The wireless LAN function is available only if the wireless LAN option for the GL860, GL260, GL240, GL840 and GLT400 models are implemented.

For details about how to set a wireless LAN for GL860, GL260, GL240, GL840 and GLT400 see the user manual of each device.

* CHECKPOINT

If you do not meet the set conditions, or to improve the communication environment, you will need to slow down the speed of the sampling interval.

If a wireless sensor is connected, connect to this software with the GL main device detecting the wireless sensor properly.

6. GL-Config

* The GL-Config is available for the GL7000 only. It cannot be used for other modules.

6-1. Launching and Terminating GL-Config

6-1-1. Launching

Launch the software by choosing "Start" on the OS taskbar → "Programs (All Programs)" → "Graphtec" → "GL-Connection" → "GL-Config". The following screen will display when it's finished launching.



6-1-2. Terminating

Click the [X] button on the title bar to terminate the program.

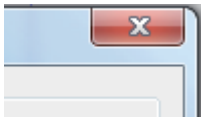

6-2. Changing the Display Language

Changes the display language for GL-Config to English or Japanese (the initial setting is English).

Step 1. Launch the software following instructions in “6-1. Launching and Terminating GL-Config”.

Step 2. Change the language by selecting Japanese or English from the “Language” menu.

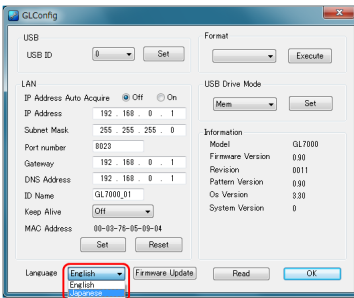

6-3. How to Change the USB ID

Set each GL7000 main module USB ID one at a time using GL-Config before launching GL-Connection when connecting using USB cables and USB hubs to connect multiple GL7000 main modules (up to 10 modules) to one PC.

Be sure not to overlap each GL7000 main module USB ID when doing this.

Step 1. Connect one GL7000 main module to the PC using a USB cable, and plug in the GL7000 main module's power source.

Step 2. Launch the software following instructions in “6-1. Launching and Terminating GL-Config”.

Step 3. Select “Read” to establish communication with the GL7000.

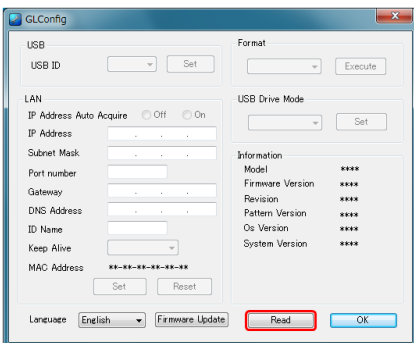

Step 4. The current GL7000's USB ID will be displayed, so change it to the appropriate value.

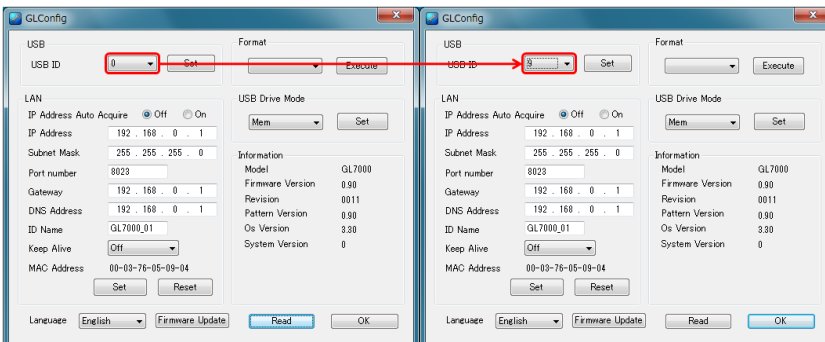

Step 5. Select “Set”, and apply settings to the GL7000.

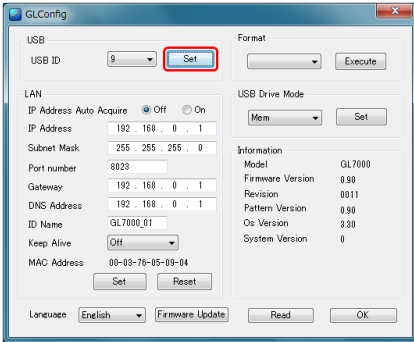

6-4. How to Configure LAN-related Settings

Step 1. Connect one GL7000 main module to the PC using a USB cable, and plug in the GL7000 main module’s power source.

Step 2. Launch the software following instructions in “6-1. Launching and Terminating GL-Config”.

Step 3. Select “Read” to establish communication with the GL7000.

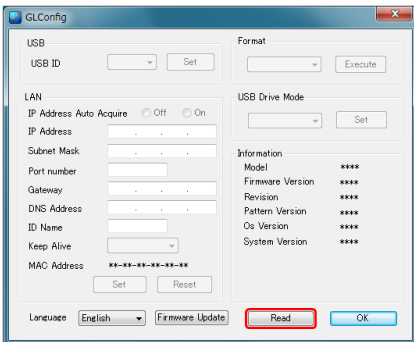

Step 4. The current GL7000’s LAN-related settings will be displayed, so configure the appropriate settings according to the network environment. Refer to the main module user’s manual on the CD for more details on each setting.

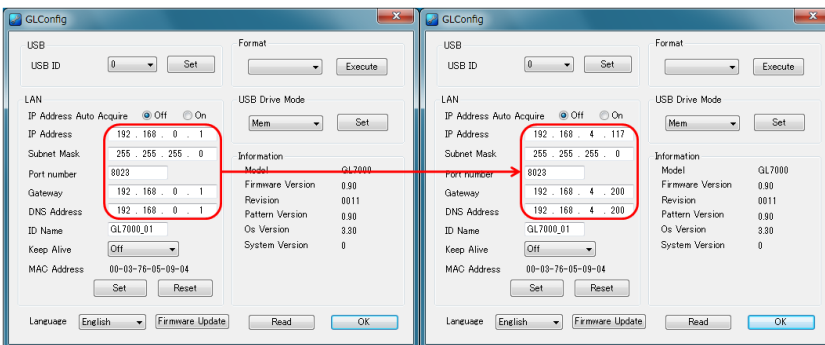

Step 5. Select “Set”, and apply the settings to the GL7000 main module.

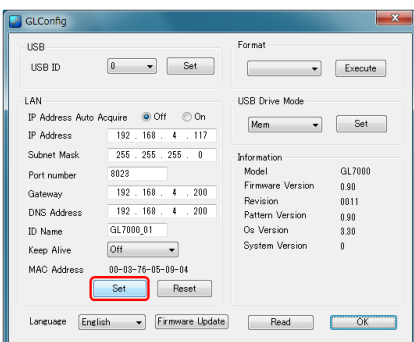

6-5. Device Initialization

Initialize the memory device (Internal flash memory/SD Card/SSD Module) that is connected to the GL7000 main module using GL-Config. Be aware that all of the data on the memory device will be deleted when initialized.

- Step 1. Connect one GL7000 main module to the PC using a USB cable, and plug in the GL7000 main module's power source.
- Step 2. Launch the software following instructions in “6-1. Launching and Terminating GL-Config”.
- Step 3. Select “Read” to establish communication with the GL7000.

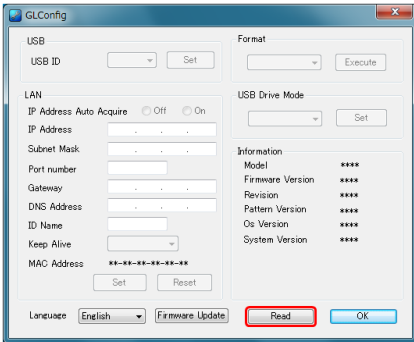

Step 4. Chose the memory device to be initialized from the initialization menu. (Internal flash memory/SD Card/SSD Module)

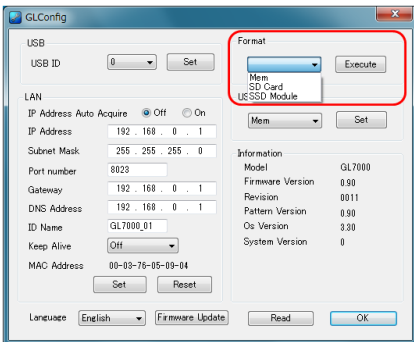

Step 5. Select “Execute” and then “OK” when the confirmation screen is displayed.

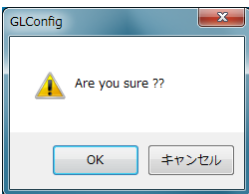

Step 6. Select “OK” when the completion screen is displayed.

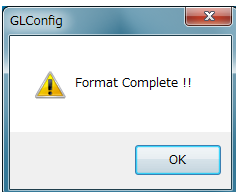

6-6. How to Launch the USB Drive Mode

The USB Drive Mode function recognizes a memory device (Internal flash memory/SD Card/SSD Module) compatible with the GL7000 main module as an external drive from the PC. This allows for simple transfers with the PC that feel the same as PC data of data saved on the memory device connected to the GL7000 main module.

Step 1. Remove the GL7000 main module's fixed screws (in two locations on the side of the module).

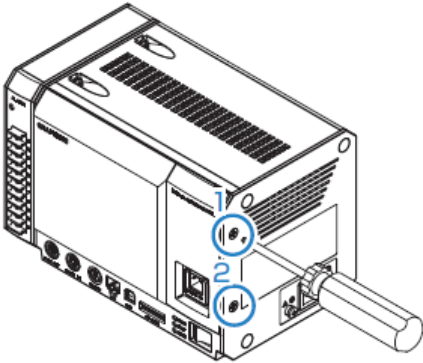

Step 2. Pull the upper right tab of the face cover forward, and remove the face cover.

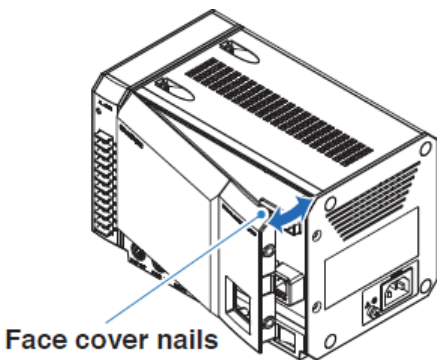

Step 3. Turn the DIP switch for the USB drive that is under the face cover to "ON".

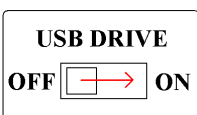

Step 4. Connect one GL7000 main module to the PC using a USB cable, and plug in the GL7000 main module's power source.

Step 5. The GL7000 main module will launch in USB Drive Mode, and will be recognized on the PC as an external drive.(It will launch using the main module's memory in its initial state)

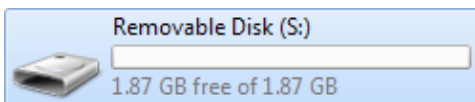

6-7. How to Change the Drive in USB Drive Mode

Select the memory device that will launch in USB Drive Mode from the devices connected to the GL7000 main module using GL-Config.

- Step 1. Connect one GL7000 main module to the PC using a USB cable, and plug in the GL7000 main module's power source.
- Step 2. Launch the software following instructions in "6-1. Launching and Terminating GL-Config".
- Step 3. Select "Read" to establish communication with the GL7000.

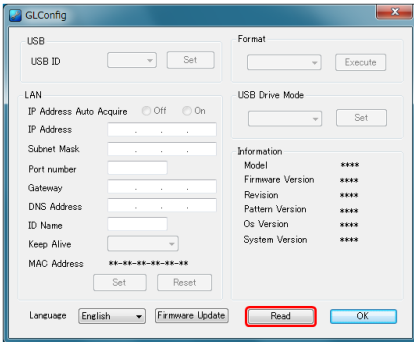

- Step 4. Choose the memory device to launch with from the USB Drive Mode menu. (Internal flash memory/SD Card/SSD Module)

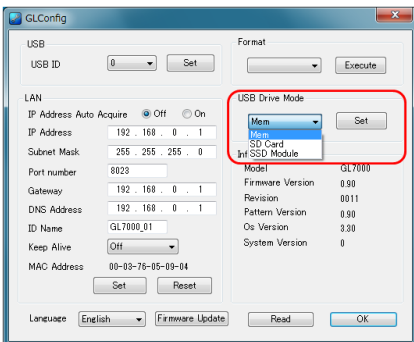

- Step 5. Select "Settings", and apply the settings to the GL7000 main module.

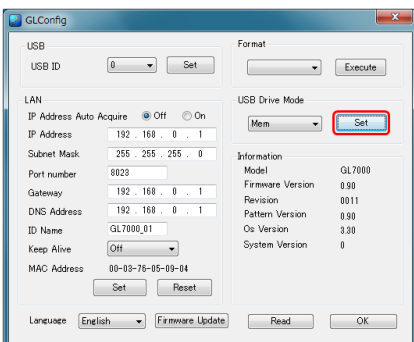

- Step 6. Remove the main module's power source, then remove the USB cable.
- Step 7. The settings will be applied the next time the main module launches. Refer to "6-6. How to Launch the USB Drive Mode" for the procedure for launching USB Drive Mode.

6-8. How to Update the Firmware Version

Update the GL7000 main module's firmware version using GL-Config.

6-8-1. Precautions when Performing Version Updates

* Update the version when the main module is at hand. If performed when isolated, such as through a network, it may cause a failure to update the version.

* Absolutely do not remove the power source during the version update. If the power source is removed during the operation, the main module's firmware will be destroyed, and it may be impossible to restore.

* The settings will be initialized when carrying out the version update. Save the setting parameters beforehand. Refer to Main Module Data in the GL-Connection manual for how to save the settings.

* The settings in the I/F menu (such as USB-ID, etc.) may change due to the version update. The I/F menu settings cannot be saved to a file. Make a note of the settings beforehand and reconfigure them after the version update.

6-8-2. Version Update Procedure

- Step 1. Download the latest GL7000 firmware from this company's website (<https://graph teciwatsu.com/en/>)
(*Please answer our simple questionnaire.)
- Step 2. Connect one GL7000 main module to the PC using a USB cable or a LAN cable, and plug in the GL7000 main module's power source.
- Step 3. Launch the software following instructions in "6-1. Launching and Terminating GL-Config".
- Step 4. Select "Read" to establish communication with the GL7000.
- Step 5. The "MainVerxxxRevyyyyAzz.GL7000" file will be created after extracting the downloaded "GL7000Vxxx.exe" by double clicking.

Name	Explanation
xxx: Version Information	100 → V1.00
yyyy: Revision Information	0001 → Rev001
zz: Special Item Number	00 → Reference Standard

- Step 6. Select "Firmware Update" and the firmware update screen will be displayed.

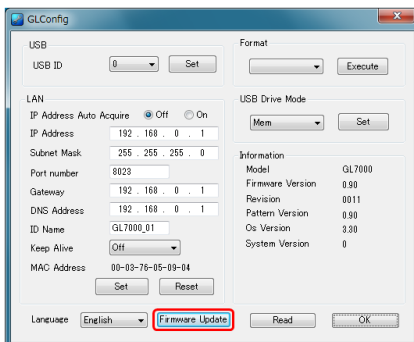

Step 7. Select “Browse” and select the extracted file from step 5.

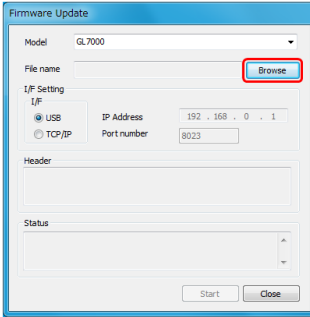

Step 8. Configure the I/F settings according to the type of cable connected.

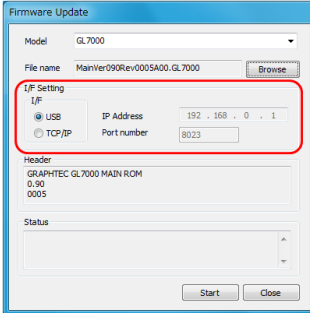

Step 9. Select “Start” to start the update. When the confirmation screen is displayed after the update is finished, select “OK”.

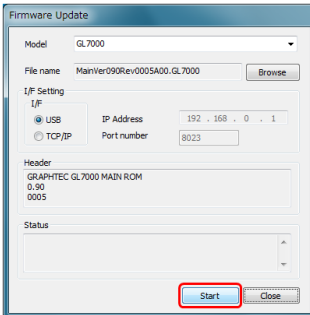

Step 10. A buzzer will ring when the update is completed if the GL7000 Display Module is equipped. When the update is complete, the SD Card LED will go from from flashing to solid, even if the Display Module is not equipped.

7. GL-Connection

7-1. Basic Operation

This software can be used with GL7000, GL860, GL260, GLT400, GL980, GL2000, GL240 and GL840.

The basic operation of the GL-Connection software consists of the following 4 configurations.

Description	Explanation
1. Managing the GL device (main module)	Manages the operations and settings for the main module, and loads the main module's setting information on to this software through the connection between the GL device and the PC.
2. Confirmation of the input data	Confirms the input signals to the main module in real-time using this software's graphical displays through the connection between the GL device and the PC.
3. Data Recording	Saves transmitted data to the PC through the connection between the GL device and the PC. And either the PC or the GL device can be used as a backup due to the ability to save recorded data on the main module.
4. Recorded data playback	Plays back recorded data files on the PC. Also plays back saved data on the main module through the connection between the GL device and the PC. Played back data may be split into important segments and converted to, then saved in other formats.

7-2. Managing the Main Module

This software allows the following management functions.

- Start/stop recording
- Amplifier settings (input, range, filter, etc.)
- Recording settings (sampling interval, main module recording destination, external sampling setting, etc.)
- Trigger and alarm settings (trigger level settings, alarm level settings, etc.)
- Other settings (temperature unit changes, factory settings, etc.)

7-3. PC and Main Module Recording

This software allows management of PC and main module recording. PC recording saves data received from the GL device on a file on the PC. Main module recording saves recordings performed on the main module on a recording medium. PC recording and main module recording can be performed simultaneously.

* Recording to the PC cannot be performed if the main module's recording destination is Internal RAM or the SSD Module (optional).

7-3-1. PC Recording

The recording capacity depends on the OS limits, but recordings can be over 2TB (terabytes) when using the general Windows 10/11 NTFS file system. PC recording can also be continuously performed even if the disk becomes full on the main module recording. PC recording creates separate Min/Max compression data with the recorded data. This data reduces the number of data reads during playback to improve operability. For information, refer to "P.16-1. Data Compressing Function".

7-3-2. Main Module Recording

The data is saved to the recording media in the GL7000. The recording destination depends on the GL module's hardware configuration. There are Internal RAM, Internal flash, external SD card, external USB memory, or 128GB extended SSD module (optional) as a recording destination.

- **GL7000**

- Internal RAM: Records from a maximum of 1 microsecond due to the equipped amplifier. PC recording cannot be performed simultaneously.
- Internal flash memory and SD Cards: Records from a maximum of 1 millisecond.
- SSD Module: Records from a maximum of 1 microsecond due to the equipped amplifier. PC recording cannot be performed simultaneously.

- **GL980, GL2000**

- Internal RAM: Records from a maximum of 1 microsecond due to the equipped amplifier. PC recording cannot be performed simultaneously.
- Internal flash memory USB memory and SD Cards: Records from a maximum of 1 millisecond.

- **GL260, GL240, GL840, GLT400**

- Internal flash memory and SD Cards: Possible to record from fastest 10ms/CH.

- **GL860**

- Internal flash memory and SD Cards: Possible to record from fastest 5ms/CH.

(*Refer to "15-4-1. Sampling Limits" for the sampling intervals that can be set.)

7-4. Recorded Data Playback

Data recorded as GBD (binary) data or CSV (text) data can be played back with this software. It is possible to confirm the played back data's signal level, and to display statistical values such as maximum value or minimum value, etc., for a specified range. There is also a conversion saving function, which splits and saves only important data segments, and a file connection function, which combines multiple connected data segments.

8. Launching and Terminating GL-Connection Software

8-1. Launching the Software

Launch the software by choosing “Start” on the OS taskbar→”Programs (All Programs)”→”Graphtec”→”GL-Connection”→”GL-Connection”. The following screen will display when it’s finished launching. (The following image is confirming two GL7000 modules.)



- * When the software does not launch
Try the following when the software does not launch.
<When it cannot launch initially>
Confirm whether the PC being used meets the operating requirements.
The installation may not have been performed correctly. Delete the program from the control panel and reinstall it.
- <When it cannot launch after the initial launch>
There may be competing settings files. Delete the following files and launch the software.
My Documents→ Graphtec → GL-Connection →Ini Delete everything in the Ini folder
My Documents→ Graphtec → GL-Connection → Data → Comp Delete everything in the Ini folder

8-2. Terminating the Software

Click the “X” on the upper right corner of the main screen to terminate the software.



A settings file is created when the software is terminated, but when the software is terminated using any method other than the previous one (i.e. forced termination, etc.), the settings file is not created.

9. Application Screen

9-1. Configuring the Application Screen

The following screen is this application's screen configuration.

- Base Window
- Connection Window
- Main Window

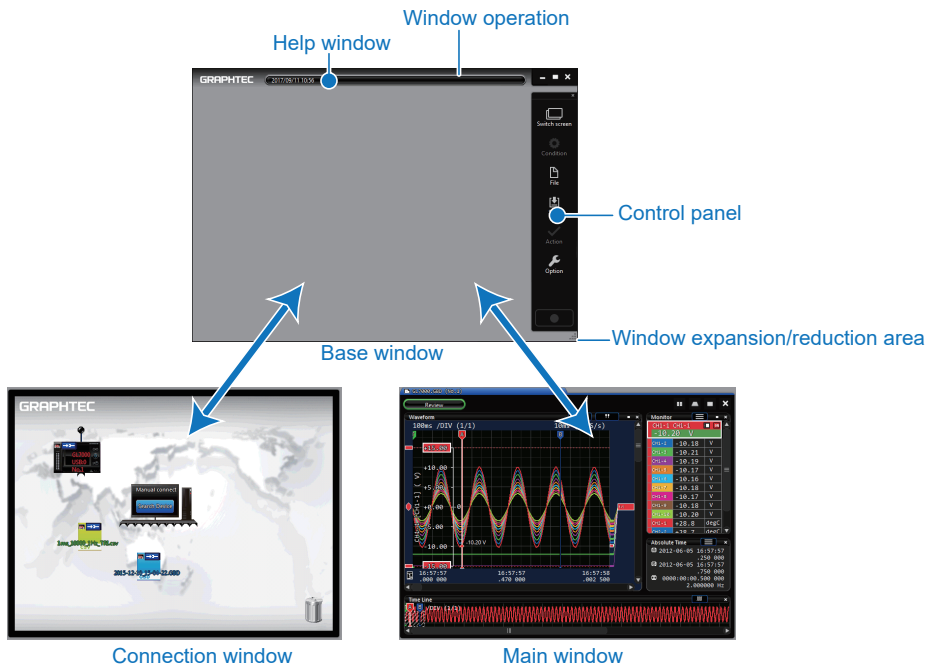

9-2. Base Window

This is the window that acts as a base that includes the connection window and the main window.

9-2-1. Window Operations



Minimize - Minimizes the application window.

Maximize - Maximizes the application window, and returns to the original size.

Close - Closes and terminates the application window.

9-2-2. Help Window



Displays help information for mouse buttons and so forth. The help window allows for efficient browsing of the help file whether scrolling through the numerous character data up, down, left or right.

9-2-3. Control Panel

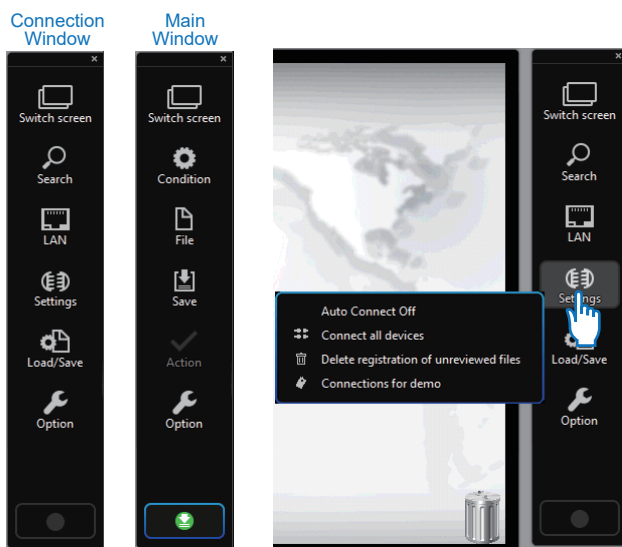

The window for performing operations on the connection window and the main window. The buttons on the control panel change dynamically for the connection window and the main window. The buttons on the control panel are divided into function groups and when a button is pressed, a related sub-panel will appear. Function items can be selected from the sub-panel.

- **Control Panel and Window Operations Lock**

It is possible to lock operations by closing the control panel. Press the lock from the control panel's option button, input a password and press the OK button to create a password lock. Repeat these operations and re-input the password to remove the lock.

Lock Status



Password Input Screen

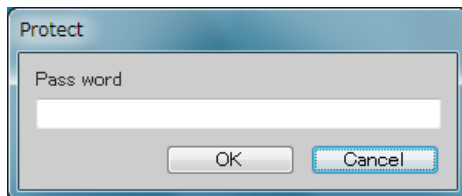

* Be sure not to forget the password when using a lock with a password.
The lock status doesn't support the forced termination of this application. The software will launch unlocked the next time it is launched.

9-2-4. Window Expansion/Reduction Area



Change the screen size by dragging the bottom right (window expansion/reduction area) of the base window. The minimum screen size is 800 x 600 dot. One screen section display is recommended at minimum size. When multi-windows are at their minimum size, they may display overlapped, and may not be forcefully displayed in the internal window. In that case, increase the screen size, or section it into one screen.

9-3. Connection Window

For more information about the Connection Window, refer to 10. Connection Screen

9-4. Main Window

For more information about the Main Window, refer to 11. Main Screen

10. Connection Screen

The GL-Connection can connect up to 20 modules at the same time, regardless of the GL module type and USB / LAN.

10-1. Connectable GL modules and limitations

perModule name	USB connection	LAN connection	Maximum number of modules or channels per one machine
GL7000	OK	OK	10 modules (112ch)
GL980	OK	OK	12ch (* Analog 8ch + Logic / Pulse 4ch)
GL2000	OK	OK	8ch (* Analog 4ch + Logic / Pulse 4ch)
GL240	OK	OK * If the optional wireless LAN unit (B-568) is installed	28ch (* Analog 10ch + wireless sensor (WL)10ch+main device logic/pulse 4ch + wireless sensor (WL) logic/pulse 4ch)
GL840	OK	OK (Wired/wireless) * In case of wireless, if the optional wireless LAN unit (B-568) is installed	288ch (* Analog 200ch+digital sensor (GS)10ch+ wireless sensor (WL)50ch+main device logic/pulse 4ch+digital sensor (GS) logic/pulse 4ch+ wireless sensor (WL) logic/pulse 20ch)
GLT400	OK	OK (Wired/wireless) * In case of wireless, if the optional wireless LAN unit (B-568) is installed	204ch (* Analog 200ch + logic/pulse 4ch)
GL260	OK	OK * If the optional wireless LAN unit (B-568) is installed	14ch (* Analog 10ch + logic/pulse 4ch) Calculation between CHs on the GL260 main unit is not supported.
GL860	OK	OK (Wired/wireless) * In case of wireless, if the optional wireless LAN unit (B-568) is installed	204ch (* Analog 200ch + logic/pulse 4ch) *CH-to-CH operation of the main unit is not supported

perModule name	Module or main module version	Compatible GL-Connection version
GL7000	Voltage, Volt./Temp, High-speed, Logic/Pulse module	Ver 1.00 or later
	High voltage module	Ver. 1.10 or later
	DC strain module	Ver.1.20 or later
	Charge module	Ver.1.30 or later
	Voltage output module *Single use of this unit can not	Ver.1.40 or later
GL240	Ver. 1.21 or later	Ver. 1.80 or later
GL840	Ver. 1.21 or later *Supports remote terminal (GLT400) Ver. 1.60 or later	Ver. 1.80 or later *Supports remote terminal (GLT400) Ver. 2.50 or later
GL980/GL2000	Ver. 1.00 or later	Ver. 2.00 or later
GLT400	Ver. 1.00 or later	Ver. 2.50 or later
GL260	Ver. 1.00 or later	Ver. 2.60 or later
GL860	Ver. 1.00 or later	Ver. 2.70 or later

10-2. Automatic Device Recognition

GL-Connection automatically searches for GL devices that are connected when the “Search” button is pressed and launching. The devices found through the automatic search will be displayed as a device icon on the screen. Click the displayed device icon to initiate the connection. Up to 30 icons including files and GL devices (up to 20 GL device icons) can be recognized.

(*When the limit of device and file icons has been reached, new icons won't be displayed, and connection or playback cannot be performed. In that case, delete icons to reduce their number.)

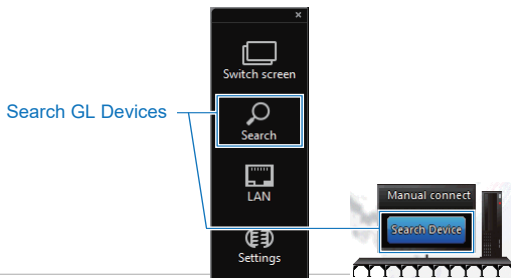

* Automatic recognition through LAN will only occur within the same network segment.

* Confirm the following and perform these operations when a device is not recognized.

- Confirm whether the GL device's interface cable is connected correctly.
- Confirm whether the GL device's power source is plugged in (or plug it in again).
- Confirm that the GL device's USB ID or IP address is not duplicated.
- Change to another number or address if it is duplicated.
- Confirm whether the devices can be automatically recognized using the LAN.
- Relaunch the application.
- Relaunch the PC.

10-3. Connection Screen Explanation

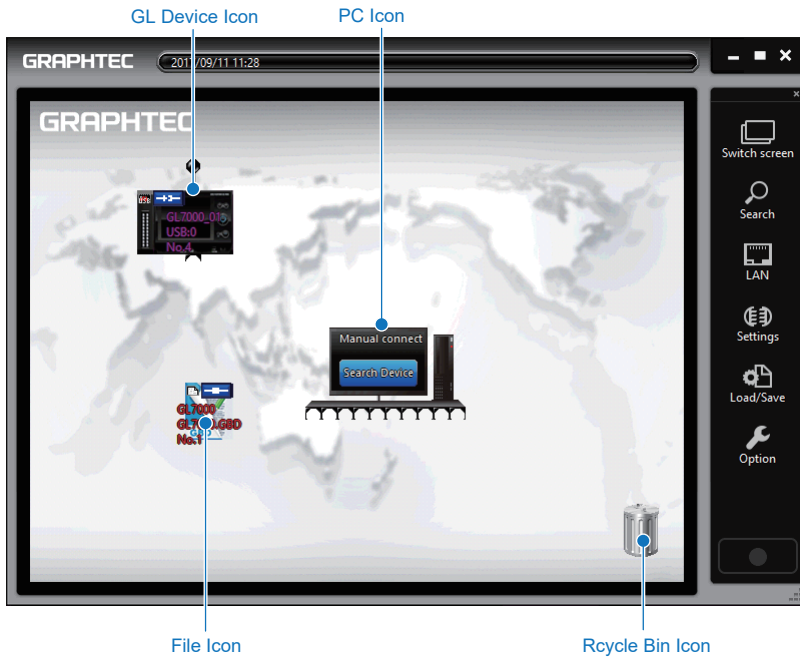

10-3-1. PC Icon



This icon indicates the PC being used. This can be moved to any position by using the mouse to drag the icon. Click on the button over the PC icon to perform an operation equivalent to Search Device. The content of the button will differ during automatic connection. Refer to 10-4-1. Manual connection mode and automatic connection mode (Ver. 1.70 or later) for details on automatic connection.

10-3-2. GL Device Icon



This icon indicates the GL device that has been recognized. This icon is displayed when a GL device is connected by USB or LAN and recognized. Start the connection by clicking on the button over the icon.

- **Types of GL Device Icon**

The following types of GL device icons will occur depending on the connection method.

- **USB Connection (States the USB number)**



- LAN Connection (States the IP address)



- Demo Connection (States Demo mode)



10-3-3. PC File Icon

- GBD File Icon



- CSV File Icon



- Dual sampling File Icon (Ver. 2.20 or later)



This is the icon displayed by performing file playback. Use it as a log of files that have been opened previously. (*The icon won't be displayed when main module data playback is performed on the GL device main module)

10-3-4. Recycle Bin Icon



Disconnect a GL device or delete a file by dropping its icon on the recycle bin using the mouse.

GL Device Icons: Disconnects a GL device or deletes its icon from the screen. The icon will be redisplayed when a search is performed again.

While disconnected: Deletes the icon

While connected: Disconnects the device then deletes the icon

File Icon: Deletes the icon from the screen and erases the previously opened log. The file itself will not be deleted.

10-4. Connection and Disconnection

10-4-1. Manual connection mode and automatic connection mode (Ver. 1.70 or later)

You can choose from two modes for device connections and playback of files. With manual connection, you can choose which devices to connect to from the recognized device icons. With automatic connection, previously connected devices and files being played back will be automatically connected and played back when this software is started. After completion of automatic connection, the status will be the same as that with the manual connection mode. The restored items of the status of settings differ between the two modes. Refer to 10-5. Saving and loading of device status (Ver. 1.70 or later).

- **How to switch between the manual connection mode and the automatic connection mode**

You can switch between the manual connection mode and the automatic connection mode through the control panel within the connection screen. The switching of the mode will be reflected the next time the software is started.

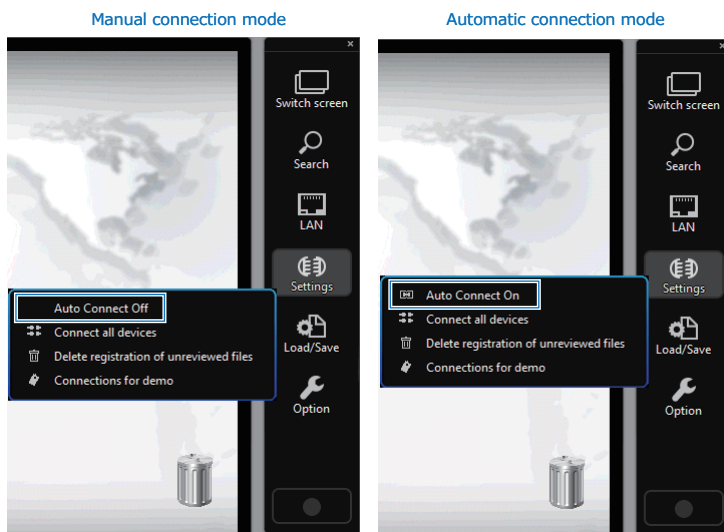

10-4-2. Manual connection mode

Start the connection by clicking on the button over the recognized device icon (playback of the file will begin when clicking on the button over a file icon). A bar will be displayed over the icon and information of the GL device will be obtained. While connecting, click on the button again to cancel the connection. Note that upon connection, the time of the PC will be automatically configured to the GL device.

Connecting



Connection Complete



- **Transition of statuses in the manual connection mode**

The following is the transition of statuses after this software is started in the manual connection mode.



Status	Description
Start	Starts this software.
Search Device	A status where GL devices connected via USB or the LAN I/F are searched for and recognized devices are displayed as icons.
Manual connection status	A status where you can establish connections by clicking on the buttons over the icons of devices found during the device search.

* CHECKPOINT

- Connections cannot be made when the GL device is in playback. Confirm the GL device's operational status.
- This software can only stop recording for the GL device when connecting while the GL device is recording. Normal operations are possible after recording is stopped.
- If the GL device recognizes it via USB connection, it cannot be connected from other software.

10-4-3. Automatic connection mode

With automatic connection, previously connected devices and files being played back will be automatically connected and played back when this software is started. Compared to manual connection, a greater number of statuses are restored with this mode.

- **Transition of status in the automatic connection mode**

The following is the transition of statuses after this software is started in the automatic connection mode.

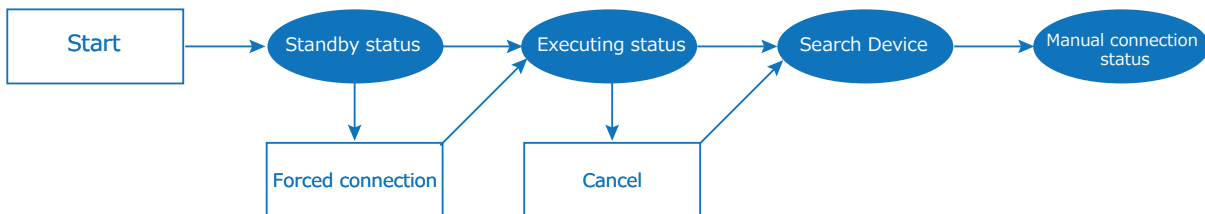

Status	Description
Start	Starts this software.
Standby status	A status where the software is preparing to return to the previously connected settings.
Forced connection	Forces a connection in cases such as when preparations cannot be properly performed to restore the previous connections. *If the wait condition persists, press the "forced connection" button.
Executing status	A status where devices are connected in accordance with the previously connected settings.
Cancel	Cancels device connection and forces a transition to the manual connection status.
Search Device	A status where GL devices connected via USB or the LAN I/F are searched for and recognized devices are displayed as icons.
Manual connection status	A status where you can establish connections by clicking on the buttons over the icons of devices found during the device search.

10-4-4. Device Colors and Device Numbers

Device colors and device numbers will be assigned automatically in the order the devices are recognized. It is possible to confirm the device by using these device colors and numbers when mixing groups of multiple devices.

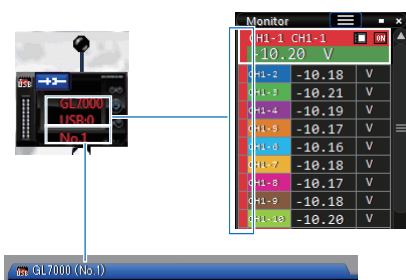

10-4-5. Disconnection and Deletion

Disconnection and deletion have different operations for device icons and file icons.

Remove a plug connected to the PC to disconnect the transmission. And drop the device icon into the recycle bin to disconnect the transmission and delete the icon. (The device icon will reappear when the device search is performed again)

Drop a file icon into the recycle bin to delete the playback log, and the file icon will no longer be displayed automatically the next time the software is launched. (*The file itself will not be deleted from the PC)



10-4-6. Linked Connections (Synchronous and Multi-instrument Connections)

Manages the simultaneous stopping and starting of recording for multiple GL devices. Linked Connections have two methods, synchronous connections and multi-instrument connections.

* Device settings are required for both synchronous and multi-instrument connections. Configure the synchronous settings the same as in 15-4. Data Settings for the data settings and as in 15-5. Trigger Settings for the trigger settings. (* Recording may still be able to be performed even if the settings are not identical, but the data may not be synchronized correctly)

* Files recorded to the PC will be created separately for both synchronous and connections.

• Synchronous Connections

Synchronous connections can connect up to 5 GL7000 modules using optional sync cables. Recordings without errors are possible using multiple GL7000s by synchronizing the recording start timing with the hardware.

The following things are made in synchronous connections

- A start/stop is synchronized by each main module.
- When Trigger is used, Trigger is synchronized by each main module. (Synchronized Recording start)
- Since a clock is synchronized by each main module, even if it records for a long period of time, the time error of each main module is settled in a fixed interval.

(* The synchronous connection is not available for the GL860, GL260, GL980, GL2000, GL240 and GL840.)

• How to Wire Synchronous Connections (Using USB Connections)

Connect the USB cables and sync cables according to the following diagram for synchronous connections. The device that only has the sync cable connected to the OUT terminal will be the master for planning synchronous timing. (*The sync cable is optional)

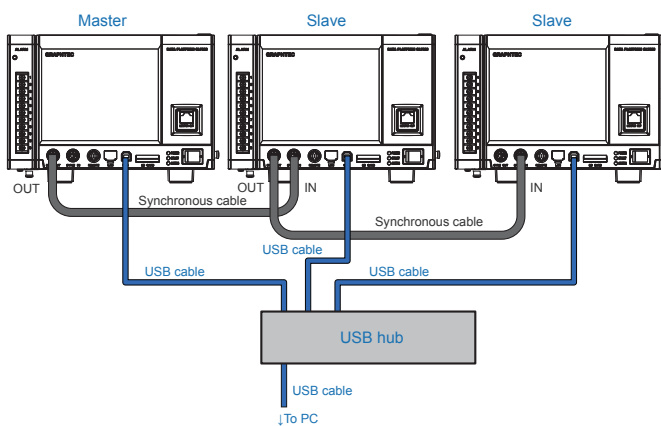

* Also in LAN, it becomes the same.

* Mixture of LAN and USB cannot be performed.

Cross-section of the Sync Cable Termina



OUT Connector



IN Connector

(*Do not connect the same cable into the IN and OUT terminal in one GL7000 module)

• How to Configure Synchronous Connection Settings

Configure the connection settings according to the following diagram using this software. Synchronous

connection cannot be performed automatically, so perform the same connections as those using sync cables.

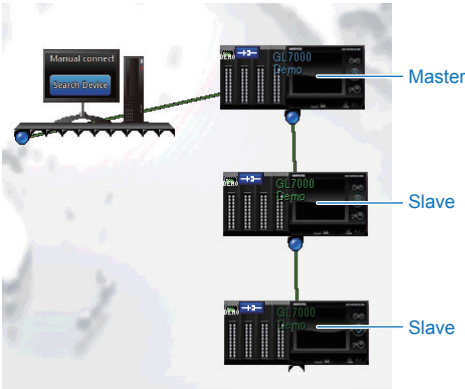

1. Connect the master GL device to the PC.
2. Drag the slave GL device icon's plug to the master device icon.
3. Continue by dragging another slave GL device's plug to the previous slave device.

* Recordings may not be processed correctly if the connections are not performed in the same way as sync cables, so perform the connections in the same order as the sync cables.

* Waveform display and Recording file creation to PC are performed for every main module during synchronous connection.

• **Multi-instrument Connections**

Multi-instrument connections attained when the instrument does not support synchronous connection. Multi-instrument connections are by hardware but a synchronization is not performed.

* Simultaneous timing in multi-instrument connection is not guaranteed.

• **How to Wire Multi-instrument Connections (Using USB Connections)**

Connect the USB cables and sync cables according to the following diagram for multi-instrument connections.

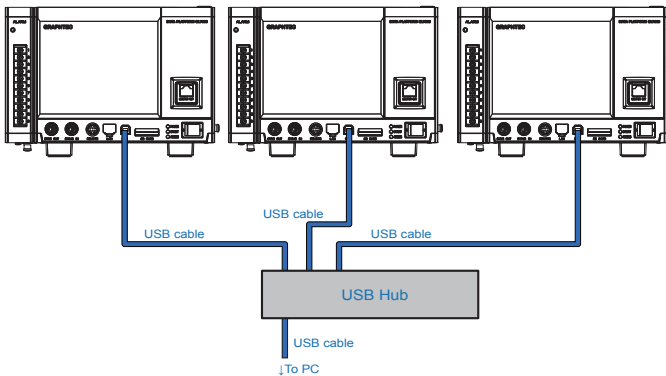

- * Also in LAN, it becomes the same.
- * Mixture of LAN and USB cannot be performed.

• **How to Configure Multi-instrument Connection Settings**

In this application, make the connection settings as shown in the figure below.

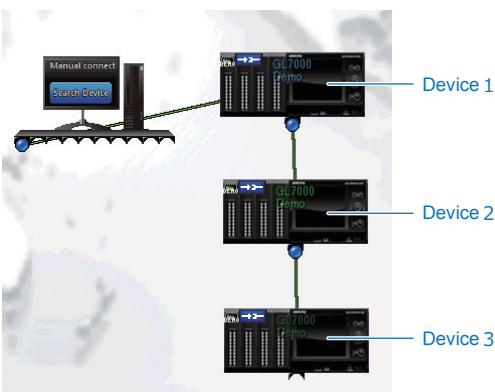

1. Connect the GL device 1 to the PC.
2. Drag the GL device 2 icon's plug to the GL device 1 icon.
3. Continue by dragging another GL device 3 icon's plug to the previous GL device 2.

* Waveform display and Recording file creation to PC are performed for every instrument during multi-instrument connection.

- **Data bind function (for Ver.1.60 and after)**

A file can be created for bound data recorded in a synchronous and multi-instrument connection state onto the same time axis.

* CHECK POINT

* Multi-instrument recording may not be synchronized.

Flow of data bind

1. Starting synchronous and multi-instrument recording
2. Stopping recording
3. Press OK button for message "Do you want to bind recorded data?"

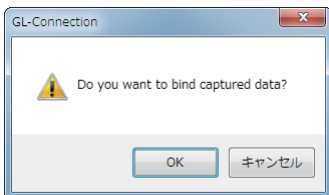

4. Set file format (GBD/CSV), spot settings, and save file, and then press "Execute" button.

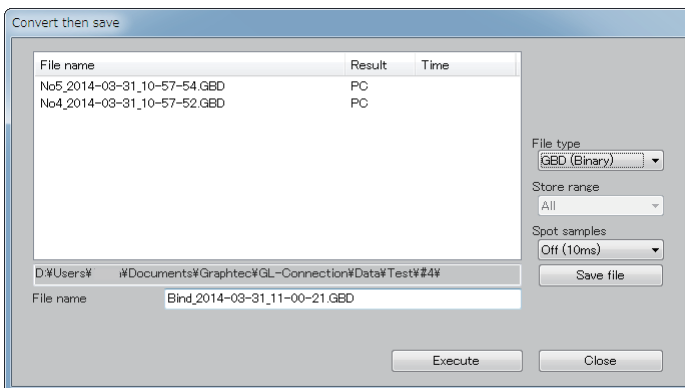

5. When the bind processing is completed, the message "Do you want to open the saved file?" will be displayed. Therefore after confirming the file, playback will be automatically performed when pressing the OK button.

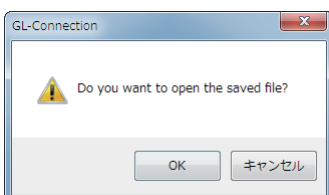

* CHECK POINT

*Recording start time, trigger time and marker settings are based on a master device.

*All bound and saved files will be converted to a GL7000 format.

In addition to the above method, data bind is possible between recorded files or by arbitrary CH combination. Refer to Data bind function (for Ver.1.60 and after) for details.

10-5. Saving and loading of device status (Ver. 1.70 or later)

When a device is connected or a file is played back, the details of the settings are saved with this software and then restored in a state where such previous details are maintained. In addition, it is also possible to save a file containing these details in a place of your choice to later restore the saved status by loading this file.

Normally, the setting details are saved in the following location when this software is closed.

My Documents→ Graphtec → GL-Connection → Ini

* The settings will not be saved when this software is forced to end.

* The previous status will not be restored in cases when the unit configuration of GL devices has been altered from the previous connection or when the interface being connected to has been altered.

* Connected devices and open files will be subject to the restoration. Devices that are not connected and information of files that have not been opened will not be restored.

When choosing to save the settings file, the file will be saved with the extension of “*.acnd”.

10-5-1. Saved details

While the following details will be saved, the restored items will differ between the manual connection mode and the automatic connection mode. The items of (*1) will only be supported with automatic connection.

Category	Item
Common items	Language settings, CSV configuration settings, control lock password, printing settings, playback file history settings
Connection screen items	Icon positions, automatic connection/manual connection mode settings, wallpaper settings, manual LAN connection settings, demo connection (*1), link connection settings (*1)
Main screen common items	Window split settings (*1), device group tab (*1), playback file group tab (*1), main unit playback group tab (*1)
Waveform window items	X-axis scrolling position during playback, AB cursor position during playback, Time/DIV settings, stretch settings of each channel, span settings of each channel, FFT screen zoom
Timeline window items	Time/DIV settings, displayed range settings during playback, AB cursor during X-Y, AB cursor during FFT, display position during FFT
Monitor window items	Display On/Off settings, filter settings
Cursor window items	Time axis switching settings
Device setting items	Amp settings, data settings, trigger settings, alarm settings, X-Y settings, other settings, mail settings (*2), FFT settings (*2), direct EXCEL settings (*2)
Digital window it	Column switching.

10-5-2. Notes regarding the device setting items

The device setting items (*2) of the saved details listed above will not acquire settings information from the GL device upon connection and will be saved in this software only.

10-5-3. Saving and loading settings

The current status of the software will be saved in a settings file of your choice. The settings can be restored by loading this file.

When the settings are loaded, the settings information saved in the settings file will be sent to the GL device to connect to (with the manual connection, this settings information is read from the GL device to connect to). Conditions are required in order to configure this information to the main unit of the GL device. This software will automatically restart when loading settings. Please be aware that this will force the status currently being used to close.

* Please be aware that the settings of the GL device to connect to will be altered when settings are loaded.

- **How to save and load settings**

Each operation can be performed by clicking on the buttons in the control panel.

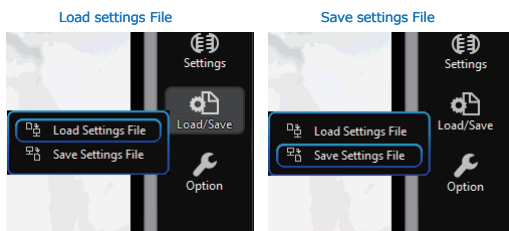

- **Conditions for configuring the main unit of a GL device**

- The connected model has not been altered
- The unit of the connected model is identical
- The connected model is not in the process of recording or playback

10-6. Export logs (Ver. 2.60 or later)

Switches the output setting of the communication log with the device. It is necessary to restart the application when switching.

Right-click on the connected device icon and select "Communication Log" to monitor communication in real time.

Communication logs with devices are stored in the following location

My Documents→Graphtec→GL-Connection→Log

A log file is created when a connection is made with a device. Log files are not created for unconnected devices or files.

If a log file is created for a long period of time, the log file becomes large and may overwhelm the capacity of the PC. Do not output log files for a long time.

10-6-1. Communication Log Confirmation Dialog

The communication log with the device can be checked in real time.

You can operate applications while displaying the communication log screen.

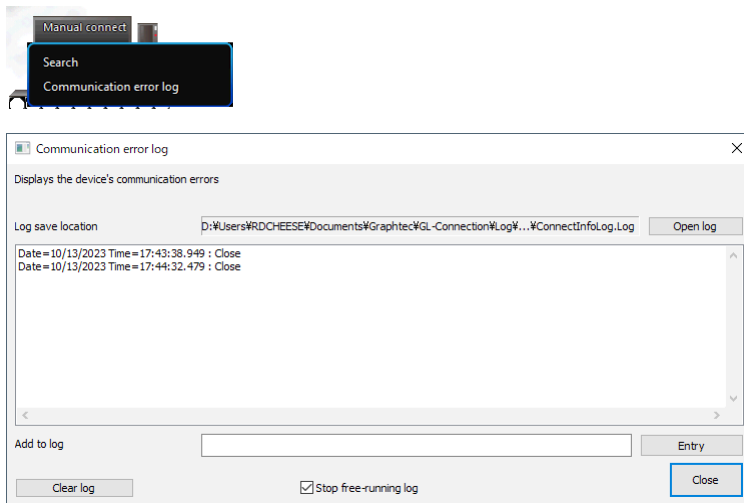

Log destination Displays the destination of the log file being output

Open Log Opens the log file being output

Write Append any characters to the log file

Clear Log Clears the log displayed on the screen.

Clears the log displayed on the screen *Does not clear the log file currently output

Stop logging Stops output to the log file.

Unchecking the checkbox will output to the log file.

Stop logging free running Stops output to the log file regarding free running.

Close Closes the dialog box.

- **How to export logs**

Each operation is performed by clicking a button on the control panel.

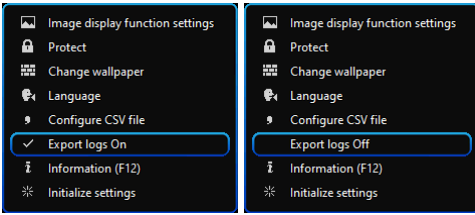

Restart the application when switching

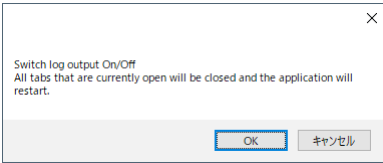

When log output is On, "Debug" is displayed on the application screen.



If log output is performed for a long time, the log file will become large and may overwhelm the capacity of the PC.

Do not export logs for long periods of time.

10-7. Control Panel for the Connection Screen

This explains the control panel on the connection screen.

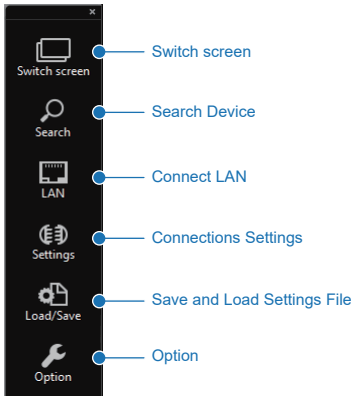

10-7-1. Switch Screen

Changes the displayed screen.

10-7-2. Search GL Devices

Searches for connected devices and displays the icons for the detected devices on the screen. Devices that can be detected using a search are either connected to the PC using USB, or are devices such as the GL7000 that support automatic LAN recognition when connected using LAN.

- Models that support LAN search: GL7000, GL980, GL2000, GL860, GL260, GL240, GL840 and GLT400

10-7-3. LAN connection

Devices that do not support automatic LAN recognition can be connected using LAN with manual settings. Connect to a GL device by inputting the IP address or port number set in 5-3. Setting the USB ID or the IP Address

• Connection Screen

Set the IP address and port number set on the GL device main module, and press the connect button. If entering a domain name, select a domain and then enter the name.

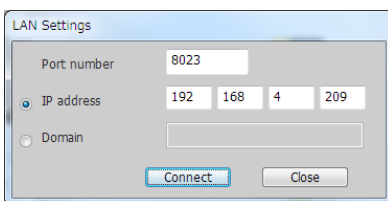

10-7-4. Connection Settings

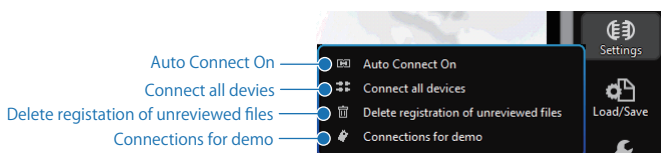

• Auto Connect On

The software will switch between the manual connection mode and the automatic connection mode.

The switched mode will be effective from the next time the software is started. Refer to 10-4-1. Manual

connection mode and automatic connection mode (Ver. 1.70 or later) for details.

- **Connect all devices**

In a state where multiple devices are recognized, a connection will be made with all devices at once.

- **Delete registration of unreviewd files**

Unregisters the unplayed file icons at once. The actual files will not be deleted.

- **Connections for Demo**

Repeatedly displays recorded files and displays them as demo waveforms. Default demo waveforms will be installed during this software's installation (Go to My Documents → Graphtec → GL-Connection → Data → Demo.gbd on the PC).

The following operations can be performed using demo connections.

- Waveform display/Waveform operation
- Display the digital monitor
- Browse the settings
- Group Creation

10-7-5. Load Settings File

By loading the file that has been saved by the operation of saving a settings file, the settings environment at the time of the save will be restored. Please be aware that this software will restart when loading this file. Refer to 10-5. Saving and loading of device status (Ver. 1.70 or later) for details.

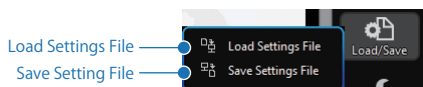

10-7-6. Option Settings

Used for changing the password to lock operations, display language, etc.

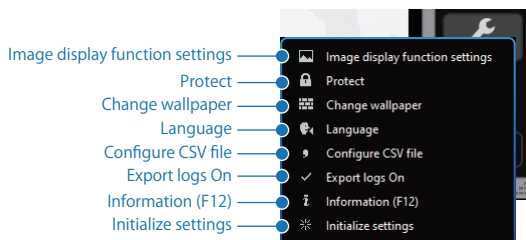

- **Image display function setting (Ver. 2.40 and later)**

Configures the image display function. For details on the image display function, see section "16-6. Image display function (Ver. 2.40 and later)".

- **Protect Setting**

You can set the password used to lock your device. Pressing the OK button will end the application, lock the operation and you will be unable to bring up the control panel, use window controls, or end the application.

Password Input Screen

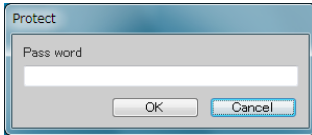

Device Lock Icon



To release the lock on the device, press the device lock icon, and enter the password. The control panel and window operations will be displayed again, and you may resume operations. In the event of a forced termination of the software, the locked condition will not be preserved. The next time it is started up, it will be unlocked.

- **Change Wallpaper**

You may load a custom BMP file and set it to be your wallpaper. If you set your wallpaper to a picture of measurement environment, aligning your PC location and GL device location will lead to a closer measurement environment image.

- **Language Setting**

You can change the display language.

It is necessary to restart this software in order for the settings to be reflected.



- **CSV Configuration Settings**

Sends you to CSV Data Delimiter and separator options. Please set to the same language as the PC you are currently using. CSV Config settings for Recording and Output must be the same as CSV data for playback, or else it will not properly play back.

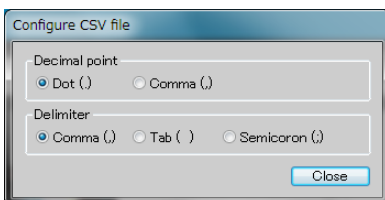

Decimal Point : You can change the character used for decimal points.

Delimiter: You can change the character used to separate two items.

The initial value is determined by language.

Language	Decimal point	Delimiter
English	Dot (.)	Comma (,)
Japanese	Dot (.)	Comma (,)
French	Comma (,)	Semicolon (;)
German	Comma (,)	Semicolon (;)

Language	Decimal point	Delimiter
Chinese	Dot (.)	Comma (,)
Korean	Dot (.)	Comma (,)
Spanish	Comma (,)	Semicolon (;)
Russian	Comma (,)	Semicolon (;)

- **Export Logs**

Switches between device and communication log output settings. See “10-6. Export Log (Ver2.60 and later)” for details..

- **Information**

Shows the version, revision, history of added functions (Ver. 2.40 and later) of this software.

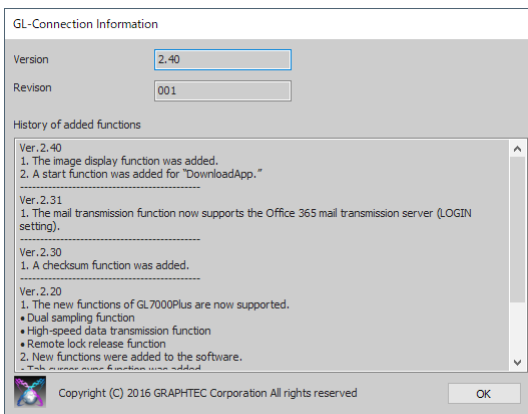

- **Installation Initialization**

The settings of this software will be initialized. After this operation has been executed, the initialization will be reflected from the next time this software is started. Refer to 10-5. Saving and loading of device status (Ver. 1.70 or later) for information on the details that will be initialized. * As the initialization will also initialize the language settings, you will need to reconfigure the language when the program starts. * The settings of the main unit will not be initialized.

11. Main Screen

You can access the Waveform Display and Digital Display from the main screen. The main screen can separate into up to 4 window displays. On start up 1 window will be displayed. Refer to “11-11-1. Navigation Window”.



4 Section Display Example



- Change window size (ver 2.00 or later)

When the screen is split, you can change the size of each window by using the mouse to drag the dividing boundary.



11-1. Tabs

Connected GL devices and files will displayed on their own tabs in the Connection Screen. Tabs can be active or inactive, clicking a tab will make it active. You can manipulate active tabs using the Control Panel. If a tab is dragged with the mouse, the navigation window is displayed, and it is possible to use multi-window features, group creation, or deletion. For information on tab features, please see “You can access the Waveform Display and Digital Display from the main screen. The main screen can separate into up to 4 window displays. On start up 1 window will be displayed. Refer to “11-11-1. Navigation Window”. In 1 window, a maximum of 20 tabs can be created.

11-1-1. Tab Elements and Status

There are device tabs, filter tabs, and group tabs. Currently selected tabs will be displayed in blue as active tabs and inactive tabs will be displayed in black. In the device and file tabs, the device number is displayed. This number is like the device color and used to differentiate tabs.

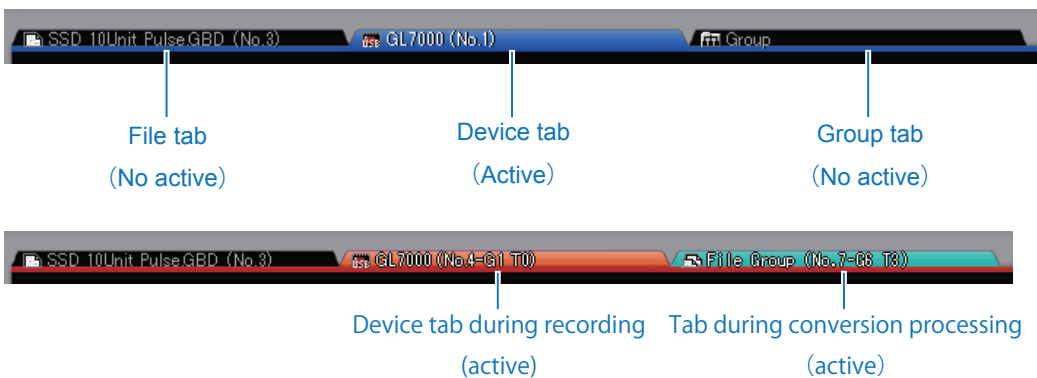







* Device tabs during recording and saving tabs cannot be deleted

11-1-2. Tab Icon Types

Elements	Name	Explanation
Device Tab	USB Connection Icon	Devices connected by USB are shown.
	LAN Connection Icon	Devices connected by LAN are shown.
	Demo Connection	Devices connected by DEMO are shown.
File Tab	File Icon	Shows tabs with file playback.
	Device Playback Icon	Shows tabs with file playback.
	Dual sampling / Current (Low-speed) playback icon	Displays the current (low-speed) playback tab recorded with the dial sampling function. (GL7000 version 2.00 or later)
	Dual sampling / Event (High-speed) playback icon	Displays the event (high-speed) playback tab recorded with the dial sampling function. (GL7000 version 2.00 or later)
	Tab cursor sync icon	Displays the file cursor sync tab.
Group Tab	Free Running Group Icon	Displays the Free Running Group tab. For information on group functions, refer to “16-2. Group functions”
	File Group Icon	Displays the File Group tab. For information on group functions, refer to “16-2. Group functions”

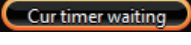
11-2. Status

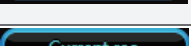
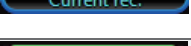
Displays the operational status of the Screen.

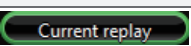
Screen	Name	Explanation
	Free-Running status	When connected to GL functions, this displays waveform.
	Armed status	In recording state, waiting for trigger detection.
	Current timer waiting status	In recording state, holding for timerdetection. (GL7000 version 2.00 or later)
	Recording In Progress status	During recording, the trigger is being detected and will record.
	Dual sampling recording status	The recording state of the dual sampling function. (GL7000 version 2.00 or later)
	Review status	Files of the PC are currently in playback, or the data of the GL device is in playback.
	Current Review status	The current (low-speed) data playback state of the dual sampling function. (GL7000 version 2.00 or later)
	Event Review status	The event (high-speed) data playback state of the dual sampling function. (GL7000 version 2.00 or later)

11-3. Window Button

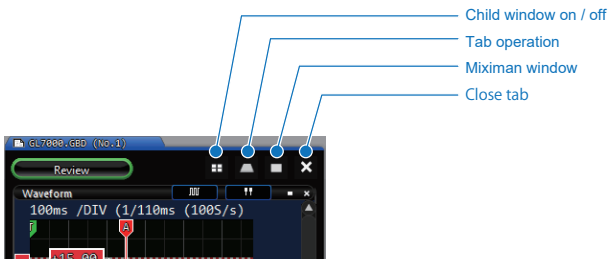

11-3-1. Child Window On / Off

Sets whether to turn each child window On/Off. Some of the windows cannot be displayed depending on the operating status. If the display screen is too small, the window may automatically close. Be sure to display the necessary window every time a change is made.

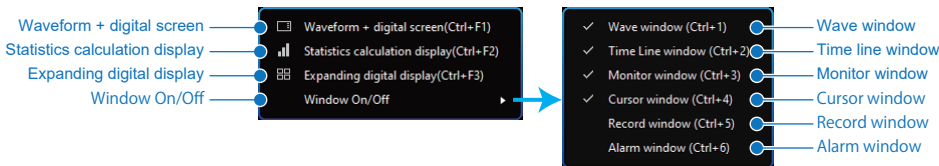

Name	Explanation
Waveform + digital screen	Displays waveform displays and digital screens.
Statistics calculation display	Displays statistical calculations.
Expanding digital display	Displays enlarged digital values.
Window On/Off	On/Off setting for each child window.
Waveform Window	Open or close Waveform Window.
Time Line Window	Open or close Time Line Window.
Monitor Window	Open or close Monitor Window.
Cursor Window	Open or close Cursor Window. Only available during playback.
Recording Information Window	Open or close Recording Information Window. The content will differ depending on the operating status.
Alarm Window	Open or close Alarm Window.
Image Window	Opens and closes the image window. (Ver. 2.40 and later) Displayed only during playback. Displayed only when "Enable the image display function" is selected in the image settings of options.

11-3-2. Tab operation

Splits the screen or creates group tabs with the tab that is selected. For details, refer to "11-11-1. Navigation Window".

11-3-3. Miximize

When the screen is split, the Waveform Window can be temporarily displayed in the full screen mode so that it is easier to see. Tabs cannot be operated during the full screen mode.

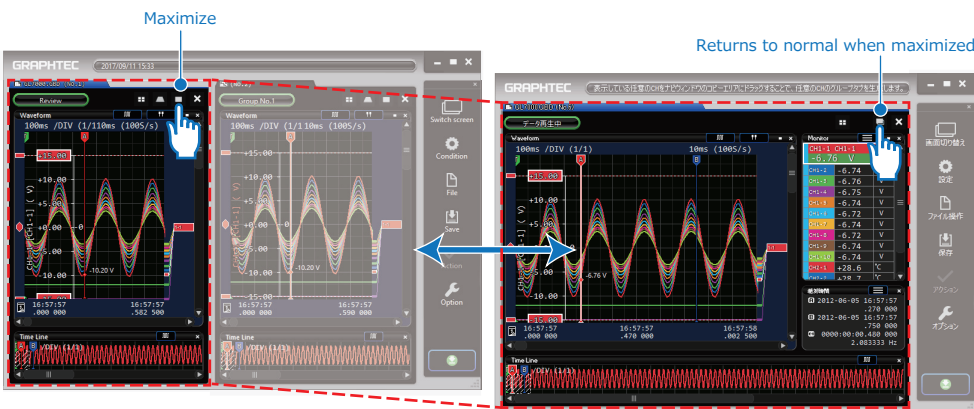

11-3-4. Close Tab

Closes the corresponding tab window. When a device tab is closed, the connection is disabled. When a file tab is closed, playback is ended.

11-3-5. Maximizing and Closing a Child Window

Operations can be performed to maximize and close each Child Window. When maximized, the corresponding Child Window will be temporarily displayed in the maximized state. With such as the Monitor Window, the displayed content may change depending on whether the window is maximized. The Close button operates in the same way as Off for On/Off of the Child Window.

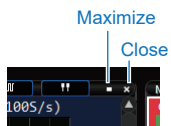

11-4. Waveform Window

The window for displaying the waveform. You can switch the waveform display screen between the different display methods of Y-T, X-Y, and FFT. Although the content of the displayed waveform is cleared when switching between waveform modes, recorded data will not be erased while recording, etc. You can switch between the different waveform modes by using the waveform operation button.

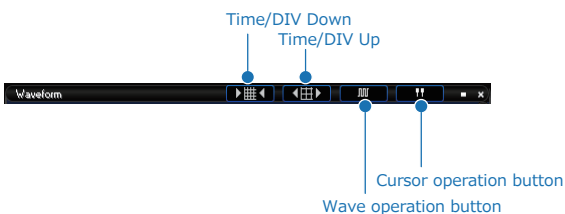

Name	Explanation
Waveform operation button	Used to operate the waveform display. For details, refer to the chapters on each waveform mode.
Cursor operation button	Used to operate the cursor. Only available during playback. For details, refer to the chapters on each waveform mode.
Time/DIV Up	Increase the Time/DIV value to enlarge the waveform.
Time/DIV Down	Decrease the Time/DIV value to shrink the waveform.

11-4-1. Switch wave mode

You can change the waveform mode by using the waveform operation button.

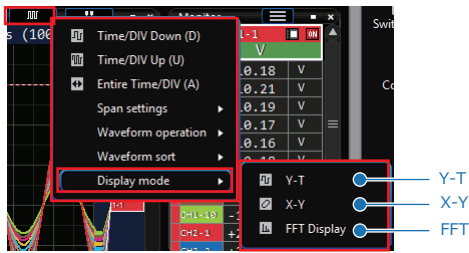

Name	Explanation
Y-T Waveform Window	Change screen to Y-T waveform. For information on Y-T Waveform Window, refer to "12. Y-T Waveform Mode"
X-Y Waveform Window	Change screen to X-Y waveform. For information on X-Y Waveform Window, refer to "13. X-Y Waveform Mode"
FFT Waveform Window	Change the current display to the Y-T waveform. For more information about the FFT Waveform Window, refer to "14. FFT Waveform Mode"

11-4-2. Y-T Waveform Display

The input signal level is displayed on the Y axis, and time is displayed on the X axis of this graph.

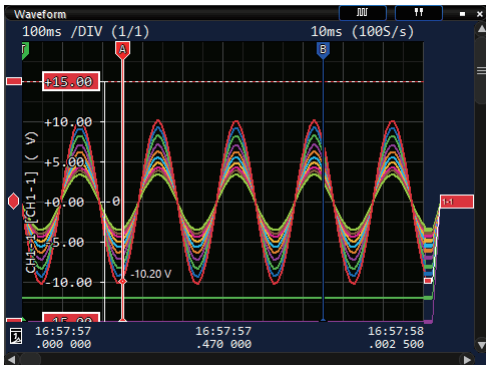

11-4-3. X-Y Waveform Display

After assigning the input signal to the X axis and the Y axis, the X and Y 's signal can correlatively be displayed with wave form display. The X-Y waveform can at maximum show 4 channels. The X-Y waveform can only be displayed during free running and during recording. During playback the X-Y waveform cannot be displayed.

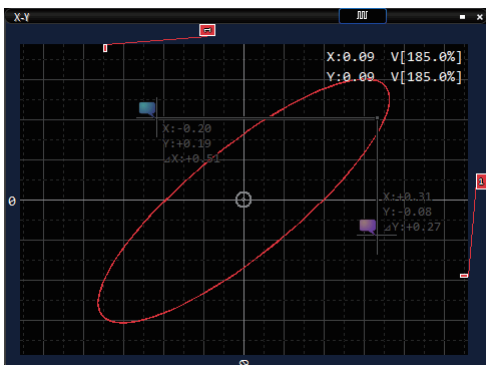

11-4-4. FFT Waveform Display

The frequency is displayed on the X axis, and the level is displayed on the Y axis of this graph. During free running, the waveform is displayed in real-time, or any range of the waveform can be displayed after replaying the recorded file. Also, check the difference between the levels as well as the frequency width and detect the peak with the cursor A and B.

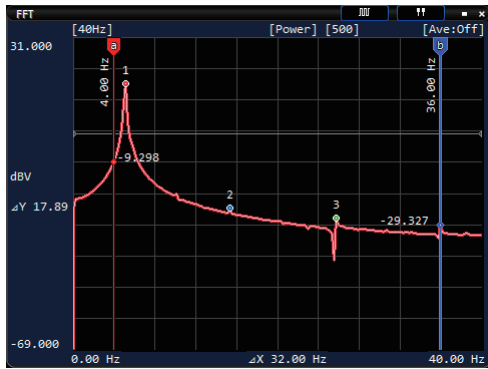

11-5. Time Line Window

You can use the Y-T wave form window to view everything. The digital monitor allows 1 channel's wave form to be displayed. During replaying X-Y or FFT, this window is used to set the processing range.

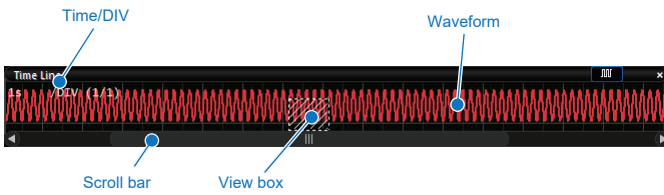

11-6. Monitor Window

This window displays the signal's level value. During free running or recording, new information is updated every 0.5 seconds. During playback, selecting either cursor A or B will display the signal level value of the chosen cursor. Depending on the window size, all modes (Digital, Statistical Calculation, Expanded Digital) can be used.

11-6-1. Digital Display

This display mode shows wave form displays lined up with each other.

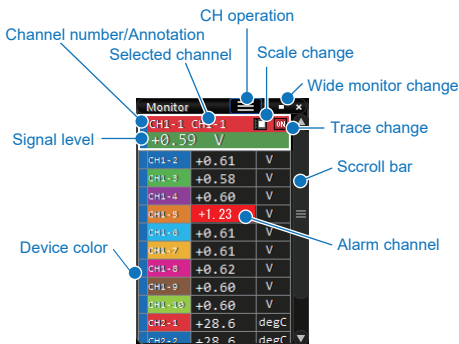

11-6-2. Statistical Calculation Display

This mode is a wide range display that does not show waveform display. In wide display, statistics calculations can be performed.

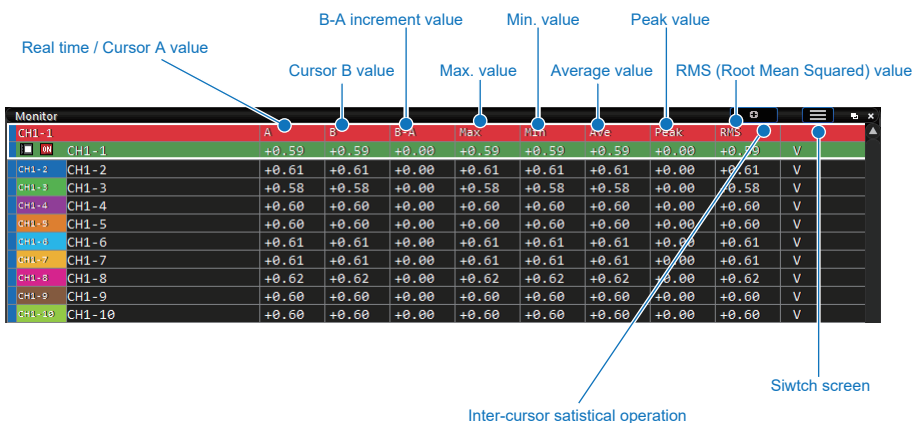

11-6-3. Expanded Digital Display

You can increase the size of the characters during wide display mode.

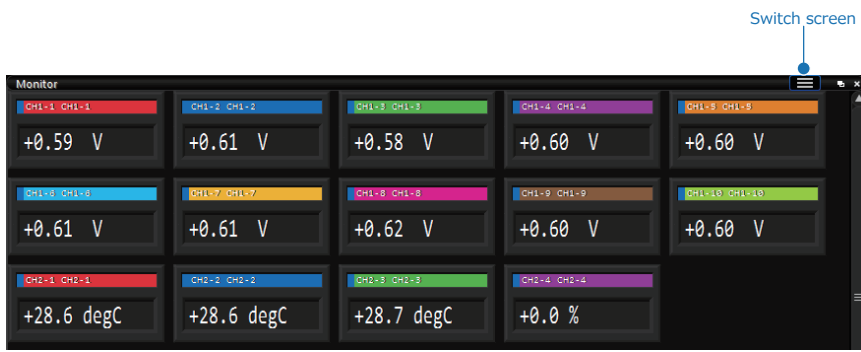

Name	Explanation
Switch column	Toggles the number of CHs displayed per line. 5: Displays up to 5 channels per line. 10: Displays up to 10 channels per line.
Switch screen	Switches the screen.

11-7. Alarm Output Window

Displays the Alarm Output Lamp. Displays the alarm data of the selected cursor during playback.

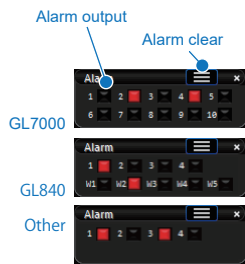

Name	Explanation
Alarm output	The output port of an alarm that has been triggered will be lit up red.
Alarm Clear	If the alarm clear is used when alarm hold setting is set to On for free-running or currently recording device, the triggered alarm will be cleared. For Alarm hold settings, please refer to "15-6. Alarm Settings"

11-8. Recording Information Window



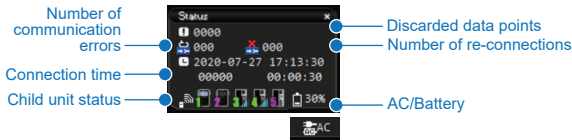

Displays time passed or time remaining during recording. Displays the time of the recording data during playback.

11-8-1. Free-running in Progress

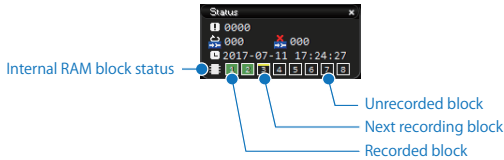

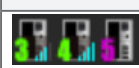
When recording on the internal RAM of GL980/GL2000

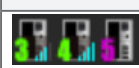

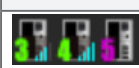
Name	Explanation				
Discarded Data Points	Discarded Data Count When Free-running data is sent from the device in real time, the amount of data that could not be sent in time is counted and displayed. When the Discarded Data Count is counted up, the free-running recording data are not being sent in time, so please select a lower sampling time.				
Number of communication errors	The number of communication errors occurred is displayed.				
Number of re-connections	The number of re-connections attempted is displayed.				
Connection time	Elapsed time will be displayed after device connection Connection date and time (year, date, day, time) Connection elapsed time (date and time)				
Child unit status	When the WL sensor (wireless sensor) or RT terminal (remote terminal) is connected to the GL840, the connection status of each sensor is displayed. Compatible with GL800 V1.60 or later. <table border="1" data-bbox="536 1176 1270 1440"> <tr> <td></td> <td>Displays the connection status of the WL (wireless sensor). Green: Registered/recognized status. Pink: The device has not been searched.</td> </tr> <tr> <td></td> <td>Displays the connection status of RT (remote terminal). Green: Registered/recognized status. Pink: The device has not been searched. In the case of wireless connection, the signal strength is displayed.</td> </tr> </table>		Displays the connection status of the WL (wireless sensor). Green: Registered/recognized status. Pink: The device has not been searched.		Displays the connection status of RT (remote terminal). Green: Registered/recognized status. Pink: The device has not been searched. In the case of wireless connection, the signal strength is displayed.
	Displays the connection status of the WL (wireless sensor). Green: Registered/recognized status. Pink: The device has not been searched.				
	Displays the connection status of RT (remote terminal). Green: Registered/recognized status. Pink: The device has not been searched. In the case of wireless connection, the signal strength is displayed.				
AC/Battery	Displays the remaining battery level when the unit is powered by AC power, DC power, or battery. This content is also displayed during recording. (Only compatible with GL840 V1.60 or later)				
Internal RAM block status	Indicates the status of RAM blocks for internal RAM recording when using GL980/GL2000.				
Unrecorded block	Indicates that the RAM block has not been used for recording.				
Next recording block	Indicates the block that will be used for the next recording. A yellow line will be displayed on the top of the block.				
Recorded block	Indicates that the RAM block has already been used for recording.				

11-8-2. Recording

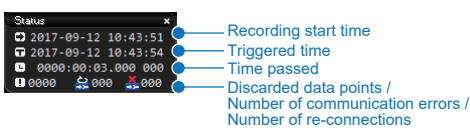

When recording on the internal RAM of GL980/GL2000

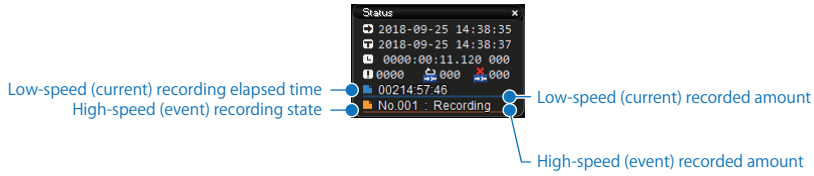
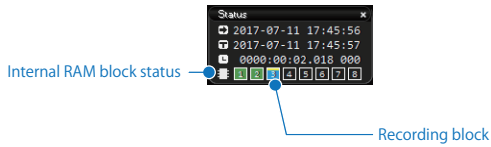

Name	Explanation
Recording Start Time	Displays the time that recording was started.
Triggered Time	Displays the time that the start trigger is activated.
Time Passed	Displays the amount of time that has passed since the trigger activated.
Discarded Data Points	Discarded Data Count When Free-running data is sent from the device in real time, the amount of data that is sent in time is counted and displayed. When the Discarded Data Count is counted up, the free-running recording data are not being sent in time, so please select a lower sampling time. When recording to the GL device itself, there is no effect on the data in the device.
Number of communication errors	The number of communication errors occurred is displayed.
Number of re-connections	The number of re-connections attempted is displayed.
Recording block	Indicates that the RAM block is currently being used for recording.
Current (low-speed) recording elapsed time	Displays the elapsed time for current (low-speed) recording.
Current (low-speed) recorded amount	Displays the current (low-speed) recorded amount in regard to the total recording capacity.
Event (high-speed) recording state	Displays the number of event (high-speed) recording instances and the recording state.
Event (high-speed) recorded amount	Displays the event (high-speed) recorded amount in regard to the total recording capacity.

11-8-3. Review



Name	Explanation
Recording Start Time	Displays the time that recording was started.
Triggered Time	Displays the time that the start trigger is activated.
Recording Stop Time	Displays the time when recording was stopped.

11-9. Cursor Information Window

Displays time information above Cursor A or Cursor B during playback.

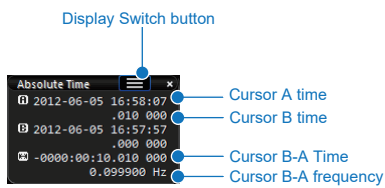

Name	Explanation
Cursor A time	Displays the time informations above the various cursors. Or, if the [A] or [B] is pressed, the A and the B Cursors will move to display waveform and, Cursor A and B's time also changes to the point that was moved to.
Cursor B time	
Cursor B-A Time	Displays the time for Cursor B-A
Cursor B-A Time Difference Frequency	Displays the frequency for Cursor B-A
Display Switch button	Switches between the Time display and Points display.
Time display switching button	Switching is performed in absolute time, relative time and point display.

11-10. Image window (Ver. 2.40 and later)

During playback, the image display function shows an image in the window when the relevant image exists. For details on the image display function, see section "16-6. Image display function (Ver. 2.40 and later)". The image timestamp and image switch buttons are displayed when the mouse pointer is on the image window.

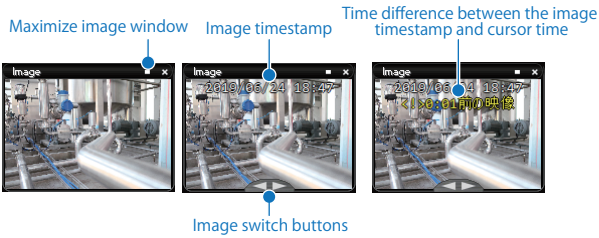

Name	Explanation
Maximize image window	Maximizes the image window to view the image in a large window.
Image timestamp	Shows the image timestamp. If there is a time difference between the image timestamp and the cursor position, the difference is shown in the second row.
Image switch buttons	Clicking the left button shows the previous image. Clicking the right button shows the next image. Hold down the button to switch the image repetitively.

When the image window is maximized



Image window when there is no image

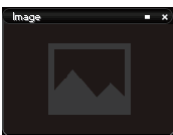



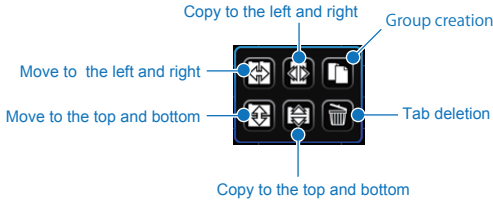

11-11. Other Windows

11-11-1. Navigation Window

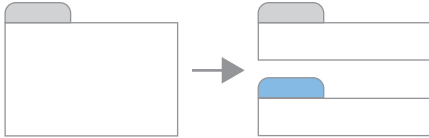
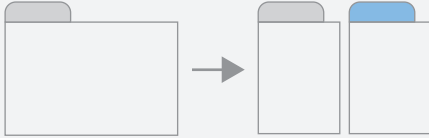
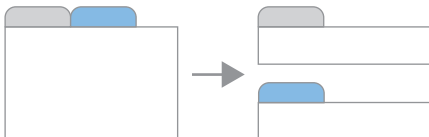
The Drag function for tabs or digital monitor windows can be performed by accessing the Navigation Window. In the Navigation Window, you can divide the screen into sections, or create group tabs. For more information about the grouping function, refer to “16-2. Group functions”

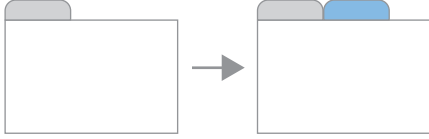

Name	Explanation
Copy to the top and bottom	Divides the selected tab into the two tabs vertically (upper and lower). 
Copy to the left and right	Divides the selected tab into the two tabs horizontally (left and right). 
Move to the top and bottom	Move the selected tabs vertically in the movable direction. When two tabs or more is not present in the same window, this function is not available. 
Move to the left and right	Move the selected tabs horizontally in the movable direction. When two tabs or more is not present in the same window, this function is not available. 
Group Creation	Create the selected tab by dragging on the the tab or the channel in the digital monitor. 
Tab Deletion	Drag the tab on the Delete button in the Navigation Window to delete the tab. When the Device tab is deleted, the connection is disabled. When File tab is deleted, the reviewing is finished. 

- Divided Screen

<Default>

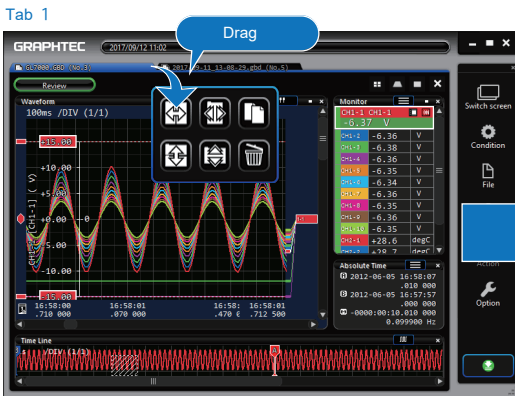

<Divides the tab horizontally>

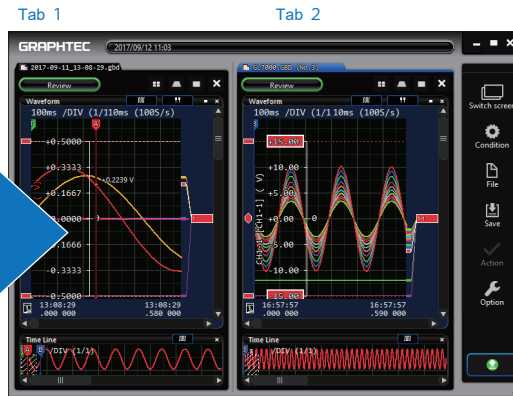

When the Tab 2 is dragged on “Right Section” in the active navigation window, the two-screen section display that the tab 2 is placed on the right side appears.

- Screen with Group Tabs

<Example of group creation from the Device tab>

Device tab



Device tab

Copy group tab



When the Device tab is dropped into “group creation” in the navigation window, the group tab that the Equipment tab is copied is created.

<Example of group creation from the Monitor Window channel>

Device tab

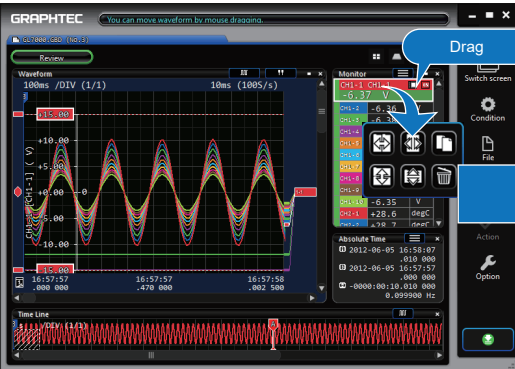

Device tab

Copy group tab

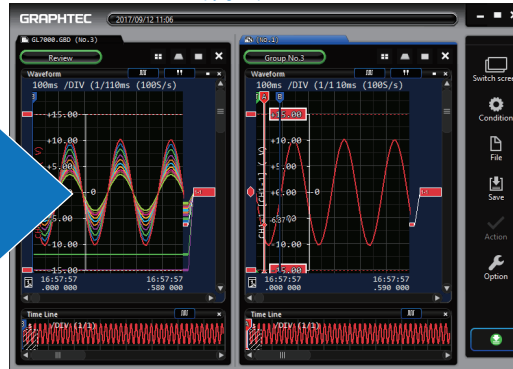

When the channel on the monitor window is selected and then dropped into “Group Creation” in the navigation window, the group tab that the selected channel is copied is created, and the Waveform Display with the selected channel only appears.

- * When canceling a group window, please delete the group tab using the follow “Tab Deletion Screen”.
- * CH cannot copy in the state of Trace OFF. Please copy in the state of Trace ON.

- **Tab Deletion Screen**

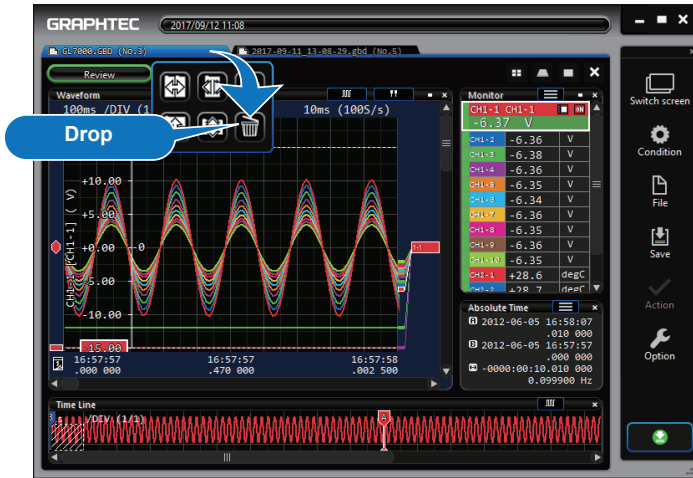

By dropping any tab into “Tab Deletion”, the tab display is deleted.

11-12. Main Screen Control Panel

11-12-1. Main Panel

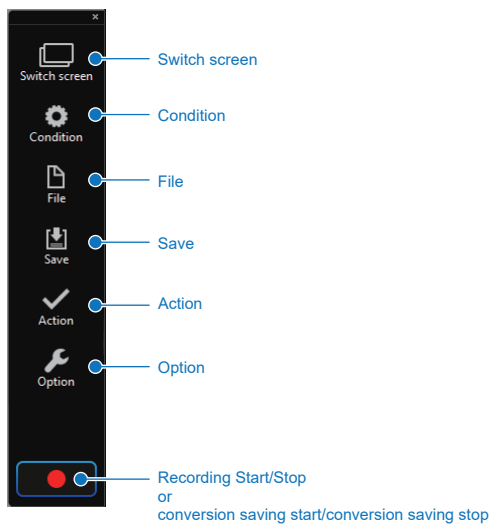

Name	Explanation
Switch screen	Connection window and Main window are changed.
Condition	Set options for main module. This is available when a Device Tab is selected. For Device Settings, please refer to "15. Device Settings"
File	Used to perform operations related to files.
Save	Used to perform operations related to saving.
Action	Used to perform operations related to actions.
Option	Used to perform operations related to options.
Recording Start/Stop or conversion saving start/conversion saving stop	To start/stop recording. You can only perform starting and stopping from the Device Tab. When device tab is active: a recording start/stop operation is performed. Recording start/stop is only valid on the device tab. When playback tab is active: save converted file, save binding start/stop will be performed. When playback tab is file playback or device playback: save converted file will be performed. When playback tab is group playback: saving binding or save binding stop will be performed.

11-12-2. Condition

Set options for main module. This is available when a Device Tab is selected. For Device Settings, please refer to "15. Device Settings"

11-12-3. File

Feerunning

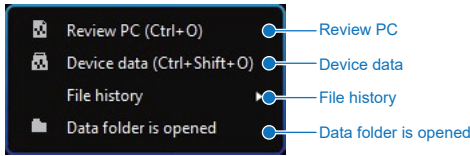

Recoring

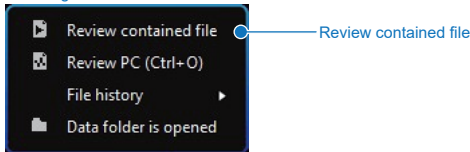

Replaying

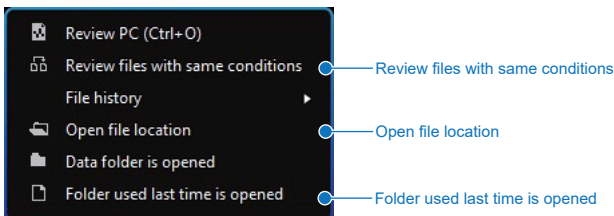

Name	Explanation
Review contained file	Performs playback of up to the number of files recorded during recording. As an automatic update of the data will not be performed, be sure to execute playback again when updating the data.
Review PC	Performs playback of the data file recorded on a PC.
Review files with same conditions	During playback of a PC file, playback can be performed upon replacing the file with a file having the same conditions while maintaining the status during the playback.
Device data	Data from the main module can be manipulated or played back. Only available when the device is connected.
File history	Displays the history of files that have been recorded and files that have been played back. Any file can be played back again from this file history list.
Data folder is opened	Opens the prescribed data folder of this software.
Folder used last time is opened	Opens the folder containing the previously played back file. This is available during file playback.
Open file location	Opens the destination folder for the currently playing data.

- **Review contained file**

Performs playback of up to the number of files recorded during recording. As an automatic update of the data will not be performed, be sure to execute playback again when updating the data.

- **Review PC File**

Play back a file recorded to the PC. Please select a file to be played back. To play back a file it must be either a GBD (Binary) format device file supported by GL-Connection, or a CSV (Text) format file.

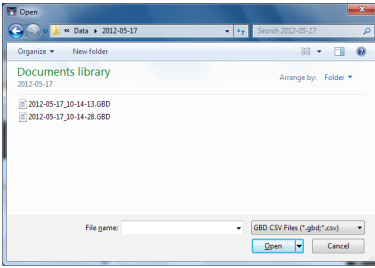

Also, the file can be played by directly dragging and dropping the file to the main window.

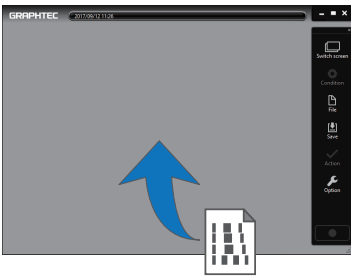

- **Review files with same conditions**

During playback of a PC file, playback can be performed upon replacing the file with a file having the same conditions while maintaining the status during the playback. The items that can be maintained with the same conditions are as follows:

Name	Explanation
Same conditions	Device model, number of equipped units (GL7000), file format (GBD/CSV), number of CH
Items that can be maintained	Waveform display mode, scroll position, screen split status, Time/DIV, span, stretch, AB cursor position
Items not maintained	Line color, annotations

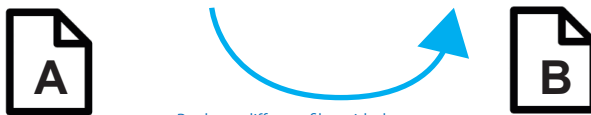
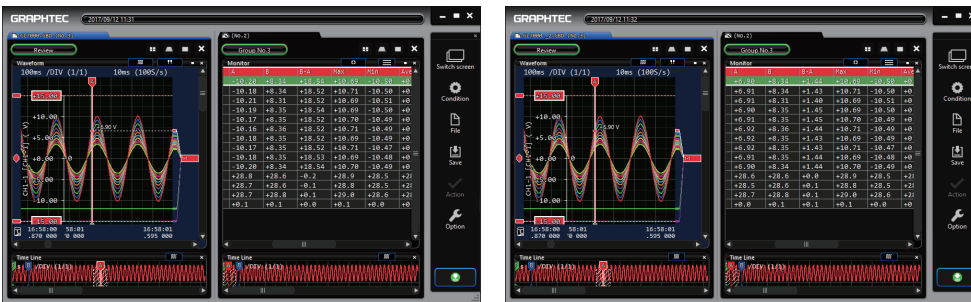

Replaces different files with the same status

It is also possible to perform playback of a file with the same conditions by dragging the file with the same conditions and while holding the [Shift] key and dropping this in the tab window in which you wish to execute playback of the file with the same conditions.



• Main Module Data

Data from the main module can be manipulated or played back. Only available when the device is connected. It is possible to initialize a device from GL-Config.

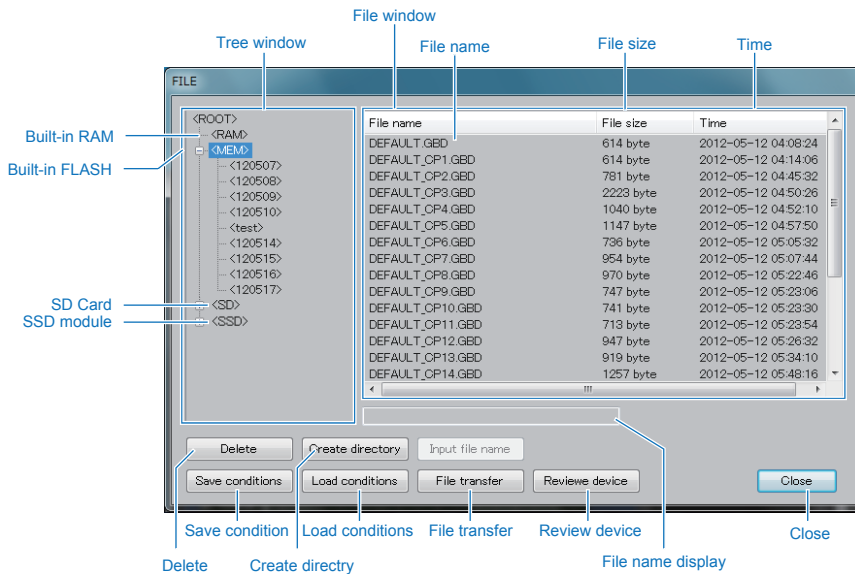

Name	Explanation
Tree Window	Display all devices recognized by the main module. Internal RAM Internal Flash SD Card SSD module USB memory (* Applicable model only)
File wndow	A general overview of the contents of the device selected by Tree Window is displayed. File Name File Size Update Time
Delete	Deletes a folder or file.
Create directory	Creates a new folder in the designate path of the tree window.
File name display	Displays the file name entered during File Name Entry.
Save conditions	Saves the main settings to the main module.
Load conditions	Loads the previously saved settings file. (*Files with a different organization from the device's amp module cannot be loaded).
File transfer	Transfers the file on the main module to the PC.
Review device	Replays back the device data.
Close	Closes the display.

File transfer

When the GL7000 version 2.00 or later is used in combination with this software version 2.20 or later, it is possible to utilize the high-speed file transfer function, enabling data transfer that is faster than all other versions.

The internal flash memory, SD memory card, and expanded SSD module all operate at high speed. The speed of the internal RAM does not increase.



Name	Explanation
Transfer status display	Displays the status of the data transfer.
Transfer state display	Displays the state during transfer. Some operations in the tab are disabled during data transfer.
Details button	Press the details button to bring up the transfer details screen.

Transfer details screen

When transferring multiple main unit files, it is possible to check the file transfer order and status on this screen.

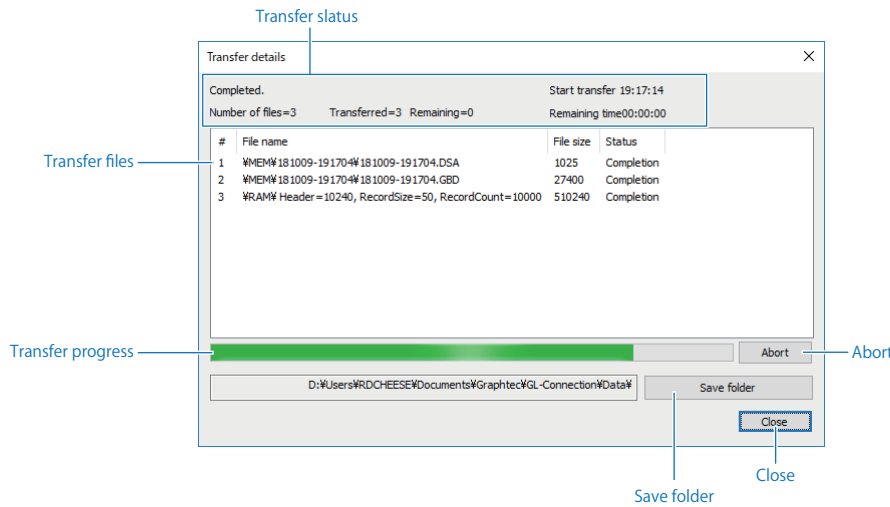

Name	Explanation
Transfer status	Displays the transfer status.
Transfer files	Displays the transfer files and their status.
Transfer progress	Displays the progress of the file transfer.
Save folder	Displays the name of the save folder.

Abort	Press this button to cancel the transfer.
Save folder settings	Press this button to set the file save folder.
Close	Closes the screen.

- **File History**

Displays the history of files that have been recorded and files that have been played back. Any file can be played back by selecting it from this file history list. The history is retained for a maximum of 10 files.

```
C:\Users\RDLEMON\Documents\Graphtec\GL-Connection\Data\GL7000.GBD
C:\Users\RDLEMON\Documents\Graphtec\GL-Connection\Data\Sample1.GBD
C:\Users\RDLEMON\Documents\Graphtec\GL-Connection\Data\GL7000_2.GBD
C:\Users\RDLEMON\Documents\Graph...7-06-20\Bind_2017-06-23_17-27-10.GBD
C:\Users\RDLEMON\Documents\Graph...\Convert_No3_2017-07-11_17-49-31.GBD
C:\Users\RDLEMON\Documents\Graphtec\GL-Connection\Data\Demo.GBD
C:\Users\RDLEMON\Documents\Graph... Convert_No11_2016-12-15_17-13-01.CSV
C:\Users\RDLEMON\Documents\Graph... Convert_No11_2016-12-15_17-12-47.CSV
C:\Users\RDLEMON\Documents\Graph...\Convert_No2_2016-12-27_11-43-06.GBD
C:\Users\RDLEMON\Documents\Graph...\Convert_No2_2016-12-27_11-18-19.GBD
```

- **Data folder is opened**

Open the data folder specified by this software. The default is C: \ Users \ <user name> \ Documents \ Graphtec \GL - Connection\Data.

- **Folder used last time is opened**

Open the folder that the file was played last time.

- **Open file location**

Opens the folder where the data being played back is stored during PC file playback. This applies to files recorded on the PC.

11-12-4. Save

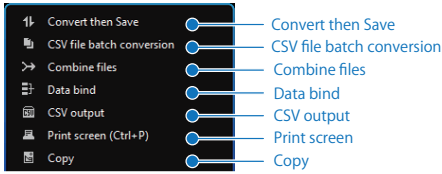

Name	Explanation
Convert then save	Data from the main module can be manipulated or played back. Only available when the device is connected. When extracting the data between cursors and saving as GBD file, checksum will be added if the original file format is GBD and checksum matches. In case of combining files and binding file, checksum will not be added. Please refer to ""Checksum verification (Ver. 2.30 or later)"".
CSV file batch conversion	Changing the formats of multiple GBD (binary) files to CSV (text) format as a batch.
Combine files	Connect multiple GBD (binary) files above the time axis. Only possible for files with the same conditions.
Data bind (for Ver.1.60 and after)	An arbitrary number of files can be bound on the same time axis.
CSV Output	Record the Cursor A-B state displayed in the Waveform Display Window the file in the CSV format. The output results depend on each Waveform Mode (Y-T and FFT).
Print screen	Waveforms can be printed on a printer. To print,the PC must be in a mode that allows printing.
Copy	The displayed screen will be saved as a PNG file.

* Files converted with this software can not be played on the GL devices.

• Convert then save

For recorded files, when there is a split and save between Cursor A-B ,the format can be changed to the CSV format.

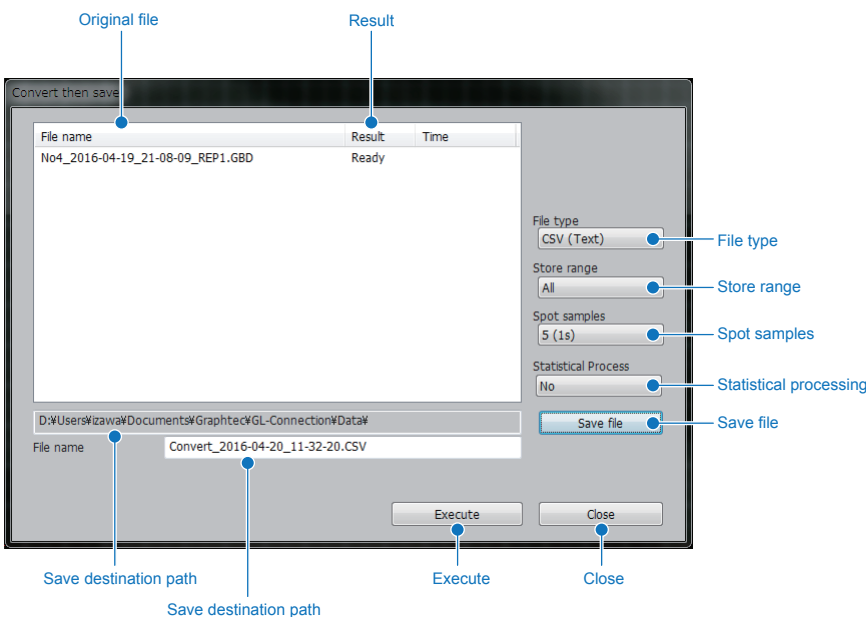

Name	Explanation
------	-------------

Original File	The unchanged file name is displayed.												
Result	The result of the change is displayed. OK: Displayed when the change has been successful. NG: Displayed when the correct change has not taken place												
File type	Select the file format to be changed. GBD (Binary Format): Changes to binary file format. *The data converted form CSV into GBD is usable in only GL7-DCO output file CVS (Text Format): Changes to text format												
Store range	Select the range to save. All: Saves all unchanged files. Cursor Area: Saves the Cursor AB area range.												
Spot samples	Saves the designated sampling points of the original file.												
Statistical processing	If the thinning point is greater than 1, statistical processing can be configured. <table border="1"> <tr> <td>No</td> <td>Statistical processing is not performed.</td> </tr> <tr> <td>Max</td> <td>The maximum value is calculated.</td> </tr> <tr> <td>Min</td> <td>The minimum value is calculated.</td> </tr> <tr> <td>Ave</td> <td>The average value is calculated.</td> </tr> <tr> <td>Peak</td> <td>The peak value is calculated.</td> </tr> <tr> <td>RMS</td> <td>The RMS value is calculated.</td> </tr> </table>	No	Statistical processing is not performed.	Max	The maximum value is calculated.	Min	The minimum value is calculated.	Ave	The average value is calculated.	Peak	The peak value is calculated.	RMS	The RMS value is calculated.
No	Statistical processing is not performed.												
Max	The maximum value is calculated.												
Min	The minimum value is calculated.												
Ave	The average value is calculated.												
Peak	The peak value is calculated.												
RMS	The RMS value is calculated.												
Save file	Sets the save destination for the file.												
Save Destination Path	Displays the save destination path.												
Execute	Saves all changes.												
Close	Closes Save Changes window.												

About Spot Samples

<Spot samples 5 → 1 (10 ms sampling → 50 ms sampling)>

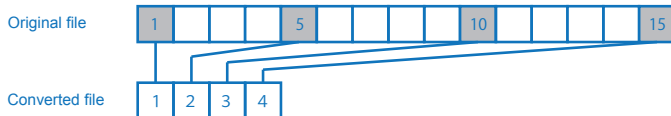

About Statistical processing

<For the average value>

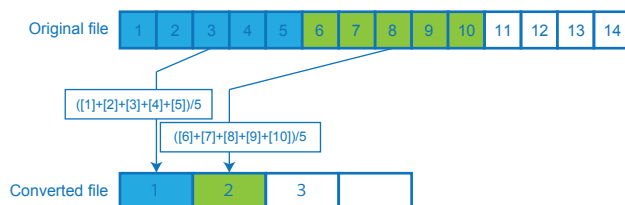

- **CSV file batch conversion**

Changing the formats of multiple GBD (binary) files to CSV (text) format as a batch.

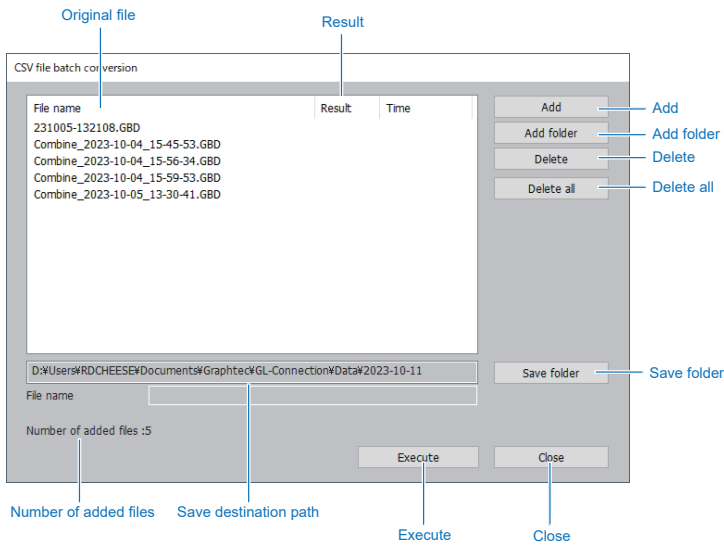

Name	Explanation
Original File	Displays the name of the file being converted.
Result	Displays the result of the processing. OK: Displayed when the processing has been successful. NG: Displayed when the correct processing has not taken place.
Add	Adds a file to the list of files displayed.
Add folder	By specifying a folder, GBD files in the folder are added in batches.
Delete	Deletes a file from the list of files displayed.
Delete all	Deletes all the files displayed in the list.
Save folder	Set the destination.
Number of added files	Displays the number of files currently added
Save destination path	Displays the destination path.
Execute	Executes conversion procedure.
Close	Closes the CSV batch conversion window.

* Up to 10000 files can be converted at once (V2.60 or later).

- **Combine Files**

To connect multiple GBD (binary)files along the temporal axis. The requirement for the recorded files is that this only works for identical files.

- Same Amplifier Modules
- Same channel configuration

File settings like sampling, annotations and user marks settings will follow those of the file at the top of the list.

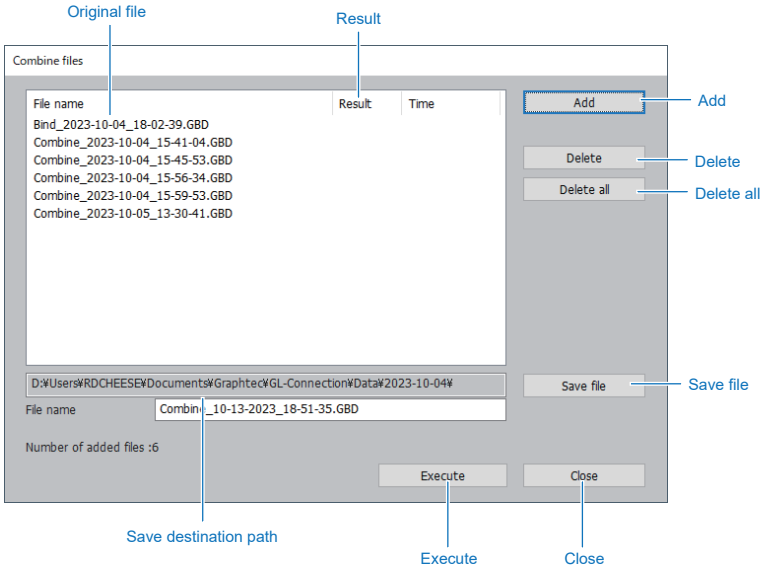

Name	Explanation
Original File	Displays the names of files being connected.
Result	Displays the result of the processing. OK: Displayed when the processing has been successful. NG: Displayed when the correct processing has not taken place.
Add	Adds a file to the list of files displayed.
Delete	Deletes a file from the list of files displayed.
Delete all	Deletes all the files displayed in the list.
Execute	Executes connection procedure.
Close	Close the file connection window.s

* Up to 100 files can be linked at a time.

- **Data bind function (for Ver.1.60 and after)**

A plurality of files on the PC are bound onto the same time axis to make a single file. This function is useful when arranging and comparing different devices.

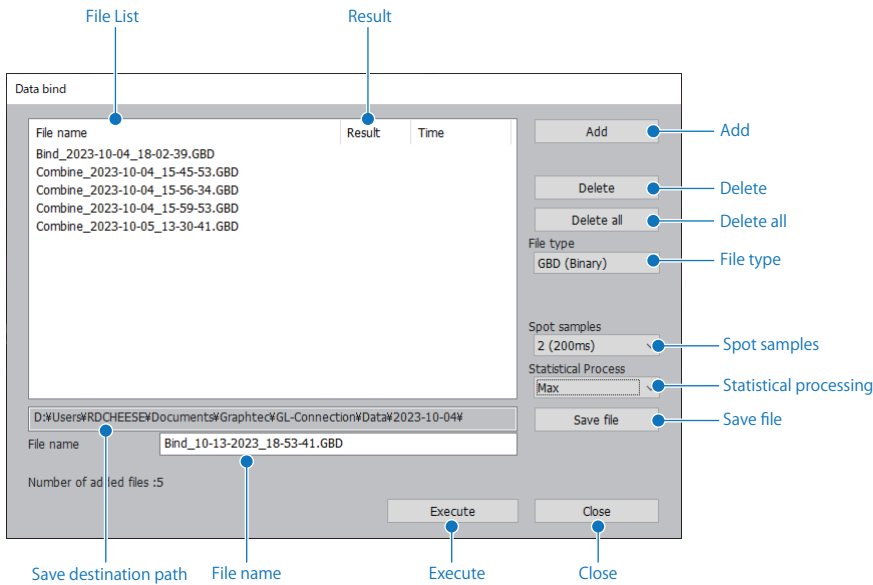

* CHECKPOINT

- * When using files that have different sampling intervals, the default performs binding using the shortest file sampling interval, and therefore, when changing the sampling interval, set to a sampling interval that enables setting to the spot function.
- * Bound data is converted to a GL7000 format.
- * Files are not prepared with the result that the bound file exceeds 100 units, or 1000 channels (analog CH + logic pulse CH).
- * The bound combined files are standardized using information for the file at the top of the file list in the figure below (start time, trigger time, marker information, or the like).

Name	Explanation
File list	A file list to be bound is displayed.
Result	Displays the result of the processing.
Add	Adds a file to the list of files displayed.
Delete	Deletes a file from the list of files displayed.
Delete all	Deletes all the files displayed in the list.
File type	Select the file format to be changed. GBD (Binary Format): Changes to binary file format. *The data converted from CSV into GBD is usable in only GL7-DCO output file CVS (Text Format): Changes to text format
Spot samples	Saves the designated sampling points of the original file.
Statistical processing	If the thinning point is greater than 1, statistical processing can be configured.
Save file	Sets the save destination for the file.
Save Destination Path	Displays the save destination path.
File Name	Sets the file name.
Execute	Binding is executed.
Cancel	Cancels the printing.

* Up to 10 files can be combined at a time.

Operations during binding

<Operations when Starting binding>

1. After making various settings on the data bind window, press "Execute".

<Operations during binding>

A group tab including the files to be bound is automatically prepared, and binding is performed using this tab. Binding is performed in a background configuration and the software operates normally.

Information regarding progress of the binding is displayed on the help window. The tab during binding also changes color.

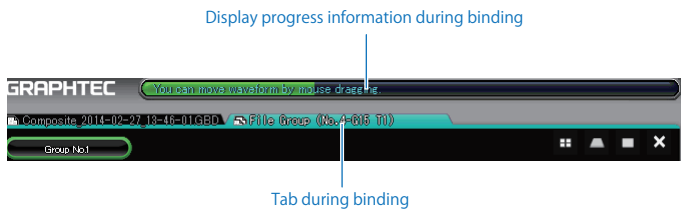

The following operations cannot be performed during binding.

- * Delete tab during binding
- * Add CH to tab during binding
- * Move tab during binding

2. Press save stop button on control panel to stop binding. Press save start button to restart combination.

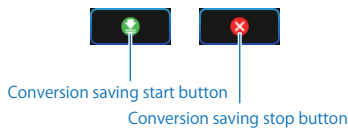

<Operations during binding Completion>

3. When binding is completed, a confirmation message regarding opening of the bound file is displayed.

When the OK button is pressed, playback is performed automatically.

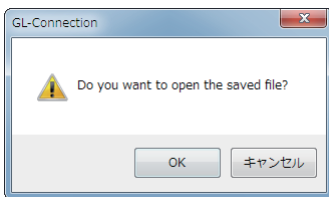

- **CSV Output**

During free running, recording or viewing in Y-T or FFT Waveform Mode, the displayed data is output to the file in CSV format. In X-Y Mode, the CSV output is not available.

Y-T Waveform Mode

During free running or recording:

- Vendor, model, version, date
- Cursor time
- CH settings (Input, range, filter, scaling, sampling interval)
- Instantaneous value

During viewing:

- Vendor, model, version, date
- Cursor time
- CH settings (Input, range, filter, scaling, sampling interval)
- Levels on cursor A and cursor B
- Calculated statistical values between the cursor A and B (Maximum value, minimum value, average value, peak value, effective value)

FFT Waveform Mode

During free running, recording or viewing:

- Vendor, model, version, date
- FFT settings (Analysis frequency, Number of analysis points, Window function, Averaging mode, CH setting)
- Overall
- Peak list (Up to 10)
- All data (Data for the number of analysis points)

• **Print Screen**

To print the screen displayed or waveform data using a printer. To print, the PC must be in a mode that allows printing.

The printing process will occur according to the sequence as follows.

(1) Print window[OK] → (2) Window standard print screen [OK] → (3) Multi-page printing confirmation → (4) Print

Print window

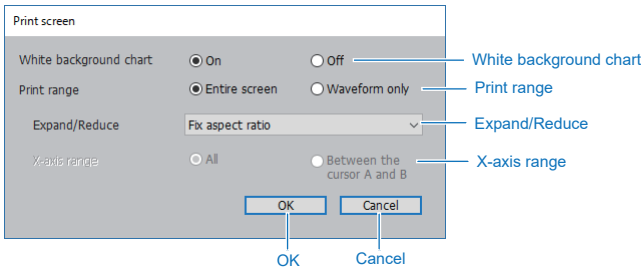

Name	Explanation	
White background chart	Switch on to print the waveform window and digital monitor window with a white background.	
Print range	Entire screen	To print everything that is displayed on the screen. Select this to print everything that you see on the screen.
	Waveform only	Can only print the waveform window during data playback. Everything including the scroll bar in the waveform window will be printed.
Expand/Reduce	Will be effective when the print range is set to full screen.	
	Fix aspect ratio	Fit to printing paper when maintaining the aspect ratio.
	Fit to vertical width of print sheet	Print by fitting the vertical range of the print screen to that of the printing paper.
	Fit to horizontal width of print sheet	Print by fitting the horizontal range of the print screen to that of the printing paper.
	Fit to the print sheet	Print by fitting to the print paper, ignoring the aspect ratio of the print screen.
X axis range	Effective when the print range is set to waveform only.	
	All	Print all the time axis data during data playback. Before printing is initiated, it is possible to choose to print multiple pages by moving the cursor to the place in between A-B or by adjusting the Time/DIV of the wave display.
	Between Cursor A and B	Print the waveform in between cursor A-B during data playback.
OK	Completes the print window settings and displays the Window standard print screen.	
Cancel	Cancels the printing.	

Windows standard print screen

Displays the standard Windows print screen. Choose the printer to be used here. As the properties of printers differ, please refer to individual printer’s user’s manual.

When done with setting, press the OK button.

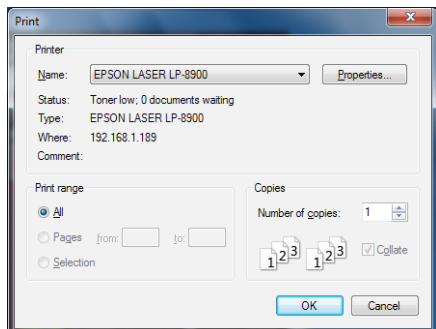

Multi-page printing confirmation

The number of pages to be printed will be calculated according to the Print Window Settings and setting in Windows Standard Print Screen. If the number of prints are not suitable, please adjust by changing the setting in Time/DIV or reviewing the settings.

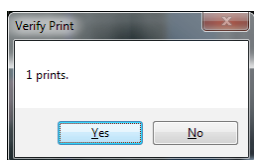

• **Copy**

Saves the screen being displayed in the PNG file format.

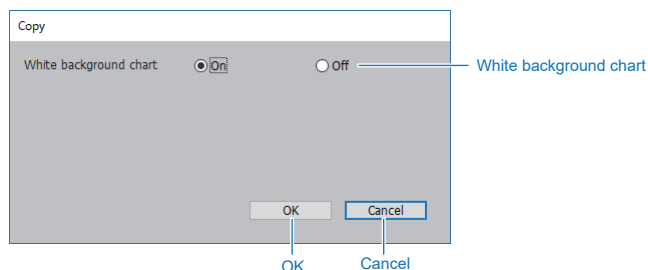

Name	Explanation
White background chart	Switch on to print the waveform window and digital monitor window with a white background.
OK	Completes the settings of the window and transitions to the Save File Window.
Cancel	Cancels the process.

11-12-5. **Action**

The operations for the waveform and data depend on the each mode (Y-T, X-Y and FFT). Refer to the chapter of each wave mode.

11-12-6. **Option**

Changes to option related panel. For details on the option panel, please refer to “10-7-6. Option Settings”

11-12-7. Recording Start/Stop

To start/stop recording. You can only perform starting and stopping from the Device Tab.



Start record button



Stop record button

To check if recording has failed, perform the following steps.

- Check if the main module recording destination is correct (for example, even though an SD card is not inserted, recording destination is set as the SD card.)
- Check if PC recording destination is correct (for example, check settings have not been made to non-existent disk and pass)
- Check that the sampling value is suitable (for example, module configuration and format (GBD/CSV) etc.)
- Check the available disk space in the main module recording destination medium (Recording cannot start if the disk is full)
- Check the device tab (Recording cannot start at replay tabs, group tabs, demo etc.)
- Check that trigger conditions are correct (Recording cannot start with incorrect trigger conditions)
- Check that the main module is turned on
- Check that this application is running

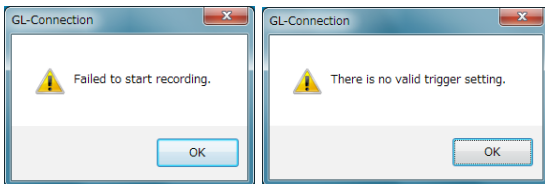

11-12-8. Conversion saving start/conversion saving stop



Conversion saving start button

Conversion saving stop button

Various types of conversion saving start/conversion saving stop are performed when playback tab is active. Operations when pressing buttons depend on type of playback tab.

Active tab	Operations for conversion saving start button	Operations for conversion saving stop button
PC file playback	Conversion saving playback	No operation since processing is completed on conversion saving window
Device file playback	Conversion saving playback	No operation since processing is completed on conversion saving window
Group playback	Data bind operation	Stop data bind

Refer to "Convert then save" for conversion saving operation.

Refer to "Data bind function (for Ver.1.60 and after)" for data bind operation.

12. Y-T Waveform Mode

The input signal level is displayed on the Y axis, and time is displayed on the X axis of this graph.

12-1. Waveform Window

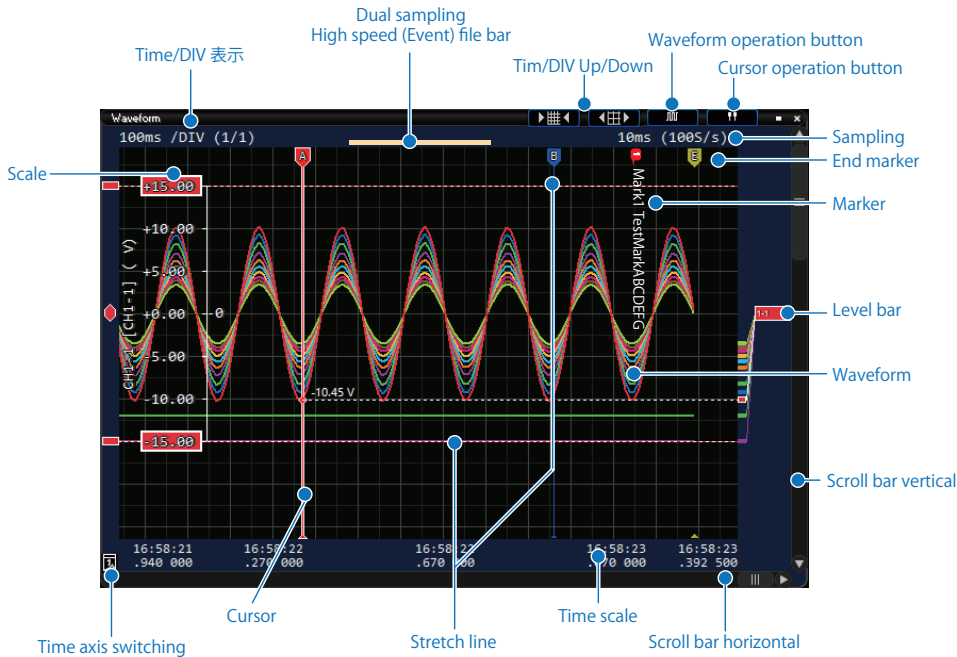

Name	Explanation
Waveform operation button	Functions in regard to waveform operation are aggregated.
Cursor operation button	Functions in regard to the cursor are aggregated.
Time/DIV Up/Down	Change the Time/DIV value to expand or contract the waveform.
Time/DIV	Display the Time/DIV value of the displayed waveform. Time/DIV represents the time in one grid width. When 1sec/DIV is set, the one grid width is 1 sec. The currently used compressed file is displayed during viewing. <ul style="list-style-type: none"> • 1/1 Currently recorded file • 1/10: 1/10 compressed file • 1/100 : 1/100 compressed file • 1/10000: 1/10000 compressed file For information on the compressing function, refer to 16-1. Data Compressing Function
Sampling	Displays the value of sampling from a connected device, or the sampling of a file that is being played back.
Waveform	Displays the waveform.
Scale	The stretch line displays the channel set to active in the monitor window. The stretch line's upper value is found in the Span Setting's upper value, while the stretch line's lower value is found in the Span Setting's lower value.
Stretch line	The stretch line displays the channel set to active in the monitor window. The stretch line's upper value is found in the Span Setting's upper value, while the stretch line's lower value is found in the Span Setting's lower value
Level bar	Displays each channel's signal position. If the level bar is dragged with the mouse, the upper and lower values of the waveform can be changed.
Time scale	The X axis displays time. The displayed information is changed to match the Time/DIV setting.
Cursor	While data is being played back the cursor is displayed, and above the cursor you can see the time frame, signal level, etc. There is an A cursor, and B cursor, and they can be moved left or right by dragging with the mouse.

End marker	Display waveform data end.
Marker	During Recording you can record a mark in the waveform display information. Marks set after an alarm goes are called alarm marks, while marks depicting arbitrary characters are called user marks. There are 8 marks.
Scroll bar horizontal	If you drag the scroll bar with the mouse during data playback, you can move the time axis.
Scroll bar vertical	If you drag with the mouse, you can move the upper and lower area of the waveform display area.
Time axis switching	Switching is performed in absolute time, relative time and point display.
Dual sampling / Event (high-speed) file progress bar	Displays a progress bar showing the event (high-speed) file recording position during playback of the current (low-speed) file recorded using the dual sampling function.

12-1-1. Waveform operation button

You can operate waveforms when Y - T waveform is displayed.

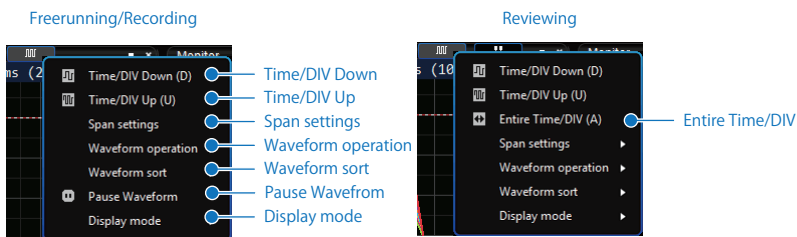

Name	Explanation
Time/DIV Down	Reduce the Time/DIV setpoint, and display the reduced waveform.
Time/DIV Up	Raise the Time/DIV set point, and display the expanded waveform.
Entire Time/DIV	Calculate and change to the optimal Time/DIV to display the complete length of the waveform. Only available during playback.
Span settings	Expands/reduces and moves the span of the active channel.
Waveform operation	Expands/reduces and moves the waveform display of the active channel.
Waveform sort	Sorts the display position of the waveform.
Pause Waveform	Pauses the scrolling waveform. This does not affect data recording. Only available while free-running and recording.
Display mode	Switch waveform mode.

• Time/DIV (Waveform) operation

Operates the active tab waveform window's Time/DIV.

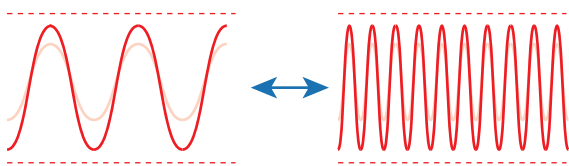

Time/DIV operation during free-running or recording

- Changes the newly scrolled through waveforms.

Time/DIV operation during data playback

- When cursor A,B is displayed on the screen
Changes the Time/DIV around the active cursor.
- When cursor A,B is displayed on the display
The Time/DIV around the center of the screen will be changed.

- **Span operation**

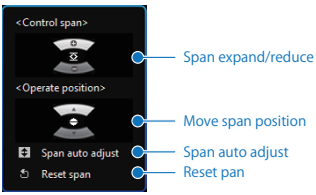

Span expand/reduce

Expands/reduces the span of the active channel. Changes $\pm 10\%$ of the full scale amount.

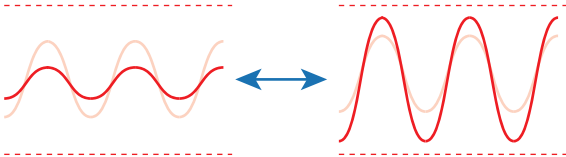

Move span position

Moves the position of the active channel. Changes $\pm 10\%$ of the full scale amount.

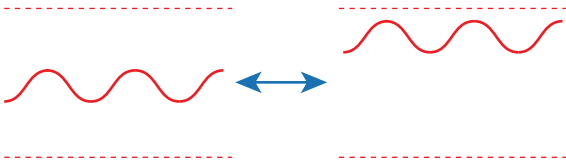

Span auto adjust

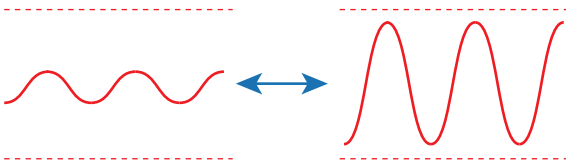

Reset Span

Changes the span of the active channel back to default.

Voltage: $\pm 1/2$ of the full scale

Temperature: from 2000° C to -200° C

- **Waveform operation**

Stretch expand/reduce

Expands/reduces the waveform amplitude of the active channel. The expansion/reduction of the waveform will only change the amplitude and not the span value. 1 grid/2 module will be changed.

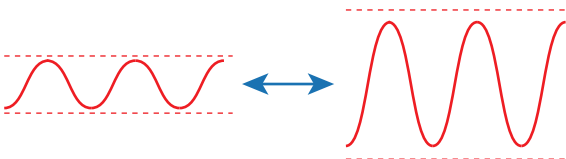

Move waveform position

Up/down movement of the waveform Moves the waveform of the active channel up/down. The up/down movement of the waveform will only change the position of the waveform and not its span value. 1 grid/2 module will be changed.

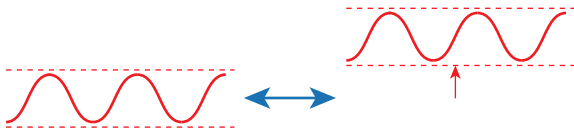

Waveform sort

Changes the position of the waveform. The 3 modes will change in order. Please note that arranging the waveform will clear the settings of waveform expansion/reduction and up/down movement of the waveform.

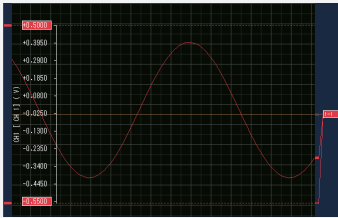
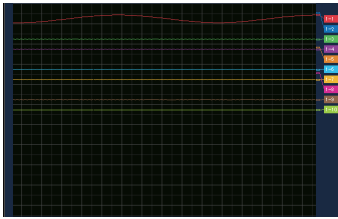
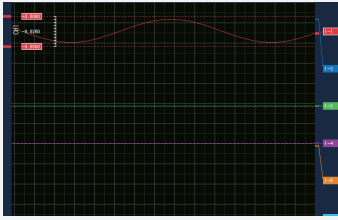
<p>Display everything on display window</p>	<p>Set to display everything on the waveform field.</p> 
<p>Equal split of full window</p>	<p>Set to equally split individual channels of the full waveform window. If the number of channels does not allow equal splitting, they will appear stacked.</p> 
<p>Equal split of display window</p>	<p>Set to equally split individual channels of the displayed waveform field. If the number of channels does not allow equal splitting, they will appear stacked.</p> 

12-1-2. Cursor Opeartion button

Used to perform operations related to the cursor while displaying the Y-T waveform.

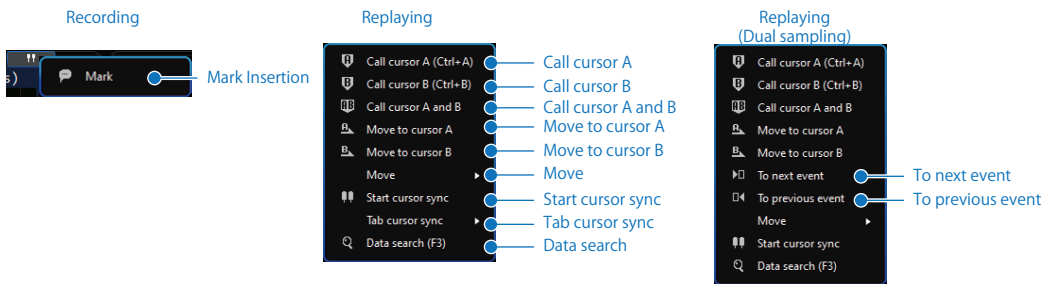

Name	Explanation						
Mark Insertion	Inputs a mark.						
Call cursor A, Call cursor B	Call cursor A or cursor B to the waveform displayed.						
Call cursor A and B	"Call cursor A and B" calls both cursors A and B.						
Move to cursor A, Move to cursor B	To move the position of cursor A or cursor B in the waveform displayed.						
Move	Perform each move operation.						
Start cursor sync	To move cursor A and cursor B in synchronization with each other.						
Tab cursor sync (version 2.20 or later)	The cursors on multiple file tabs can be moved synchronously. <table border="1" style="width: 100%; border-collapse: collapse;"> <tr> <td>Off</td> <td>Cursors are not synchronized.</td> </tr> <tr> <td>Time from the beginning</td> <td>Synchronizes the time from the beginning.</td> </tr> <tr> <td>Position from present</td> <td>Synchronization using the cursor position when this setting was enabled as the starting point.</td> </tr> </table>	Off	Cursors are not synchronized.	Time from the beginning	Synchronizes the time from the beginning.	Position from present	Synchronization using the cursor position when this setting was enabled as the starting point.
Off	Cursors are not synchronized.						
Time from the beginning	Synchronizes the time from the beginning.						
Position from present	Synchronization using the cursor position when this setting was enabled as the starting point.						
Data search	By combining the four main requirements, search/move data in various ways. The search starts at the position of the selected cursor and the cursor will be moved to a new position that satisfies the requirements of the search/move. Only available during playback.						
To next event (version 2.20 or later)	Switches to the next event file during playback of the dual sampling file.						
To previous event (version 2.20 or later)	Switches to the previous event file during playback of the dual sampling file.						

• Mark Insertion

To insert mark while recording. (* GL7000 only)

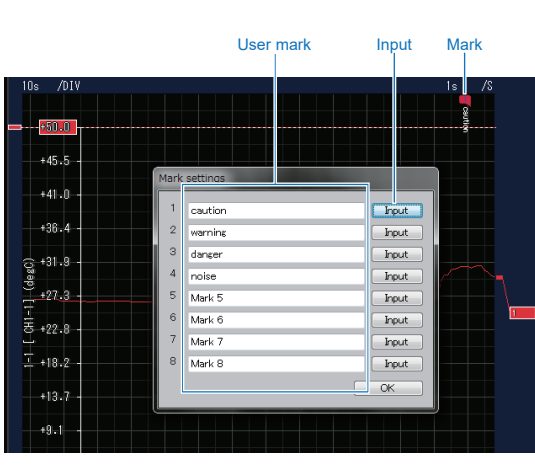

Name	Explanation
User mark	Able to change the user mark character even while recording. However only the last character output will be remembered in the data file.
Input	When the input button is pressed, a scroll will appear on the right side of the Y-T waveform. A mark will appear at the same position during data replay.

• Call cursor A, Call cursor B

Call cursor A or cursor B to the waveform displayed. Cursor A will appear at the place 1/4 from the left of the, screen cursor B will appear at the place 3/4 from the right of the

screen. Only available during playback.

- **Move to cursor A, Move to cursor B**

To move the position of cursor A or cursor B in the waveform displayed. Only available during playback.

- **Move**

Perform each move operation.

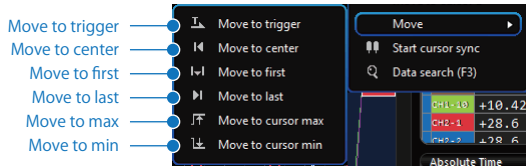

Name	Explanation
Move to trigger	To move the position of the start trigger in the waveform displayed. Only available during playback.
Move to center	To move the position of the center in the waveform displayed. Only available during playback.
Move to first	To move the position of the first in the waveform displayed. Only available during playback.
Move to last	To move the position of the last in the waveform displayed. Only available during playback.
Move to max	To move the position of the max in the waveform displayed. Only available during playback.
Move to min	To move the position of the min in the waveform displayed. Only available during playback.

- **Start cursor sync**

To move cursor A and cursor B in synchronization with each other. Only available during playback.

- **Tab cursor sync**

The cursors on multiple file tabs move synchronously.

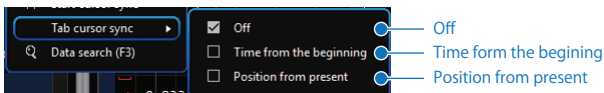

If the time from the beginning is selected, each cursor moves to the position so that the time from the beginning is the same value. Since the calculated time takes the sampling interval into account for movement, even files with different sampling intervals can be synchronously moved with the same time interval.

If the position from present is selected, they move synchronously in the same time interval taking the cursor position at the time of selection as the starting point.

It is also possible to use the time from the beginning and the position from present settings in combination to move from the starting point for each beginning time or present position.

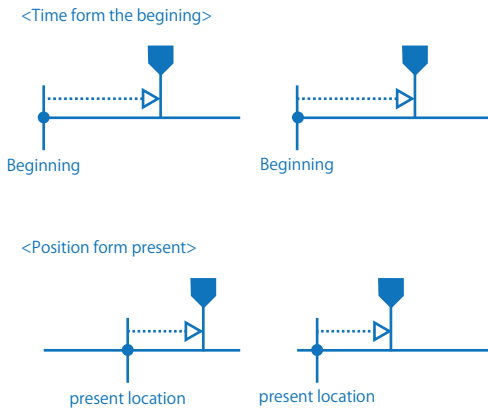

• **Data search/move**

By combining the four main requirements, search/move data in various ways. The search starts at the position of the selected cursor and the cursor will be moved to a new position that satisfies the requirements of the search/move. This function will only be effective during playback.

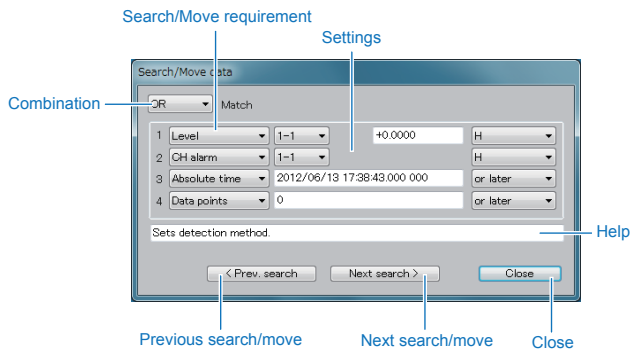

Name	Explanation	
Combination	OR	Effective when either one of the effective search/move requirements is satisfied.
	AND	Effective when all of the effective search/move requirements are satisfied.
Search/move requirements	Off	Makes the search/move requirements ineffective.
	Level	Search using the level values of analog data, logic data or pulse data.
	CH alarm	Search using the alarm generation of each channel in the analog data, logic data or pulse data.
	Alarm output	Search using the alarm output.
	Absolute time	Search using absolute time.
	Relative time	Search using relative time.
	Data Points	Search using data Points.
Mark	Search using mark. (*GL7000 only)	
Previous search/move	Search/move the within the previous range with the cursor selected.	
Next search/move	Search/move the within the following range with the cursor selected.	
Close	Closes the search/move window.	
Help	Explains the contents of each item in the setting.	

When the search/move requirements are level

<In the case of analog/pulse>

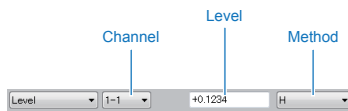

Name	Explanation
Channel	To set the channel code used in search.
Level	To set the level used in search.
Method	H: Detects when the set level value is exceeded from below the set level value. L: Detects when the set level value falls under from over the set level value. or more: Detects in the range higher than the set level. or less: Detects in the range lower than the set level.

<In the case of logic>



Name	Explanation
Select bit	To set the channel code used in search.
Method	H: Detects when the set bit is changed from L to H. L: Detects when the set bit is changed from H to L. HL: Detects when the set bit is changed from L to H or from H to L.

When the search/move requirements are CH alarm

<In the case of analog pulse>

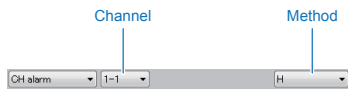

<In the case of logic>

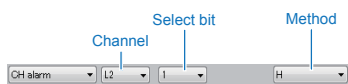

Name	Explanation
Channel	To set the channel code used in search.
Select bit	To set the channel code used in search.
Method	H: Detects when the set bit is changed from L to H. L: Detects when the set bit is changed from H to L. HL: Detects when the set bit is changed from L to H or from H to L.

When the search/move requirements are alarm output

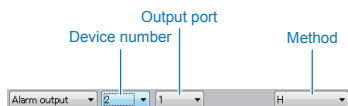

Name	Explanation
Device number	To select the device number. The device number is the number written on the tab of the device. In the case of multiple devices with group tabs, please select one device.
Output port	To select the alarm output port.
Method	H: Detects when the set bit is changed from L to H. L: Detects when the set bit is changed from H to L. HL: Detects when the set bit is changed from L to H or from H to L.

When the search/move requirements are absolute time, relative time, data points

The screenshot shows a search criteria configuration interface with four main sections:

- Absolute time:** A dropdown menu set to 'Absolute time' with a text input field containing '2012/06/13 17:38:43.000 000' and a 'or later' dropdown.
- Relative time:** A dropdown menu set to 'Relative time' with a text input field containing '0000:00:00.000 000' and a 'or later' dropdown.
- Data points:** A dropdown menu set to 'Data points' with a text input field containing '0' and a 'or later' dropdown.
- Method:** A dropdown menu set to 'Method' with a 'or later' dropdown.

 Blue arrows point from labels above to the respective dropdown menus.

Name	Explanation
Absolute time	To set to absolute time.
Relative time	To set relative time from the start of the recording.
Data points	To set to data points.
Method	After: To detect the results that are after the search requirements. Before: To detect the results that before the search requirements.

It is convenient to use a combination of absolute time, relative time and data points.

For example) Everything is consistent

Search requirement 1: After 1st of October 2012

Search requirement 2: CH1-1 level 0.5V H

Detail of search: Search results that are after 1st of October 2012 and CH1-1 is higher than 0.5V.

When the search requirements are marks

The screenshot shows a search criteria configuration interface with three main sections:

- Mark:** A dropdown menu set to 'Mark' with a text input field containing 'User mark1' and a 'Match' dropdown.
- Select mark:** A dropdown menu set to 'Select mark'.
- Method:** A dropdown menu set to 'Method'.

 Blue arrows point from labels above to the respective dropdown menus.

Name	Explanation
Select mark	To select the type of marks.
Method	Consistence: Register results where the set mark types are consistent.

12-1-3. Scale Display

Displays the scale of the channel set to active in the monitor window.

- **Leaving a Scale**

If you break the button the leave the scale in the monitor window, you can view several scales at once.

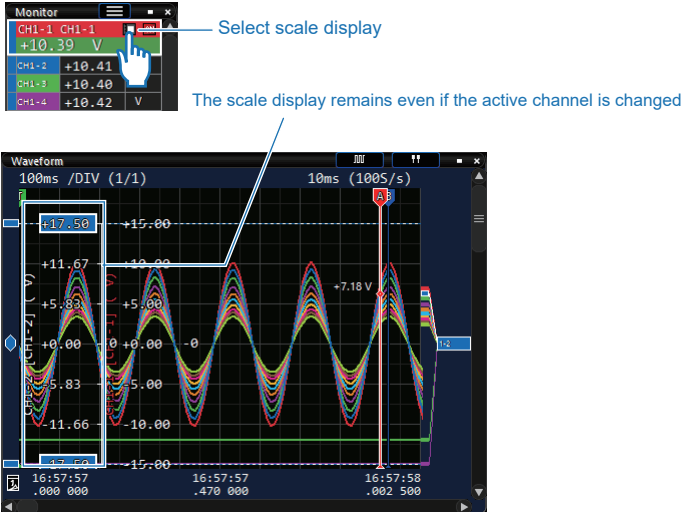

- **Scale Value Entry**

If you click the boxes you can directly enter values. After you are finished entering the values, press the enter key to confirm.

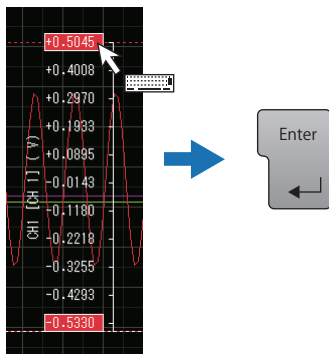

- **Move Scale Position**

The position of the scale can be changed by dragging it with the mouse.

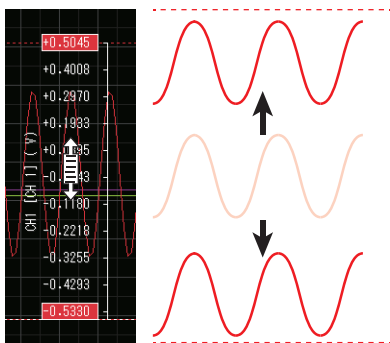

- **Span Zoom In/Out**

When the mouse is above the scale, the mouse wheel can be used to zoom in or out of the span. (For situations where there is no mouse wheel, you can perform the same operations from the waveform section of the Control Panel).

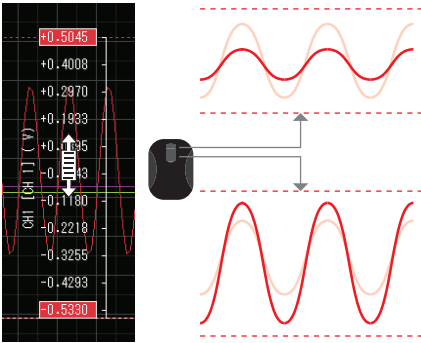

- **Stretch Line Zoom In/Out**

By dragging the stretch line up and down with the mouse, the upper and lower limits of the waveform can be changed. Holding down the Shift key while dragging the stretch line up and down with the mouse, it is possible to change the upper and lower limits of the display width at the same time.

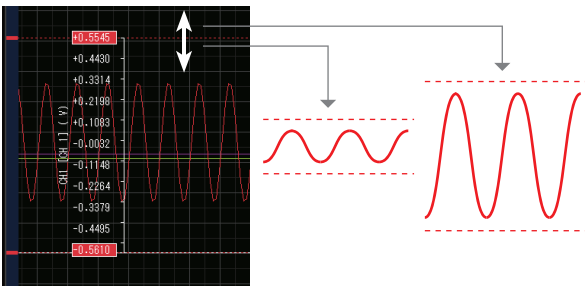

- **Span Slider Control**

The span can be changed by dragging the span slider on the left side of the stretch line up or down with the mouse. (Span slider is then drawn in nearby grid.)

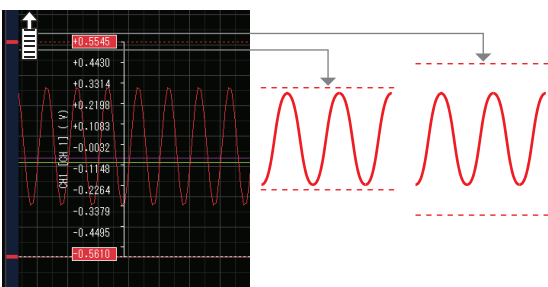

- **Auto span adjustment**

This is a function to adjust the span value after the suitable display width is derived from the waveform signal currently displayed.

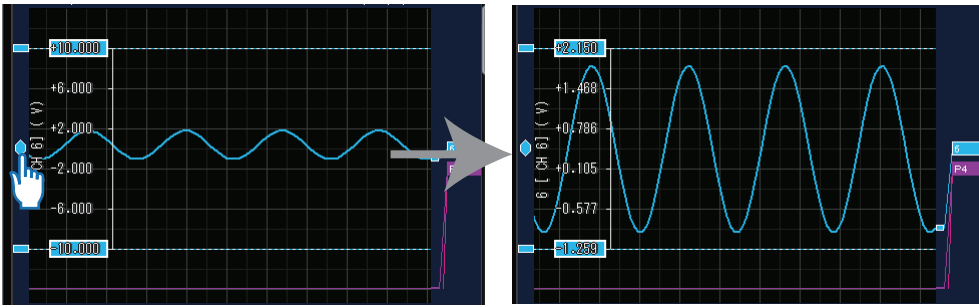

12-1-4. Level bar display

Displays all CH signal value.

- **Level Bar Operation**

Displays all CH signal value. If the level bar is dragged with the mouse, the upper and lower values of the waveform can be changed.

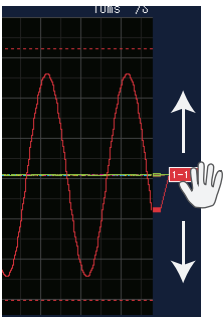

Waveform

Waveform operations and cursor operations can be easily performed by right-clicking in the waveform display area. Refer to the sections on the waveform operation button and the cursor operation button for details on the operation of each item.

During free-running / recording

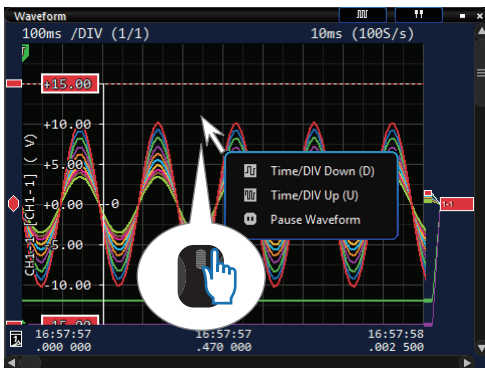

During playback

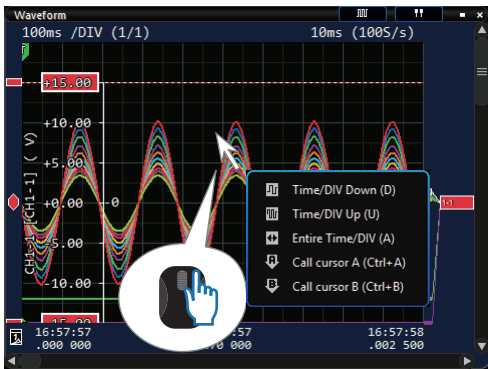

12-1-5. Time Scale Display Contents

The X axis displays time. The displayed information is changed to match the Time/DIV setting.

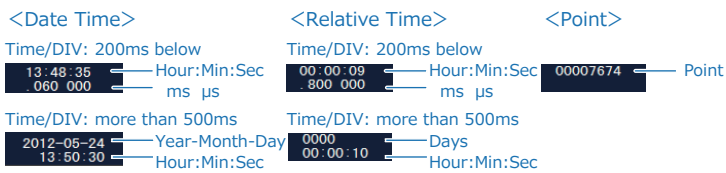

12-1-6. Cursor Display

While data is being played back the cursor is displayed, and above the cursor you can see the time frame, signal level, etc. There is an A cursor, and B cursor, and they can be moved left or right by dragging with the mouse.

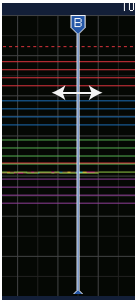

12-1-7. Mark Display

During Recording you can record a mark in the waveform display information. Marks set after an alarm goes are called alarm marks, while marks depicting arbitrary characters are called user marks. There are 8 marks. For information on entering a mark, please refer to 15-7. Marker Settings

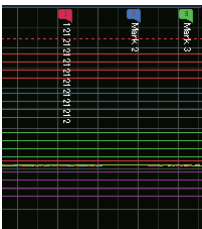

* You cannot change the position of a mark once it's been entered

12-1-8. Scroll Bar Horizontal

If you drag the scroll bar with the mouse during data playback, you can move the time axis.

12-1-9. Scroll Bar Vertical

If you drag with the mouse, you can move the upper and lower area of the waveform display area.

12-1-10. Switch Time Display

Switches between the absolute time, relative time, and point display.



12-2. Time Line Window

You can use the Y-T wave form window to view everything. The digital monitor allows 1 channel's wave form to be displayed.

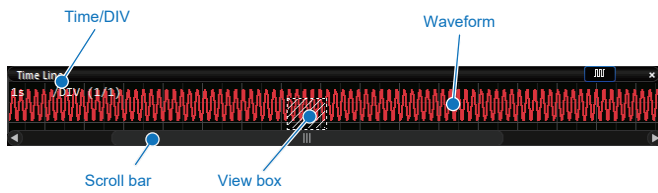

Name	Explanation
Time/DIV	Display the Time/DIV value of the currently displayed waveform. Time/DIV displays time to one 1 grid axis. For 1sec/DIV1 grid's display axis is 1 second.
Waveform	Displays the waveform. The active channel's wave form is displayed on the digital monitor.
View box	Displays the display area of the Waveform Display Window. The wave form display windows display value can be changed by dragging it with the mouse. <div data-bbox="571 801 1117 1169" data-label="Image"> <p>This inset image shows a zoomed-in view of the waveform. The top part shows a 'Waveform' window with a grid and multiple colored waveforms. A red dashed box highlights a portion of the waveform. Below it, the 'Time Line' window is shown with a red waveform and a dashed box highlighting a specific time interval. Arrows indicate the relationship between the view box in the main window and the zoomed-in view.</p> </div>
Scroll bar	If you drag the scroll bar with the mouse during data playback, you can move the time axis.

12-3. Monitor Window

This window displays the signal's level value. During free running or recording, new information is updated every 0.5 seconds. During playback, selecting either cursor A or B will display the signal level value of the chosen cursor. Depending on the window size, all modes (Digital, Statistical Calculation, Expanded Digital) can be used.

12-3-1. Digital Display

This display mode shows wave form displays lined up with each other.

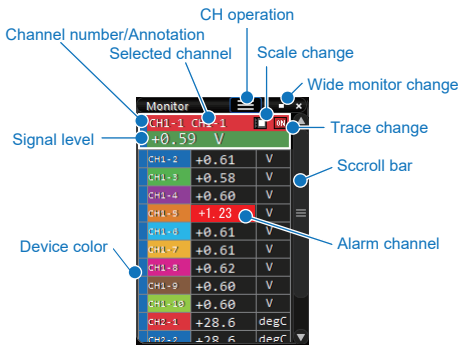

Name	Explanation						
Channel number	The displayed channel's number and wave form color are displayed. The channel number is [module Number]-[Channel Number]. Analog channel: CH1-5 Pulse channel: P3-12 Logic channel: L2 (Module number only is displayed for the logic channel)						
Selected channel	From the selected channel, you can view the next item, or operate it. By pressing the keyboard's Shift key or Ctrl key and clicking the mouse at the same time, multiple channels can be selected at once. The background of the selected channel changes to green. <table border="1" data-bbox="571 1200 1302 1424"> <tr> <td>Waveform Window</td> <td>Display in front Scale Display Stretch Line Display</td> </tr> <tr> <td>Time Line Window</td> <td>Waveform Display</td> </tr> <tr> <td>Monitor Window</td> <td>Scale Change Trace Change Group Creation</td> </tr> </table>	Waveform Window	Display in front Scale Display Stretch Line Display	Time Line Window	Waveform Display	Monitor Window	Scale Change Trace Change Group Creation
Waveform Window	Display in front Scale Display Stretch Line Display						
Time Line Window	Waveform Display						
Monitor Window	Scale Change Trace Change Group Creation						
Digital values	Displays signal level during free running, recording, or reviewing. <table border="1" data-bbox="571 1458 1302 1619"> <tr> <td>Free-running, Recording</td> <td>Displays the newest entered signal level from a device. It is refreshed every 0.5 seconds.</td> </tr> <tr> <td>Reviewing</td> <td>Selecting either cursor A or B will display the signal level value of the chosen cursor.</td> </tr> </table>	Free-running, Recording	Displays the newest entered signal level from a device. It is refreshed every 0.5 seconds.	Reviewing	Selecting either cursor A or B will display the signal level value of the chosen cursor.		
Free-running, Recording	Displays the newest entered signal level from a device. It is refreshed every 0.5 seconds.						
Reviewing	Selecting either cursor A or B will display the signal level value of the chosen cursor.						

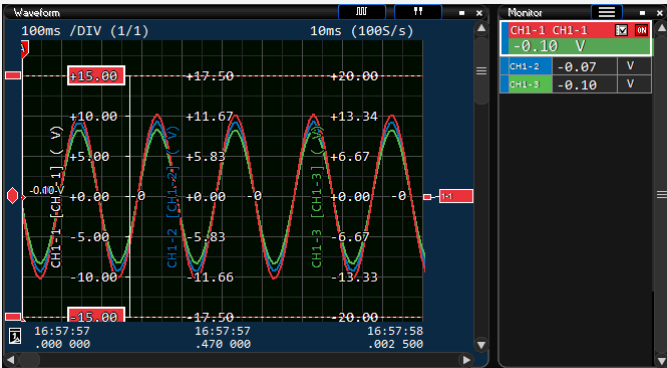
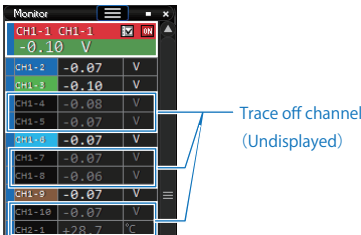
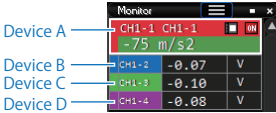
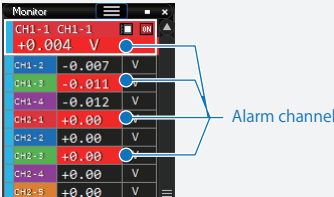
<p>Scale change</p>	<p>Pressing the scale button will leave the scale display in the waveform window. You can display the scale of all channels where the scale button has been pushed.</p> 
<p>Trace change</p>	<p>Pressing the trace button allows the chosen channel's wave forms to be displayed. Even if it not being displayed, there is no effect on the recording data. Double-clicking on a channel allows you to switch traces.</p> 
<p>Wide mode change</p>	<p>Changes the display mode to the wide mode.</p>
<p>Select all CH</p>	<p>Select all the channels.</p>
<p>Scroll bar</p>	<p>The channel display can be moved by dragging it up or down with the mouse.</p>
<p>Device color</p>	<p>Connected devices and files being played are automatically assigned colors as device colors. In the event assigned device colors become mixed in monitor windows according to group function, it is possible to view which device the signal belongs to. For information on group functions, refer to 16-2. Group functions</p> 
<p>Alarm channel</p>	<p>Channels where an alarm has gone off will be Displayed with a red background.</p> 

• CH Operation

Used to perform CH operations related to the Monitor Window.



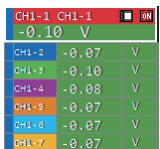

Select All CH

Select all the channels.



Filter

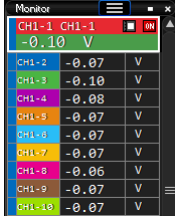
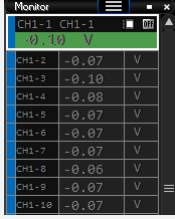

Name	Explanation
Trace On channel only filter display	<p>Extracts and displays only the Trace On channels. All the other channels will not be displayed. Even though they are not displayed, the recorded data will not be affected.</p> 
Trace Off channel only filter display	<p>Extracts and displays only the Trace Off channels. All the other channels will not be displayed. Even though they are not displayed, the recorded data will not be affected.</p> 
Alarm generating channel only filter display	<p>Extracts and displays only the alarm generating channels. All the other channels will not be displayed. The filter description will not change even though the channel's alarm status has been changed. Even though they are not displayed, the recorded data will not be affected.</p> 
Filter display reset	<p>Resets filter status like TraceOn, traceOff, alarm generation to their default setting.</p>

Switch Screen

Switches the screen mode.



12-3-2. Statistics calculation display

A wide-width display mode that hides the waveform display. You can switch to the Statistical Calculation Screen by pressing the Maximize button from the Digital Screen display.

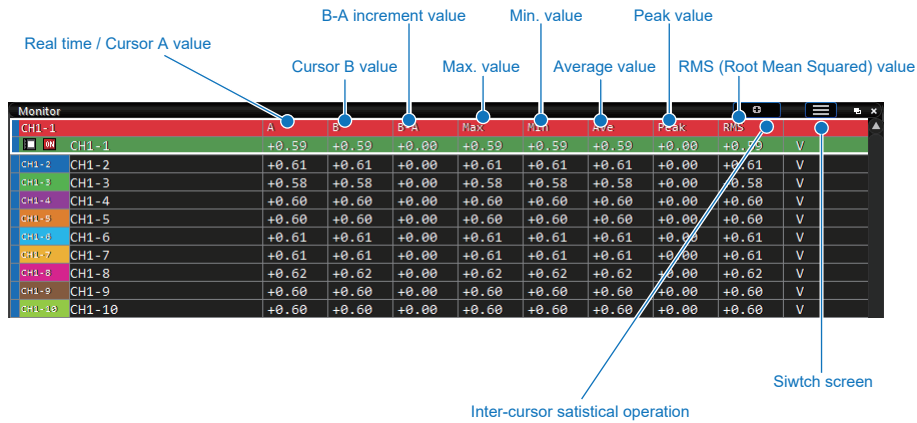

Name	Explanation
Real time /Cursor A value	Displays the newest real time signal level value from free running or recording in progress. Signal level is displayed above cursor A during playback.
Cursor B value	Signal level is displayed above cursor A during playback.
B-A increment value	Displays Cursor B and Cursor A's increment value during playback.
Max. value	Show the Maximum Value, Minimum Value, Average Value, Peak to Peak Value during free running, recording, or reviewing.
Min. value	
Average value	
Peak value	
RMS (Root Mean Squared) value	Performs statistics operation for the area between cursors in playback, and displays root mean squared value.
Inter-cursor statistical operation	Performs the statistics operation for the area between Cursor A and Cursor B during statistics operation playback for cursor area.
Switch Screen	Switch Screen.

12-3-3. Expanding Digital Display

You can increase the size of the characters during wide display mode.

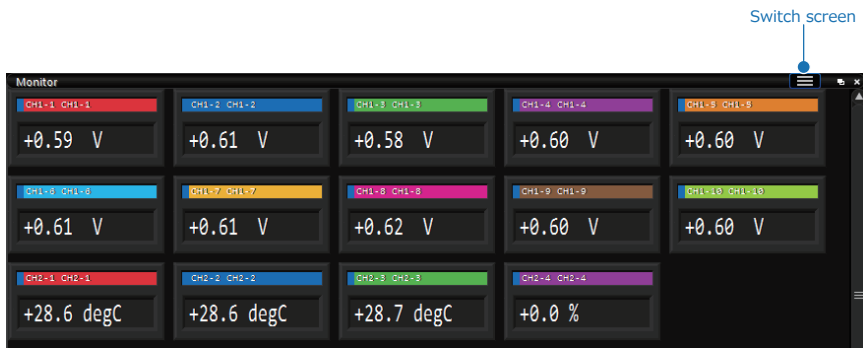

Name	Explanation
Switch column	Toggles the number of CHs displayed per line. 5: Displays up to 5 channels per line. 10: Displays up to 10 channels per line.
Switch screen	Switches the screen.

12-4. Y-T Waveform Control Panel

12-4-1. Main Panel

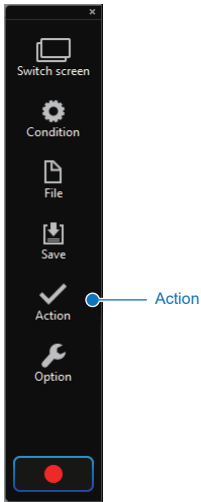

Name	Explanation
Action	Changes to action related panel.

12-4-2. Action

Changes to panel related to action. Depending on free-running, recording and replaying, the different panel contents are displayed.

- During free-running and recording



Name	Explanation
Clear pulse	When the pulse input the logic pulse module is set for the accumulation, the accumulated data is cleared to 0 (zero). You can set it during free-running or recording.
Adjust all autobalance	Displayed when the strain unit is connected. Opens the batch auto balance adjustment screen.(GL-Connection Ver. 2.20 or later)
Voltage output module start / stop	When the Voltage Output Module (GL7-DCO) for GL7000 is installed and the data has been loaded already to the Voltage Output Module, the start or stop of the signal output can be controlled.

Clear pulse accumulation

To clear the pulse accumulation value. The value will also be automatically cleared when the recording starts.

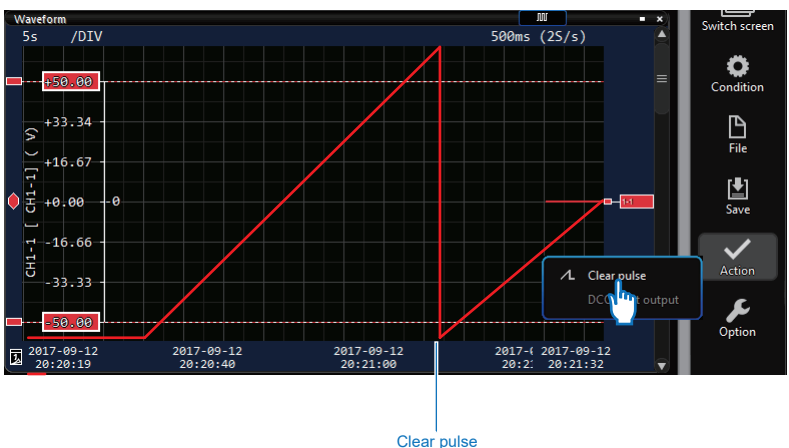

- **During reviewing**



Name	Explanation
Checksum verification (Ver.2.30 or later)	Check the checksum of the GBD file.

Checksum verification (Ver. 2.30 or later)

The checksum is added to the GBD file recorded by the device with firmware version 2.30 or later. The checksum is used to verify that the saved file is not falsified.

Verifying checksum

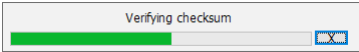

Press the [X] button to cancel.

When checksums match

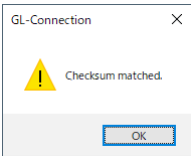

When checksums mismatch

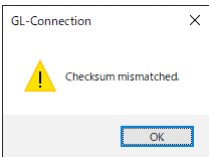

When the file is not supported

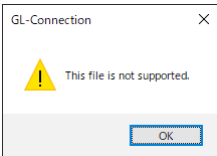

* Note

It may take time to do a sum if the number of data is large.

13. X-Y Waveform Mode

13-1. Waveform Window

After assigning the input signal to the X axis and the Y axis, the X and Y 's signal can correlatively be displayed with wave form display. The X-Y waveform can at maximum show 4 channels. The X-Y waveform can only be displayed during free running and during recording. During playback the X-Y waveform cannot be displayed.

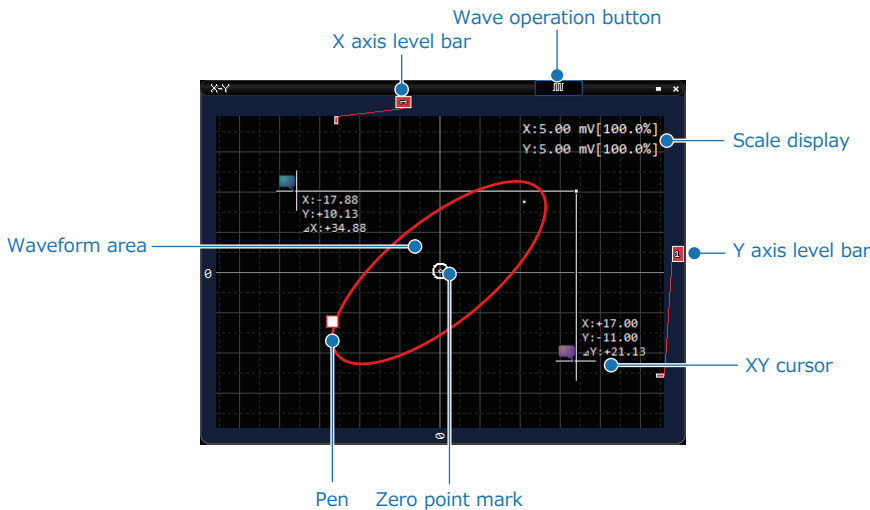

Name	Explanation
Wave operation button	Displays the signal position of each channel. The vertical position of the waveform can be changed by using the mouse to drag the level bar.
Scale display	Displays the displayed width per grid of the waveform along the XY axes and the vernier value (waveform display adjustment function).
X/Y axis level bar	Displays each channel's signal position. If the level bar is dragged with the mouse, the upper and lower values of the waveform can be changed.
Waveform area	The area in which the X-Y waveform is drawn. The X-Y waveform position can be changed by dragging the mouse.
X-Y cursor	The level value and differential value at any position on the X-Y waveform can be confirmed. The icon can be moved to any position by moving it with the mouse.
Pen	Displays the plot of the active channel's signal value. During recording, it is drawn with a solid line.

Waveform operation button

Used to operate the waveform during X-Y waveform display.

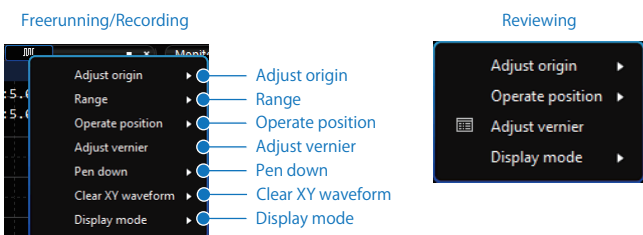

Name	Explanation
Adjust origin	Adjusts the origin position.
Range	Changes the range. Changes can only be made during free-running and recording. The range is linked with the amplifier range.

Operate position	Changes the display position of the XY waveform. The position can also be changed by dragging the waveform area.	
Adjust vernier	Simultaneously by making changed with the mouse wheel over the waveform area.	
Pen down	Sets the status of the pen. The pen is lowered at the start of recording regardless of this setting.	
	Up	Raises the pen. When the pen is raised, the waveform will not be drawn and the pen mark will simply move.
	Down	Lowers the pen. Draws the waveform.
Clear XY waveform	Clears the waveform.	
Display mode	Switches the screen mode.	

Adjust origin

Adjusts the origin of the X-Y waveform display.

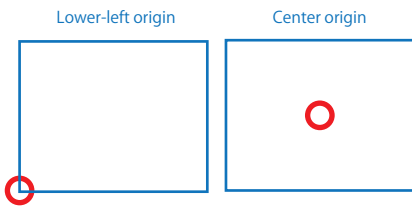

Range

Changes the range. Changes can only be made during free-running and recording. The range is linked with the amplifier range.

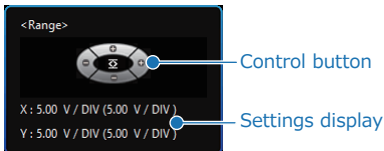

Position

Changes the display position of the XY waveform.

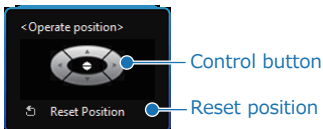

Vernier

Adjusts the waveform display expansion ratio.

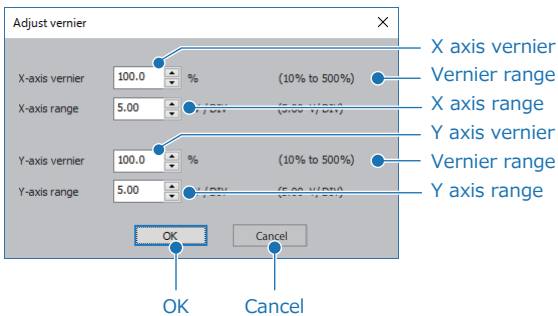

• X-Y Pen

The raised/lowered state of the pen can be selected during free-running. The pen is forced down at the start of recording.

When the pen is raised

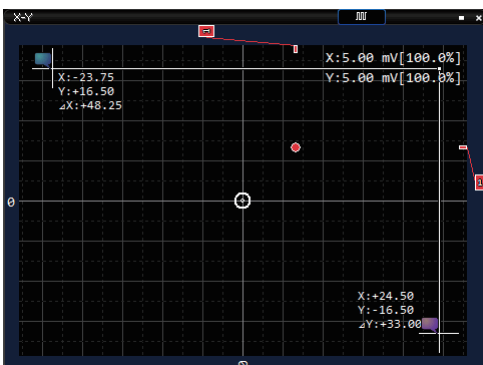

When the pen is lowered

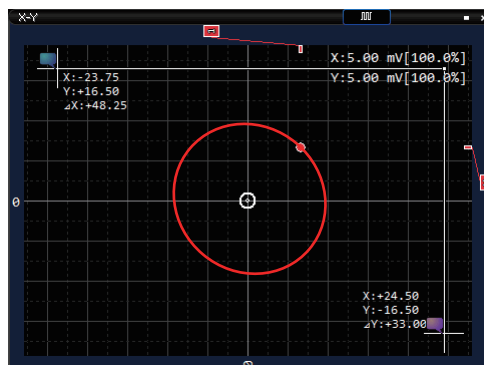

- **Cursor Display**

Check the signal level, level difference between the two points, etc. using the cursor displayed in the waveform screen.

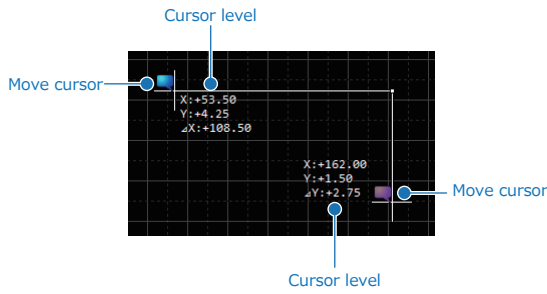

Name	Explanation								
Cursor move button	The Cursor Move button allows you to move to any position within the waveform between the two cursor points.								
Cursor level	Displays the level of the point indicated by each cursor movement button. <table border="1"> <tr> <td>X</td> <td>Displays the level of the X axis indicated by the cursor.</td> </tr> <tr> <td>Y</td> <td>Displays the level of the Y axis indicated by the cursor.</td> </tr> <tr> <td>delta X</td> <td>Displays the differential level of the cursor on the X axis.</td> </tr> <tr> <td>delta Y</td> <td>Displays the differential level of the cursor on the Y axis.</td> </tr> </table>	X	Displays the level of the X axis indicated by the cursor.	Y	Displays the level of the Y axis indicated by the cursor.	delta X	Displays the differential level of the cursor on the X axis.	delta Y	Displays the differential level of the cursor on the Y axis.
X	Displays the level of the X axis indicated by the cursor.								
Y	Displays the level of the Y axis indicated by the cursor.								
delta X	Displays the differential level of the cursor on the X axis.								
delta Y	Displays the differential level of the cursor on the Y axis.								

13-2. Time Line Window

You can use the Y-T wave form window to view everything. The digital monitor allows 1 channel's wave form to be displayed.

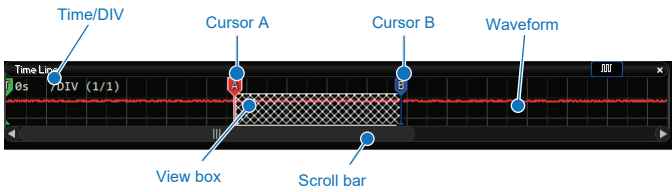

Name	Explanation
Time/DIV	Display the Time/DIV value of the currently displayed waveform. Time/DIV displays time to one 1 grid axis. For 1sec/DIV1 grid's display axis is 1 second.
Waveform	Displays the waveform. The active channel's wave form is displayed on the digital monitor.
Cursor A and B	The cursor A and B is displayed during viewing. Move them arbitrarily. The data between the cursor A and B is subject to the X-Y process during X-Y viewing. However, the process depends on the averaging setting.
View box	Displays the displayed range between A and B with a shaded box. Displays the shaded range with a X-Y waveform. <div data-bbox="571 891 1114 1258" data-label="Image"> </div>
Scroll bar	If you drag the scroll bar with the mouse during data playback, you can move the time axis.

13-3. Monitor Window

This is a window that displays the signal's level value. A single X-Y channel, which consists of the CH of the X side and CH of the Y side, is displayed in the X-Y display. During free-running or recording, the most up-to-date data is updated every 0.5 seconds. The signal level value on the cursor selected by the cursor A or B in Timeline Window is displayed during viewing. Depending on the window size, the mode of each type (Digital, Statistics calculation, Expanding digital) can be set.

13-3-1. Digital

This display mode shows wave form displays lined up with each other.

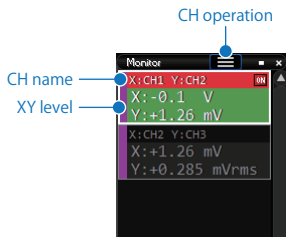

Name	Explanation	
CH operation	Used to perform CH operations related to the Monitor Window.	
X-Y Channel number	Up to 4 channels of X-Y number are displayed.	
X-Y level	Displays signal level during free running, recording, or reviewing.	
	Free running	Displays the newest entered signal level from a device. It is refreshed every 0.5 seconds.
	Recording	Selecting either cursor A or B will display the signal level value of the chosen cursor.
	Reviewing	Selecting either cursor A or B will display the signal level value of the chosen cursor.

13-3-2. Statistics calculation

This mode is a wide range display that does not show waveform display. In wide display, statistics calculations can be performed.

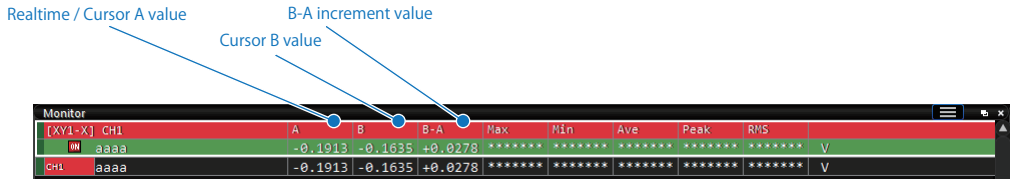

Name	Explanation
Real time / Cursor A value	Displays the newest real time signal level value from free running or recording in progress. Signal level is displayed above cursor A during reviewing.
Cursor B value	Signal level is displayed above cursor B during reviewing.
B-A increment value	Displays Cursor B and Cursor A's increment value during ewviewing.

- **Group Creation in X-Y Mode**

The copy tab group only can be created In X-Y Mode. The different devices and the channel data in the file can not be mixed as well as Y-T Mode.

<Example of copy group creation from the Device tab>

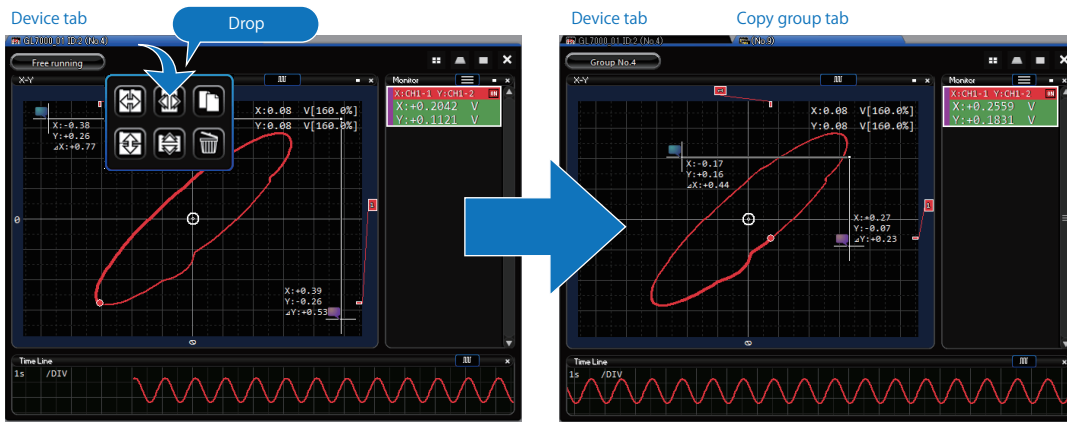

13-4. X-Y Waveform Control Panel

13-4-1. Main Panel

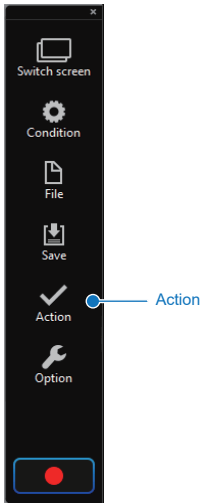

Name	Explanation
Action	Changes to the panel associated with the action.

13-4-2. Action

Changes to the panel associated with the action.



Name	Explanation
Clear X-Y waveform	Clear X-Y Waveform display during recording. The displayed waveform is cleared, the data itself is not cleared.
Adjust all autobalance	Displayed when the strain unit is connected. Opens the batch auto balance adjustment screen.(GL-Connection Ver. 2.20 or later)

- X-Y Waveform Clear

Clear the X-Y Waveform display.

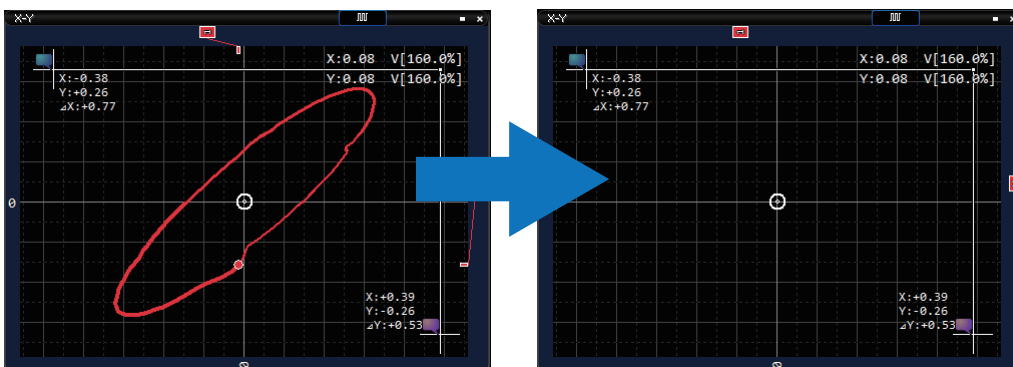

14. FFT Waveform Mode

The frequency is displayed on the X axis, and the level is displayed on the Y axis of this graph in FFT Display Mode. During free running, the waveform is displayed in real-time, or any range of the waveform can be displayed after viewing the recorded file. Also, Check the difference between the levels as well as the frequency width and detect the peak with the cursor A and B.

* The settings in the FFT Waveform Mode do not interact mutually with the device such as GL7000. The settings are enabled only in the software.

14-1. Waveform Window

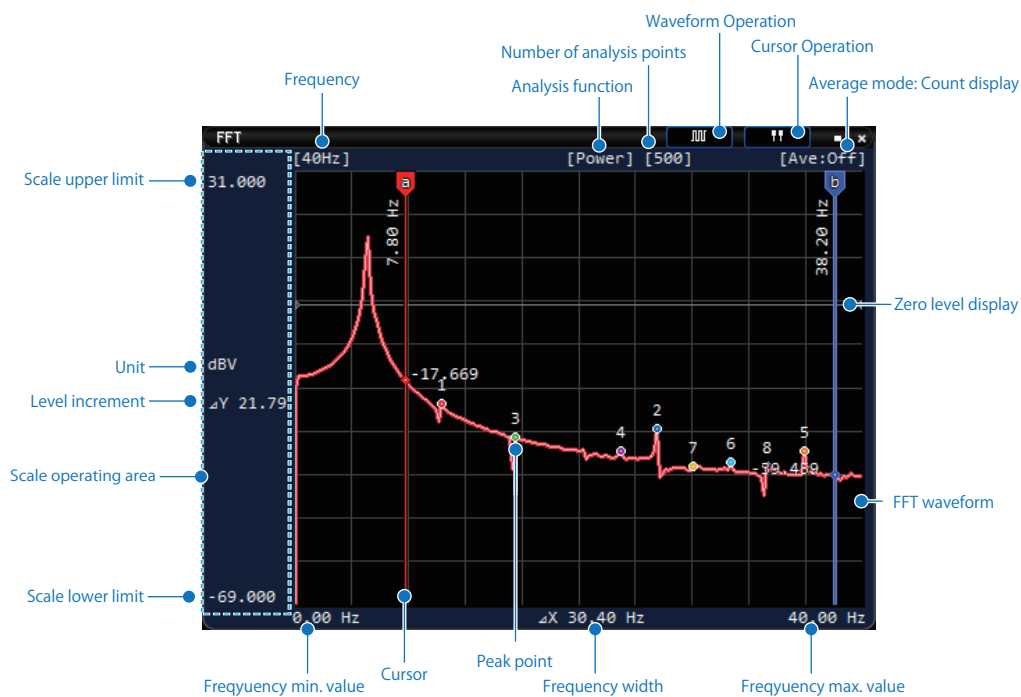

Name	Explanation
Frequency	Display the analysis frequency.
Analysis function	Displays the analyzing function.
Number of analysis points	Displays the analyzing points.
Waveform Operation	Functions in regard to waveform operation are aggregated.
Cursor Operation	Functions in regard to the cursor are aggregated.
Average mode: Count display	Average mode: Displays the averaging process. Count display: Displays the average count.
Level value	Displays the level value.
Frequency value	Displays the frequency value.
Level increment	Displays the level increment.
Frequency increment	Display the frequency increment.
Zero level display	Draws the line at zero level.
Cursor	There are two movable cursors (A and B) in FFT Window. The frequency value, level value of intersected active channel, and point value from the beginning by placing the mouse on the cursor is displayed by placing the mouse on the cursor. Also, specify the range of peak point. For details, refer to Cursor
Scale operating area	The scale operation can be performed by dragging up or down or operating the wheel.

FFT waveform	Displays FFT waveform. Up to 4 channels can be displayed. Display the active channel in the Monitor Window on the top.
Peak point	Up to 10 points are displayed after detecting the peaks within the waveform. For how to detect the peak points, refer to Peak filter pad and peak filter point

14-1-1. Waveform Opeartion

During FFT waveform display, Operated the waveform.

During free-running and recording

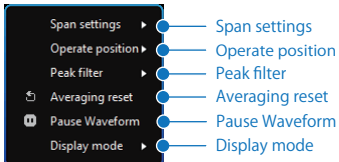

During replaying

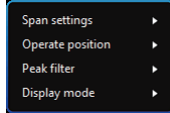

Name	Explanation
Span Settings	Perform the waveform scaling.
Operate position	Moves to the top and bottom, the left and right within Waveform Window.
Peak filter	Filters the peak detect conditions depending on the position of the peak point within the peak pad.
Averaging reset	The averaging reset is performed during free running and recorded. This is applied when the averaging process is enabled.
Pause Waveform	Pauses the waveform display. This does not affect data recording. Only available while free-running and recording.
Display mode	Change display mode.

• Peak filter pad and peak filter point

Filters the peak points by combining the neighborhood range and the peak drop.

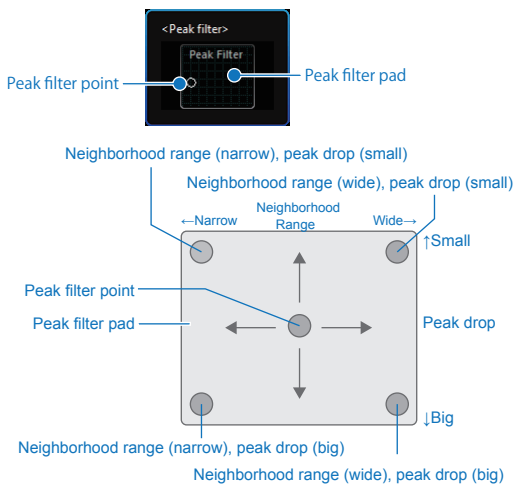

Neighborhood Range

Filters the X-axis ranges of certain interval in the order in which they found from the left side.

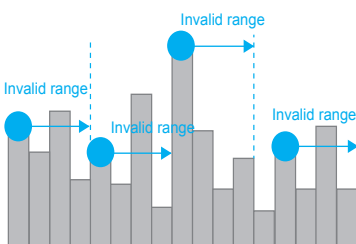

Peak Drop

Filters the peak points below peak drop set arbitrarily.

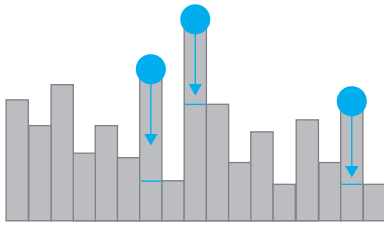

14-1-2. Cursor Operation

During FFT waveform display, Operated the cursor.

Expand between cursors Expand between cursors
 Release expansion between cursors Release expansion between cursors

Name	Explanation
Expand between cursors	Expands the area between cursor a and b to the screen width.
Release expansion between cursors	Returns the expansion between the cursors to the original state.

14-1-3. FFT Waveform

- Enlarged waveform during viewing

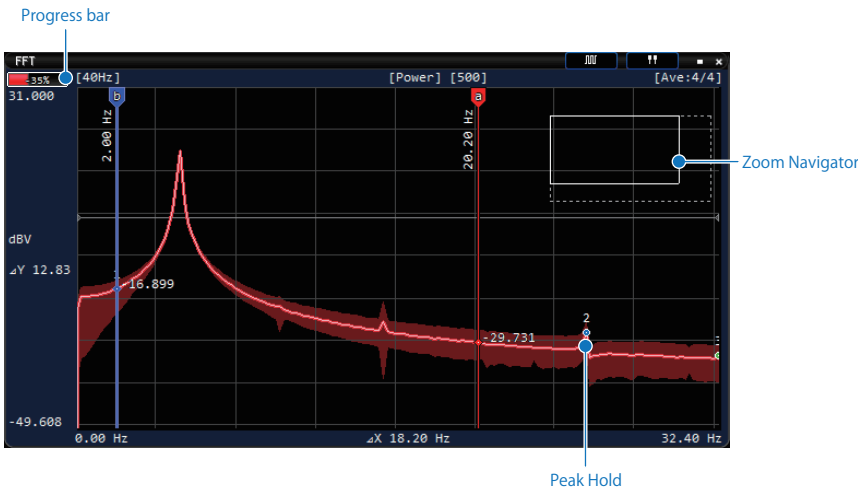

Name	Explanation
Peak hold	<p>When the peak hold function is enabled during free running, recording or viewing, the range between the maximum and minimum values is filled and displayed.</p> <p>During free running or recording: All the waveforms are applied to the peak hold in real time.</p> <p>During viewing: When the average mode is enabled, the peak hold is applied.</p>
Zoom Navigator	<p>The Zoom Navigator is displayed when operating the waveform in Control Panel or enlarging the waveform with the mouse wheel. The dotted line represents the entire size of the Waveform Window, a solid line represents the range currently displayed.</p>
Progress bar	<p>The progress bar is displayed when FFT process is performed.</p> <p> : This bar is displayed until the number of analysis points appear in the initial display. During this period, the Waveform display will be undefined.</p> <p> : This bar is displayed until the number of analysis points completely appear in the second display and subsequent display.</p>

• Nyquist display

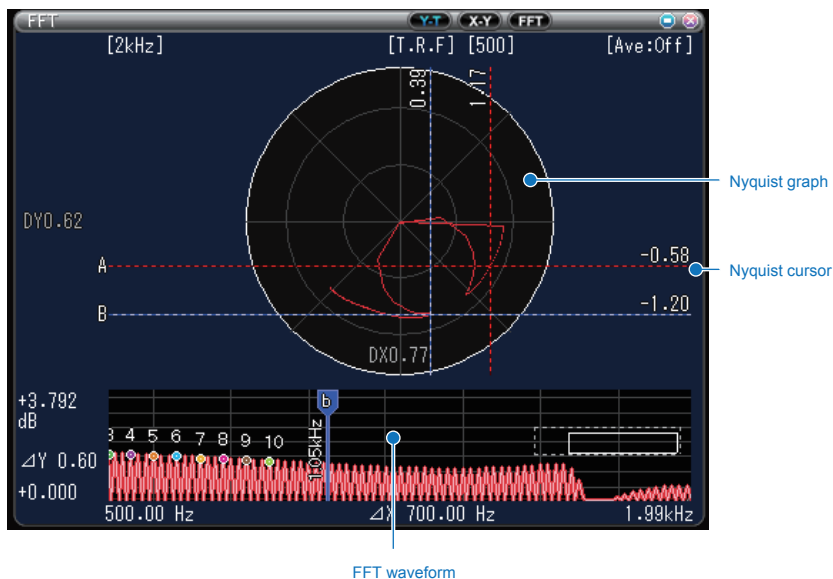

Name	Explanation
Nyquist graph	This is a waveform displayed when switching to Nyquist Mode. The display can be changed in FFT settings.
Nyquist cursor	This is a cursor used for Nyquist FFT display.
FFT waveform	This is a FFT waveform used for Nyquist FFT display.

14-1-4. Peak Point

The peak between the FFT Waveform-shaped cursor A and B is detected and up to 10 peak points are displayed. Check the frequency and level values by placing the mouse on the each peak point. Also, unnecessary peak points can be filtered by setting the peak filter in Control Panel.

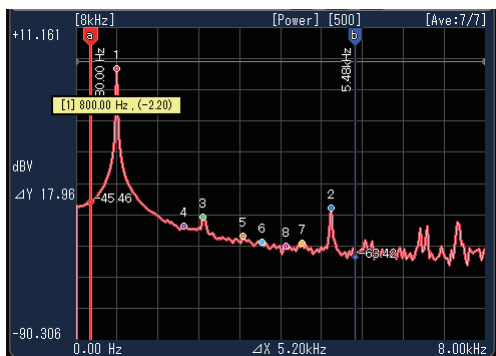

14-1-5. Zoom Navigator

When enlarging the waveform in Control Panel or with mouse wheel, the Zoom Navigator is displayed on the waveform. Check the position in the entire waveform.

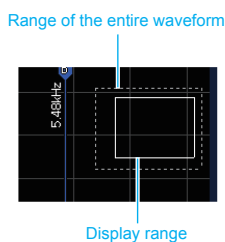

14-1-6. Operations in Waveform Window

- **Waveform Scaling**

The waveform scaling can be performed by operating the mouse wheel on the waveform. The Zoom Navigator is displayed during scaling. Check the display position in the entire waveform.

- **Waveform Moving**

In waveform scaling operation, the waveform can be moved by dragging the mouse to the desired position within the waveform. Use Zoom Navigator to check the scaling state.

- **Scale Position Moving**

The scale position can be moved by dragging the mouse on the scale.

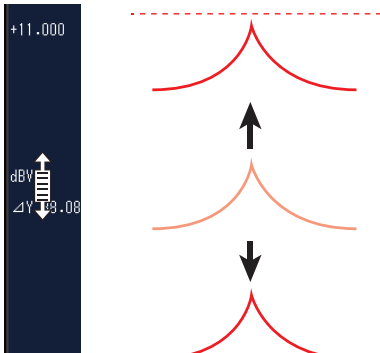

- **Scaling**

The waveform scaling is possible by operating the mouse wheel when the mouse is on the scale.

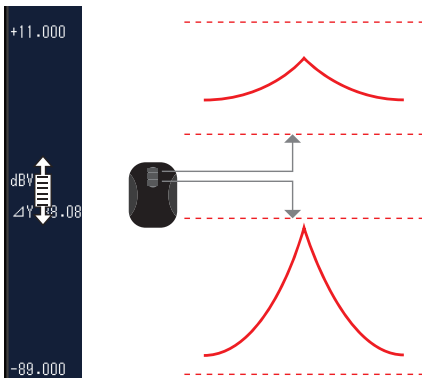

- **Cursor**

There are two cursors (A and B) in the window. Each cursor can be freely moved by dragging the mouse within the waveform. The frequency and level values on the position of the cursor are displayed. In addition, the pop-up is displayed by placing the mouse on the cursor. Check the data points from the leftmost.

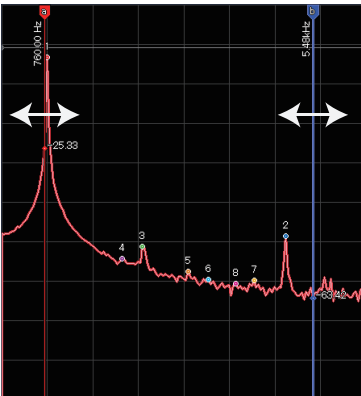

Simultaneously, the cursor A and B can be used to specify the detection range of the peak points on the waveform.

The detection range “a<->b” and “b<->a” are different, the range is reversed.

*When the X axis is assigned to the period display, the detection range is reversed.

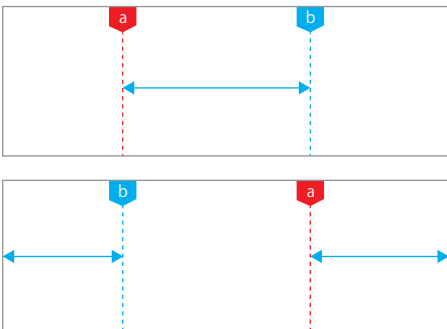

14-2. Timeline Window

During free running or recording, this window is displayed as well as Y-T Waveform Mode. During viewing, the range of FFT process can be set with the timeline cursor A and B.

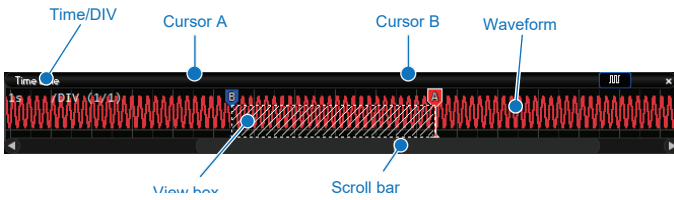

Name	Explanation
Time/DIV	Displays the Time/DIV value of the displayed waveform. Time/DIV represents the time in one grid width. When 1sec/DIV is set, the one grid width is 1 sec.
Waveform	Displays the waveform. The waveform of the active channel in the digital monitor is displayed.
Cursor A and B	The cursor A and B is displayed during viewing. Move them arbitrarily. The data between the cursor A and B is subject to the FFT process during FFT viewing. However, the process depends on the averaging setting.
View box	Displays the displayed range between A and B with a shaded box. The FFT waveform within the translucent range is displayed. <div style="text-align: center;"> </div> <p>When the average mode is enabled, the data analysis and waveform display is performed for each number of analysis points.</p> <div style="text-align: center;"> </div>
Scroll bar	The time base can be moved by dragging the scroll bar with the mouse during data viewing.

14-2-1. Operations in Timeline Window

- **Scrolling the waveform**

The time base can be moved by dragging the scroll bar with the mouse during viewing.

- **Changing the Time/DIV**

Press the Time/DIV button to change the Time/DIV. Also, the Time/DIV can be changed by operating the mouse wheel when the mouse pointer is on the Timeline Window.

- **Moving the cursor**

During viewing, the cursor A and B can be moved. The cursor behavior varies depending on the averaging setting in FFT settings.

Averaging Off: The cursor A and B are fixed within the number of analysis points in FFT settings. The cursor A and B can be moved in synchronization.

Averaging On: The cursor A and B can be moved individually. The average count of the data points within the cursor range is calculated with the number of analysis points of FFT settings and then the averaging process is performed.

14-3. Monitor Window

Display the peak and frequency values from the FFT calculation result. During free-running or recording, the most up-to-date data is updated every 0.5 seconds. During viewing, the last FFT process value is displayed. The mode of each type (Digital, Statistics calculation) can be set.

14-3-1. Digital Display

This is a display mode used when displaying side-by-side with the Waveform display.

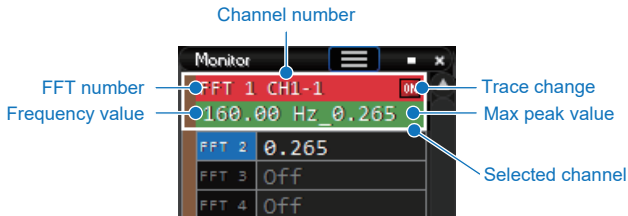

Name	Explanation				
FFT number and Channel number	<p>FFT number: Displays the FFT number 1 to 4.</p> <p>Channel number: Displays the Channel number of the FFT channel A set in the setting menu. The number is structured as [Module No.]-[Channel No.].</p>				
Selected channel	<p>The following items in respect of the selected channel are displayed or operated.</p> <p>More than one channel can be selected by click the mouse while holding down the Shift key or the Ctrl key on the keyboard. The background of the selected channel changes to green.</p> <table border="1"> <tr> <td>Waveform Window</td> <td> Displayed in front Level display Frequency display Level difference of X axis and Y axis </td> </tr> <tr> <td>Timeline Window</td> <td>Waveform display</td> </tr> </table>	Waveform Window	Displayed in front Level display Frequency display Level difference of X axis and Y axis	Timeline Window	Waveform display
Waveform Window	Displayed in front Level display Frequency display Level difference of X axis and Y axis				
Timeline Window	Waveform display				
Maximum peak value	Displays the frequency of the maximum peak value.				
Frequency value	Displays the frequency of the maximum peak value.				
Trace change	Changes On/Off for each FFT channel.				

14-3-2. Statistics Calculation Display

A wide-width display mode that hides the waveform display. You can switch to the wide screen by pressing the Maximize button on the Digital Screen. Statistical calculations can be displayed in the wide mode.

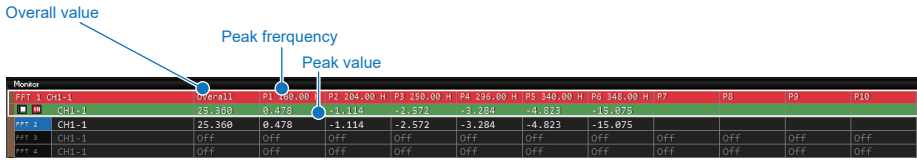

Name	Explanation
Overall value	Displays the total value of each frequency component.
Peak frequency	Displays up to 10 peak values detected. For how to detect the peak point, follow the range of the cursor (A and B) and the peak filter (Refer to Peak filter pad and peak filter point).
Peak value	Displays the peak value.

- Group creation at FFT Mode

The copy tab group only can be created in FFT Mode. The different devices and the channel data in the file can not be mixed as well as Y-T mode.

<Example of group creation from the Device tab>

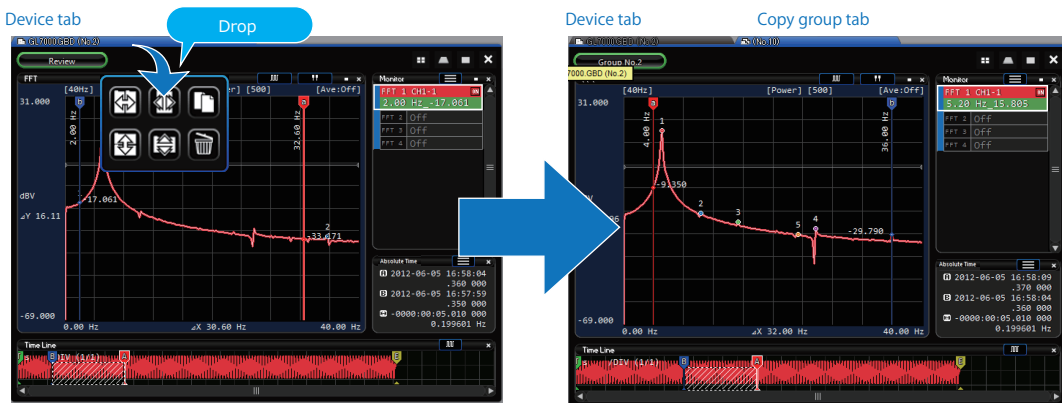

15. Device Settings

This is the screen to set recording and connection device settings. Device setting is available when the device is connected and not recording. The settings items in the following settings screen shows the setting of the device transmission when the basic parameters have been changed.

To go to the device setting screen, press the control panel button in the main window.

Press the control panel button in the main window to access the device settings screen.

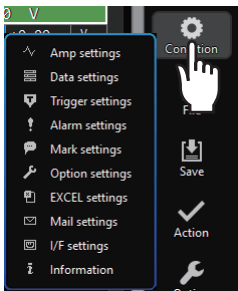

15-1. Main Settings

Displays each function. A window opens for each function when the corresponding item is selected.

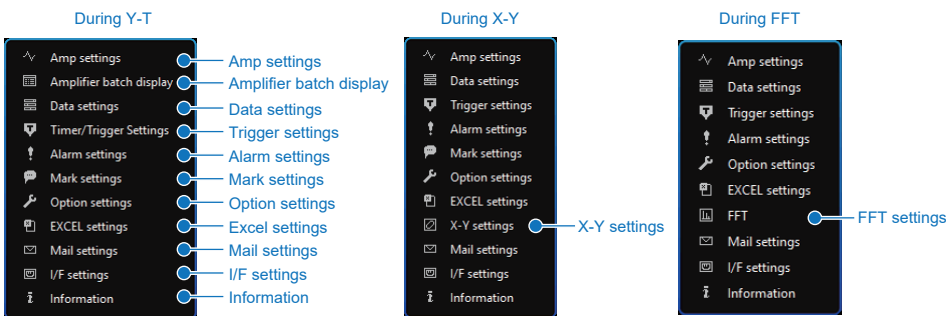

Name	Explanation
Amplifier module settings	Performs connected amplifier module setting, analog input setting, logic pulse input setting, trigger level setting, alarm level setting, etc.
Amplifier batch display	Compatible with version 2.20 or later. This function can only be used with the GL7000. A list of settings for the GL7000 unit is displayed. * The voltage output unit is not displayed.
Data settings	Performs settings related to recording like sampling interval setting, device recording setting, PC recording setting.
Trigger settings	Set conditional trigger for the start and stop of recording.
Alarm settings	Set the requirements for signal sending to the alarm output port.
Mark settings	Set the marks displayed on the waveform.
Option Settings	Configure option settings.
Excel settings	Configure direct Excel transfer settings. For this function to work, Microsoft Excel must be installed and able to be used.
Mail settings	For mails that alerts the occurring of alarms when using the alarm function. To use this function, the PC must allow sending of mails. Depending on the mail-sending SMTP server, there are cases in which mails cannot be sent.
I/F settings	To perform interface settings.
Information	Shows information like the device version.
X-Y settings	Used to configure settings for the XY waveform mode.
FFT settings	Used to configure settings for the FFT waveform mode.

15-2. Amplifier Module Settings

Performs connected amplifier module setting, analog input setting, logic pulse input setting, trigger level setting, alarm level setting, etc. By pressing the connected amplifier module setting button, setting window of individual modules will be opened.

15-2-1. Amplifier Module Settings Screen

Can change the tabs related to the amplifier in the amplifier module settings display.

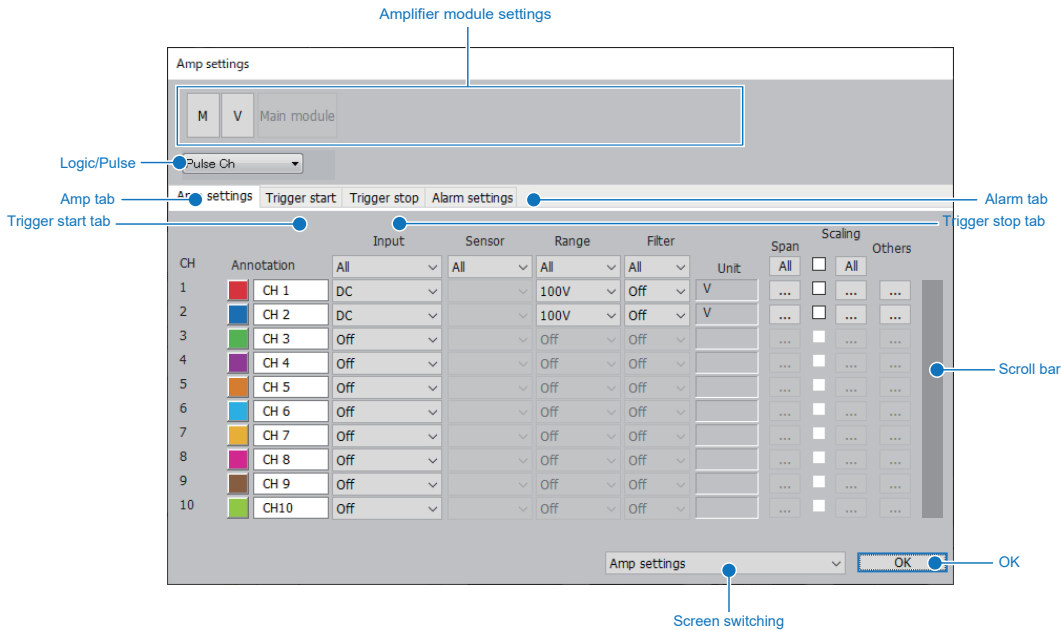

When using the GL860, GL260, GL240, GL840 and GLT400

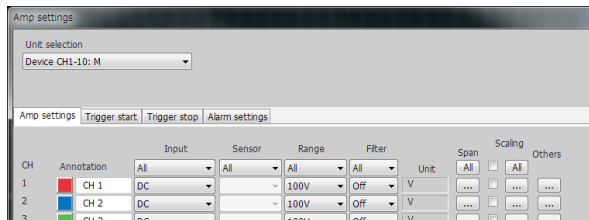

Name	Explanation
Amplifier module settings	Displays the settings of the connected amplifier module.
Logic/Pulse	Switching of logic pulse. Amplifier module only shows logic/pulse modules.
Amp tab	Configure input related settings.
Trigger start tab	Configure Trigger-start tab related settings.
Trigger stop tab	Performs settings related to trigger stop.
Alarm tab	Performs settings related to alarm.
Scroll Bar	Appears when more than 10 channels are displayed in the amplifier tab and allows the switching between channel lists.
Screen switching	You can move to various setting screens.
OK	Closes the window.

15-2-2. Amplifier Setting tab: Voltage, Voltage/temperature, High-speed Voltage, High-voltage Modules, GL860, GL260, GL840, GL240, GL980, GL2000 and GLT400

Set the amplifier tab when the Voltage, Voltage/temperature, High-speed Voltage or High-voltage Modules are connected.

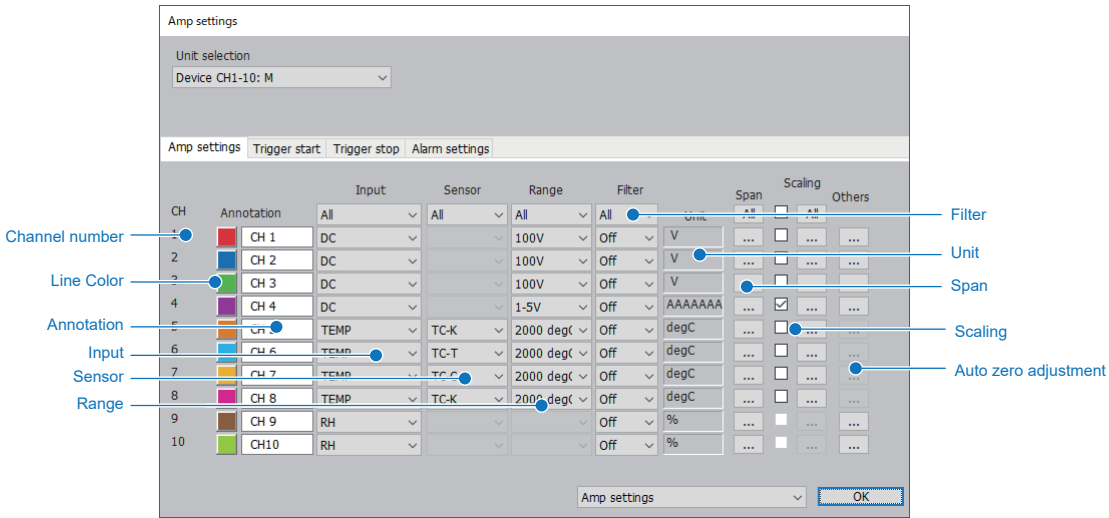

Name	Explanation
Channel number	Displays the input signal's module number and channel number. GL7000: [Module number]-[Channel number] GL860, GL260, GL840, GL240, GL980, GL2000 and GLT400 : [Channel number]
Line color	It is possible to set the waveform color.
Annotation	It is possible to input signal names to each channel. Up to a maximum of 31 characters can be entered.
Input	To select input. There may be difference in the selection value depending on the type of machine or amplifier module. For more details, please refer to the main module's user's manual.
Range	To select the input range. There may be difference in the selection value depending on the type of machine or amplifier module. For more details, please refer to the main module's user's manual.
Filter	To select a filter There may be difference in the selection value depending on the type of machine or amplifier module. For more details, please refer to the main module's user's manual.
Unit	Displays the unit.
Span	To set the upper value and lower value of the signal displayed in the waveform window.
Scaling	Unit conversion. When the voltage input is set to 4-point, it is possible to set the temperature input as offset. * When CSV file playback is forced to On.
Other	Used to configure the zero-point automatic adjustment function and the root mean square value calculation cross values. (*RMS value calculation cross value settings are only available with GL980, GL2000.)

• Span Setting

To set the span. The setting is done by inputting numerical values.

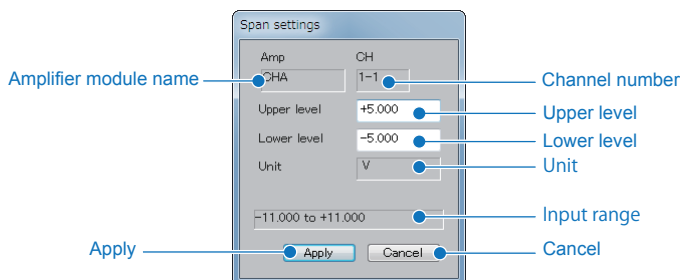

Name	Explanation
Amplifier module name	Displays the names of all module amplifiers that are being configured.
Channel number	Displays the input signal's module number and channel number. GL7000: [Module number]-[Channel number] GL860, GL260, GL840, GL240, GL980, GL2000 and GLT400 : [Channel number]
Upper level	To input the span upper value. The largest value during voltage input is $\pm 110\%$ of the full scale (range). That temperature input is from $+2000^{\circ}\text{C}$ to -270°C (Celsius). That during humidity input is from $+110\%$ to -110% .
Lower level	To input the span lower value. The largest value during voltage input is $\pm 110\%$ of the full scale (range). That temperature input is from $+2000^{\circ}\text{C}$ to -270°C (Celsius). That during humidity input is from $+110\%$ to -110% .
Unit	Displays the unit.
Input range	Display input range.
Apply	Transmits entered values to the main module.
Cancel	Cancel and close input information..

• **Scaling Setting**

Changes the scaling setting. Setting is done by inputting the upper and lower values of both the input side and the conversion side. It is possible to set 2-point offset during temperature input.

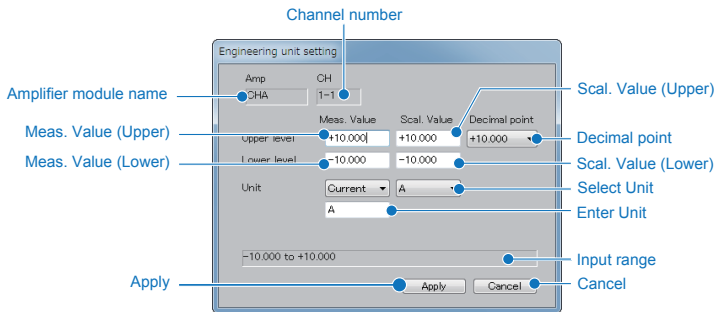

Name	Explanation
Amplifier module name	Displays the names of all module amplifiers that are being configured.
Channel number	Displays the input signal's module number and channel number. GL7000: [Module number]-[Channel number] GL860, GL260, GL840, GL240, GL980, GL2000 and GLT400 : [Channel number]
Measured value (Upper/Lower)	To set the upper value/lower value of the original value. There is not difference between the upper value/lower value during temperature input.
Scaling value (Upper/Lower)	To set the post-conversion upper value/lower value There is not difference between the upper value/lower value during temperature input.
Decimal point	Set decimal point position on output side.
Select unit	Select the unit.
Enter Unit	To input the post-conversion unit. Up to a maximum of 8 characters can be entered.
Input range	Display input range.
Apply	Transmits entered values to the main module.
Cancel	Cancel and close input information.

• **Auto zero adjustment**

To adjust the current input value to zero-point. The automatic adjustment range is $\pm 10\%$ of the setting range. The automatic adjustment value is reset when the range of the channel is switched.

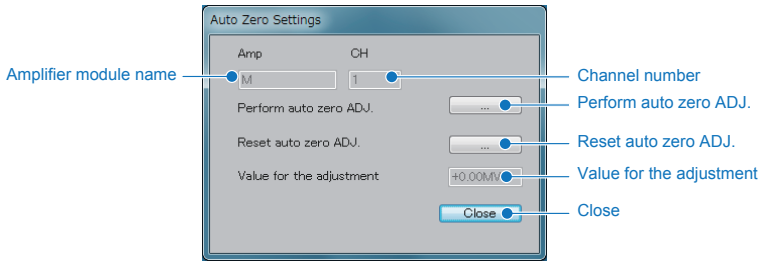

Name	Explanation
Amplifier module name	Displays the names of all module amplifiers that are being configured.
Channel Number	Displays the input signal's module number and channel number. GL7000: [Module number]-[Channel number] GL860, GL260, GL840, GL240, GL980, GL2000 and GLT400 : [Channel number]
Perform auto zero adjustment	To perform zero-point automatic adjustment.
Reset auto zero adjustment	To delete the zero-point voltage value.
Value for the adjustment	Displays the value for the adjustment.
Close	Closes the screen.

• **RMS value calculation cross value settings**

When an RMS (root mean square value) has been set with GL980 or GL2000, set the threshold value for detecting a single cycle of the input signal.

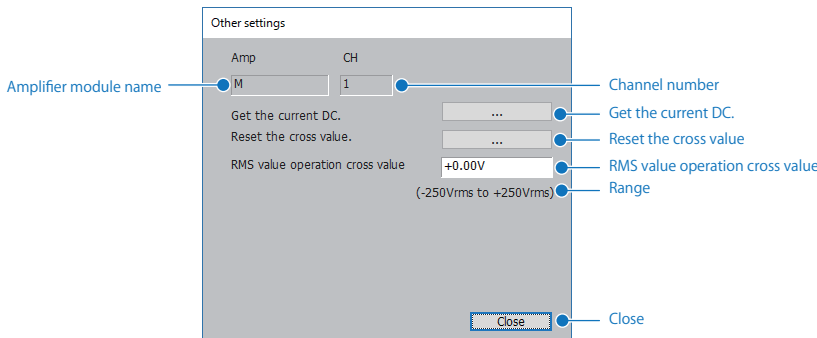

Name	Explanation
Amplifier module name	Displays the names of all module amplifiers that are being configured.
Channel Number	Displays the input signal's module number and channel number.
Get the current DC	Sets the current input signal voltage as the specified value.
Reset the cross value	Releases the configured value.
RMS value operation cross value	Input a value of your choice.
Close	Closes the screen.

• **Burnout check**

Performs a check for broken wires when a temperature has been set with GL980 or GL2000.

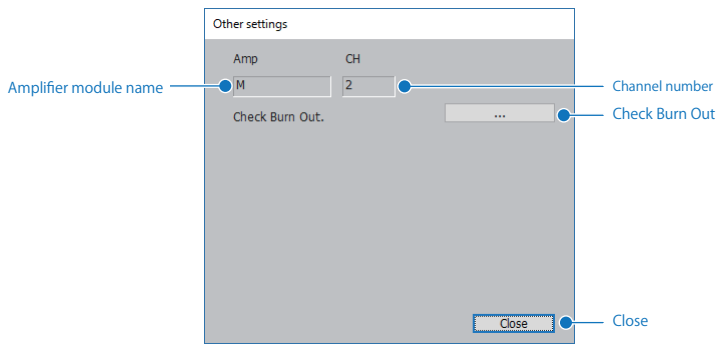

Name	Explanation
Amplifier module name	Displays the names of all module amplifiers that are being configured.
Channel Number	Displays the input signal's module number and channel number.
Burnout check	Performs a burnout check.
Close	Closes the screen.

Check results

<When connected>

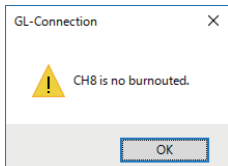

<When disconnected>

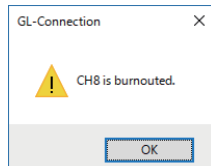

15-2-3. Amplifier Setting tab: DC Strain Module

Set the amplifier tab when the DC Strain Module is connected.

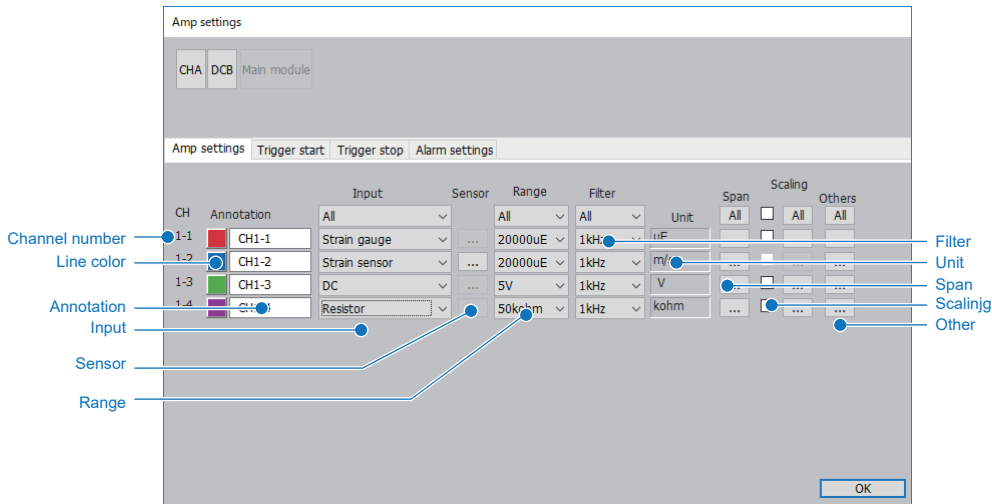

Name	Explanation
Channel number	Displays the input signal's module number and channel number. [Module number]-[Channel number]
Line color	It is possible to set the waveform color.
Annotation	It is possible to input signal names to each channel. Up to a maximum of 31 characters can be entered.
Input	Select the input. The sensor menu is displayed after selecting it. The selected value varies depending on the type of device and amplifier module.
Range	To select the input range. There may be difference in the selection value depending on the type of machine or amplifier module. For more details, refer to the main module's User's Manual.
Sensor	Changes the sensor settings.
Filter	To select a filter There may be difference in the selection value depending on the type of machine or amplifier module. For details, refer to the main module's User's Manual.
Unit	Displays the unit.
Span	To set the upper value and lower value of the signal displayed in the Waveform Window.
Scaling	Unit conversion. When the voltage input is set to 4-point, it is possible to set the temperature input as offset. * When CSV file playback is forced to On.
Other	Set the other settings. In the Other in "All", the auto-balancing only can be set.

• **Sensor setting**

Set the sensor. The settings vary depending on the input state.

When the strain gauge is used

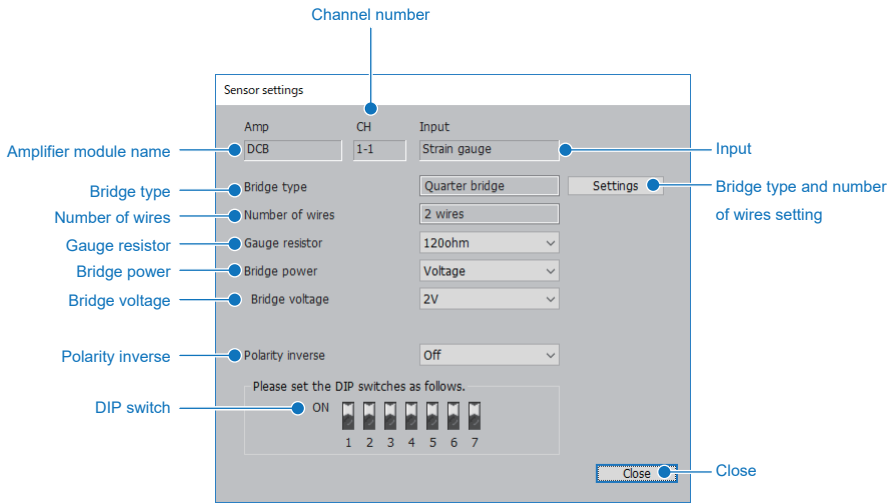

Name	Explanation								
Amplifier module name	Displays the names of all module amplifiers that are being configured.								
Channel number	Displays the input signal's module number and channel number. [Module number]-[Channel number]								
Input	Displays the settings have been set.								
Bridge type	Displays the set bridge type.								
Number of wires	Displays the set number of wires.								
Bridge type and number of wires settings	Set the bridge type and the number of wires.								
Gauge resistor	Set the gauge resistor. <table border="1" style="width: 100%; border-collapse: collapse;"> <thead> <tr> <th style="width: 50%;">Bridge type</th> <th style="width: 50%;">Settings</th> </tr> </thead> <tbody> <tr> <td>Quarter bridge</td> <td>120/350 (Ω)</td> </tr> <tr> <td>Half bridge</td> <td></td> </tr> <tr> <td>Full bridge</td> <td>50 to 10000 (Ω)</td> </tr> </tbody> </table>	Bridge type	Settings	Quarter bridge	120/350 (Ω)	Half bridge		Full bridge	50 to 10000 (Ω)
Bridge type	Settings								
Quarter bridge	120/350 (Ω)								
Half bridge									
Full bridge	50 to 10000 (Ω)								
Bridge power	Set the bridge power. Voltage/Constant current * When the quarter bridge (3 wires, 4 wires), half bridge (4 wires) and full bridge (6 wires) are used, the voltage only can be set.								
Bridge voltage (Targeted bridge voltage)	Set the bridge voltage (when the bridge power is voltage) and the targeted bridge voltage (when the bridge power is constant current).								
Polarity inverse	Set the polarity inverse. Off/On								
DIP switch	Set the DIP switch on the DC Strain Module in accordance with the sensor settings.								

Bridge type and Number of wires

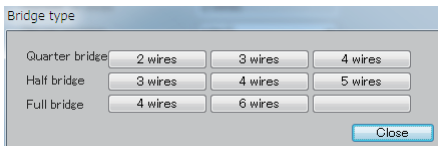

Bridge type	Settings
Quarter bridge	2 / 3 (S) / 4 (S) wires
Half bridge	3 / 4 / 5 (S) wires
Full bridge	4 / 6 wires

* (S) indicates that the shunt calibration is available.

When the strain sensor is used

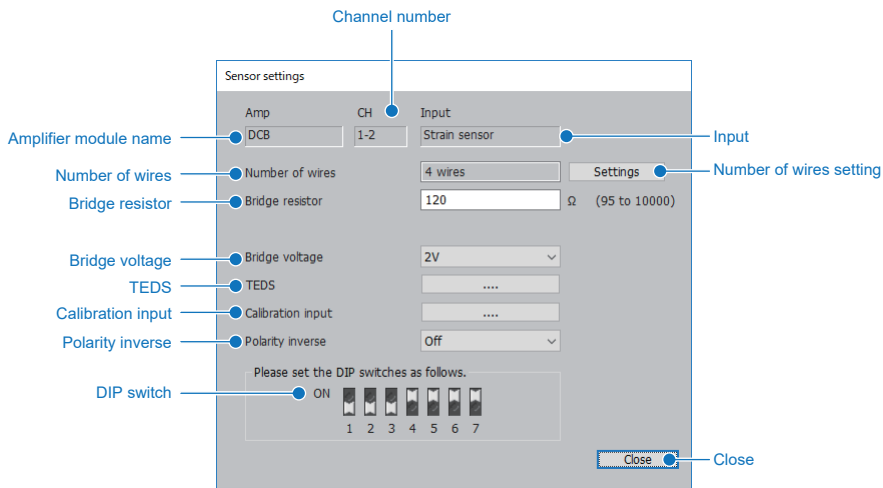

Name	Explanation
Amplifier module name	Displays the names of all module amplifiers that are being configured.
Channel number	Displays the input signal's module number and channel number. [Module number]-[Channel number]
Input	Displays the settings have been input.
Number of wires	Displays the number of wires has been set.
Number of wires setting	Set the bridge type and Number of wires.
Bridge resistor	Set the bridge resistor. 50 to 10000 (Ω)
Bridge voltage	Set the bridge voltage.
TEDS	Open the TEDS menu.
Calibration input	Open the Calibration Input menu.
Polarity inverse	Set the polarity inverse. Off/On
DIP switch	Set the DIP switch on the DC Strain Module in accordance with the sensor settings.

Number of wires setting

Set the number of wires (4/6 wires).

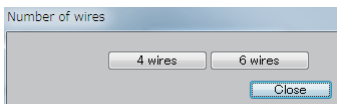

TEDS

When TEDS-compatible sensor is connected, TEDS information is read, or the file is saved or read.

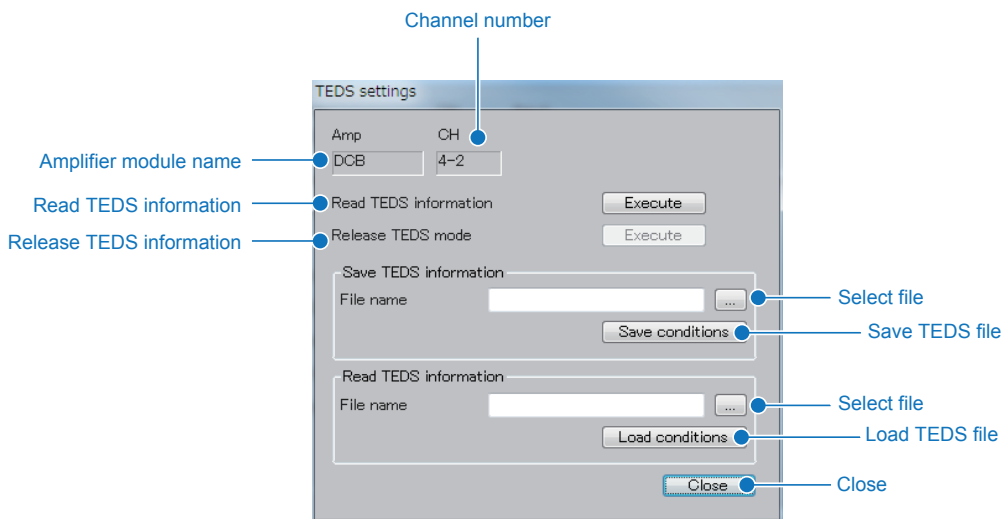

Name	Explanation
Amplifier module name	Displays the names of all module amplifiers that are being configured.
Channel number	Displays the input signal's module number and channel number. [Module number]-[Channel number]
Read TEDS information	Read TEDS information from the internal TEDS sensor.
Release TEDS information	Release TEDS information read from the internal TEDS sensor.
Save TEDS file	Save TEDS information in a file.
Read TEDS file	Read TEDS information file.
Select file	Select a file from the module.
Close	Closes the window.

Calibration input

Perform the calibration input.

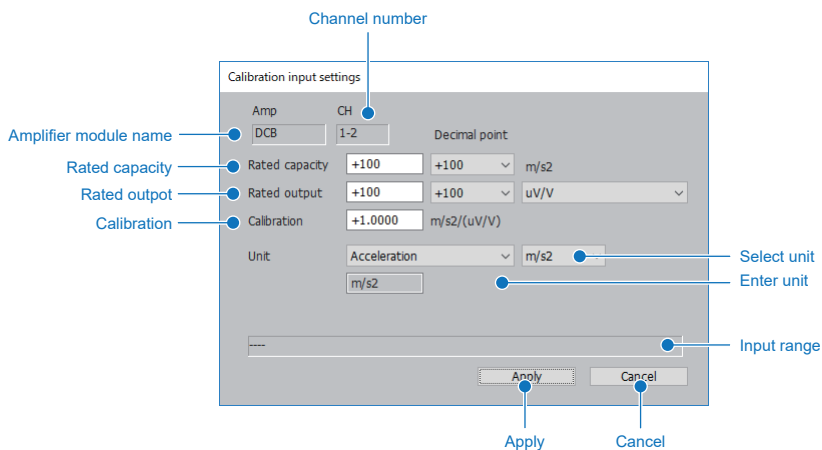

Name	Explanation
Amplifier module name	Displays the names of all module amplifiers that are being configured.
Channel number	Displays the input signal's module number and channel number. [Module Number]-[Channel Number]
Rated capacity	Enter the rated capacity value and the decimal point position. Calculate the calibration coefficient from rated capacity and rated output. Alternatively, calculate the rated output from the rated capacity and the calibration coefficient. Please input while checking the calibration table.
Rated output	Enter the rated output value, the decimal point position, and the unit. Available units: $\mu\text{V/V}$, mV/V , μST (1×10^{-6} strain)
Calibration	Input the calibration coefficient.

Select unit	Select the unit.
Enter unit	Input the unit. Up to 8 half-width characters are allowed.
Input range	Display input range.
Apply	Confirm the settings.
Cancel	Cancel and close input information.

When DC voltage and resistance are used

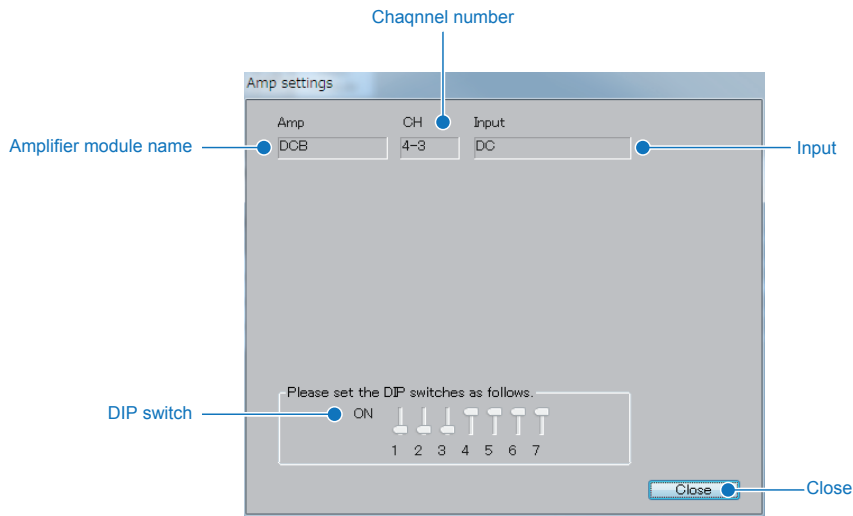

Name	Explanation
Amplifier module name	Displays the names of all module amplifiers that are being configured.
Channel number	Displays the input signal's module number and channel number. [Module number]-[Channel number]
Input	Displays the settings have been input.
DIP switch	Set the DIP switch on the DC Strain Module in accordance with the sensor settings.
Close	Closes the menu.

- Other settings

Set the other settings. The settings vary depending on the input state.

When the strain gauge or strain sensor is used

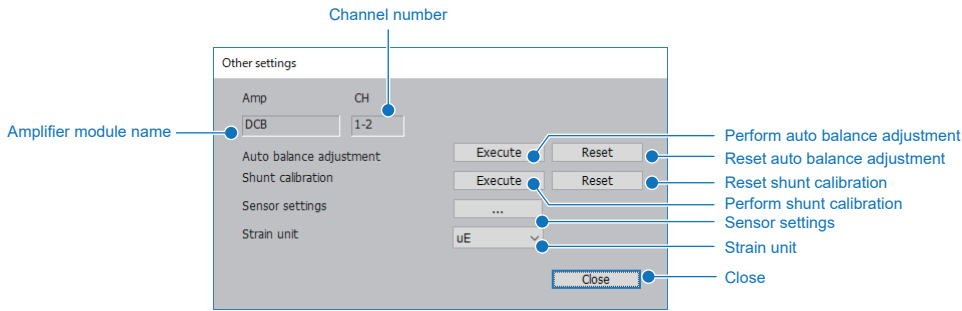

Name	Explanation
Amplifier module name	Displays the names of all module amplifiers that are being configured.
Channel number	Displays the input signal's module number and channel number. [Module Number]-[Channel Number]
Perform auto balance adjustment	Starts the auto-balancing.
Reset auto balance adjustment	Resets the auto-balancing.
Perform shunt calibration	Starts the shunt calibration. The shunt calibration is used for: Quarter bridge: 3 wires, 4 wires Half bridge: 4 wires when the strain gauge is set.
Reset shunt calibration	Resets the shunt calibration.
Sensor settings	Open the Sensor Setting menu.
Strain unit	Modify the unit of the strain. uE, mV/V
Close	Closes the screen.

When DC voltage and resistance are used

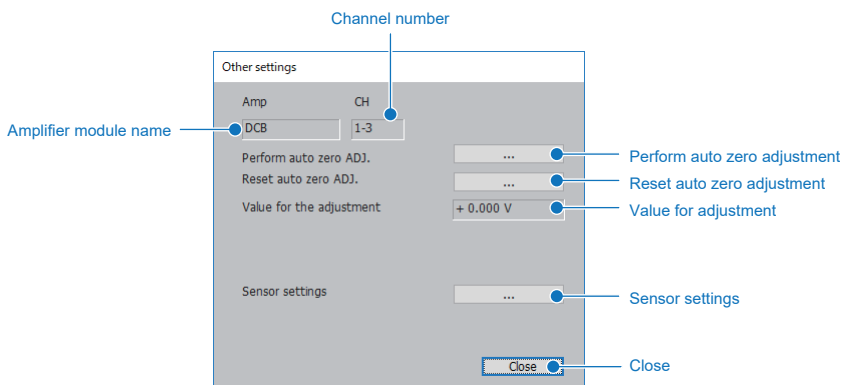

Name	Explanation
Amplifier module name	Displays the names of all module amplifiers that are being configured.
Channel number	Displays the input signal's module number and channel number. [Module Number]-[Channel Number]
Perform auto zero adjustment	To perform zero-point automatic adjustment.
Reset auto zero adjustment	To delete the zero-point voltage value.
Value for the adjustment	Displays the adjusted voltage value.
Sensor settings	Open the Sensor Setting menu.
Close	Closes the screen.

Bulk auto balance adjustment

With the ALL button, auto balancing can be performed in bulk for distortion unit channels the GL7000 is equipped with.

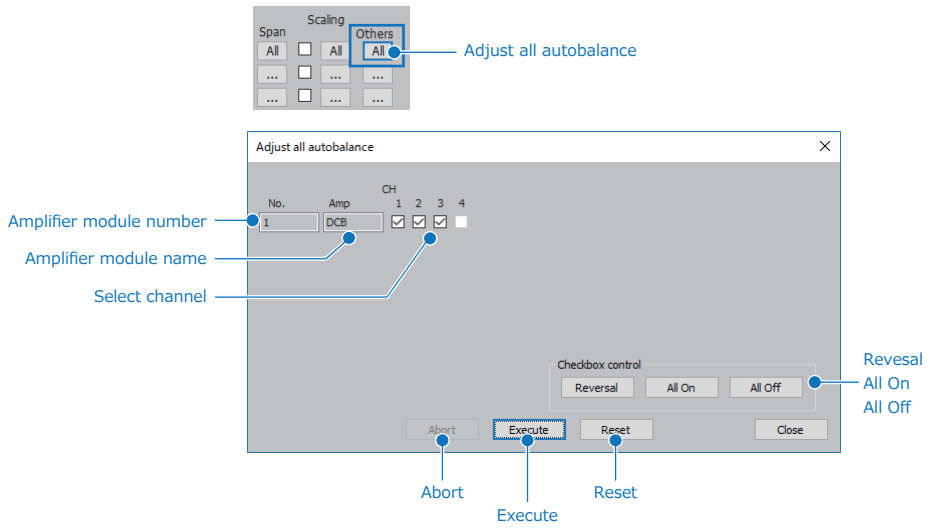

Name	Explanation
Amplifier module number	Displays the number of module amplifier
Amplifier module name	Displays the names of all module amplifiers that are being configured.
Select channel	Channels marked with a check will be subject to auto balancing.
Reversal	Inverts the checked status of selected channels.
All On	Places a check in the channel selection of all channels.
All Off	Removes the check from the channel selection of all channels.
Abort	Cancel bulk auto balance adjustment.
Execute	Executes bulk auto balance adjustment.
Reset	Resets the auto balance adjustment.
Close	Closes the screen.

15-2-4. Amplifier Setting tab: Charge Module

Set the Amplifier tab when the Charge Module is used.

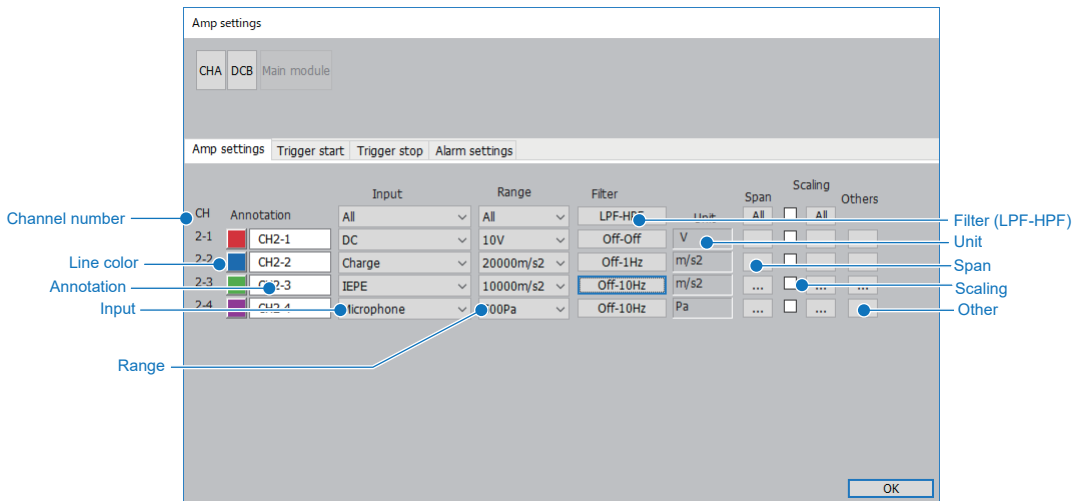

Name	Explanation
Amplifier module name	Displays the input signal's module number and channel number. [Module number]-[Channel number]
Line color	Set the waveform color for each channel.
Annotation	The signal name can be arbitrarily entered to the each channel.
Input	Select the input. The selected value varies depending on the type of device and amplifier module. For details, refer to GL7000 User's Manual.
Range	Select the input range. The selected value varies depending on the type of device and amplifier module. For details, refer to GL7000 User's Manual.
Filter (LPF-HPF)	Select the filter. The selected value varies depending on the type of device and amplifier module. For details, refer to GL7000 User's Manual.
Unit	Displays the unit.
Span	Set the upper and lower limit values for the signal displayed in Waveform Window.
Scaling	Converts the unit. The 4-point setting for the voltage input and the offset for the temperature input can be set. * When CSV file playback is forced to On.
Other	Set the other settings.

* WARNING

When the voltage signal is set, change the input setting to DC, AC, DC-RMS, AC-RMS.

If IEPE is set, the power voltage for driving the sensor from the BNC connector is applied. This power voltage may damage the modules and object to measured

- Filter (HPF-LPF)

Set the HPF (high pass filter) and LPF (low pass filter).

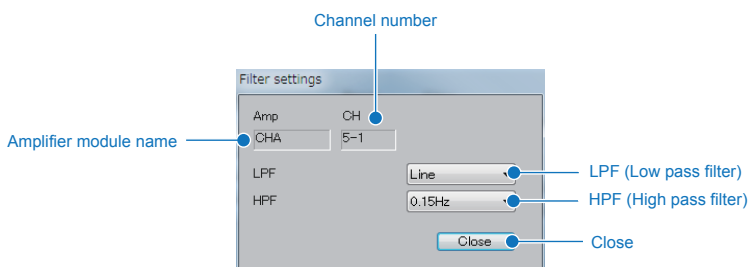

Name	Explanation
Amplifier module name	Displays the names of all module amplifiers that are being configured.

Channel number	Displays the input signal's module number and channel number. [Module number]-[Channel number]
LPF (low pass filter)	Set the LPF (low pass filter).
HPF (high pass filter)	Set the HPF (high pass filter).
Close	Closes the screen.

• **Engineering Settings**

Setting is done by inputting the upper and lower values of both the input side and the conversion side. It is possible to set 2-point offset during temperature input.

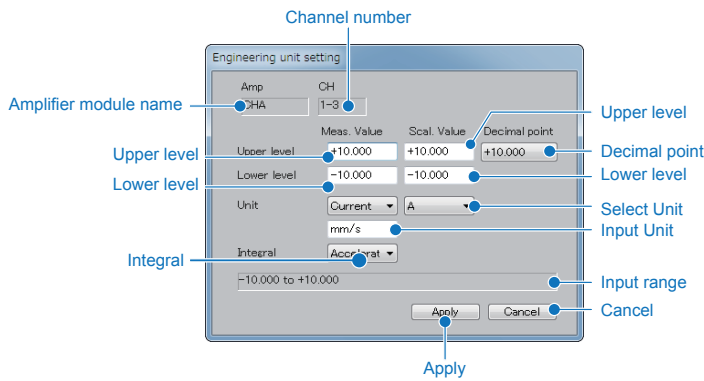

Name	Explanation
Amplifier module name	Displays the names of all module amplifiers that are being configured.
Channel number	Displays the input signal's module number and channel number. [Module number]-[Channel number]
Measured value (Upper/Lower)	To set the upper value/lower value of the original value. There is not difference between the upper value/lower value during temperature input.
Scaling value (Upper/Lower)	To set the post-conversion upper value/lower value. There is not difference between the upper value/lower value during temperature input.
Decimal point	Set decimal point position on output side.
Select Unit	Select the unit.
Input Unit	To input the post-conversion unit. Up to a maximum of 8 characters can be entered.
Integral	Perform the integral calculation for the signal. Acceleration/velocity/displacement
Input range	Display input range.
Apply	Transmits entered values to the main module.
Cancel	Cancel and close input information.

• **Other Settings**

Set the other settings. The settings vary depending on the input state.

DC, AC, DC-RMS, AC-RMS

This is the same as the voltage-type amplifier.

Charge, Charge-RMS

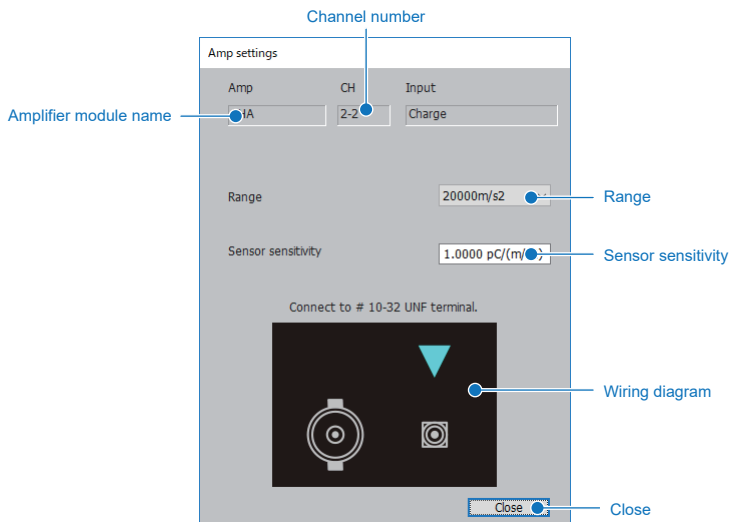

Name	Explanation
Amplifier module name	Displays the names of all module amplifiers that are being configured.
Channel number	Displays the input signal's module number and channel number. [Module number]-[Channel number]
Range	Set the range.
Sensor sensitivity	Set the sensor sensitivity. 0.0001 pC to 100.0000 pC (m/s ²)
Wiring diagram	Connect up the connectors according to the wiring diagram.
Close	Closes the screen.

IEPE, IEPE-RMS

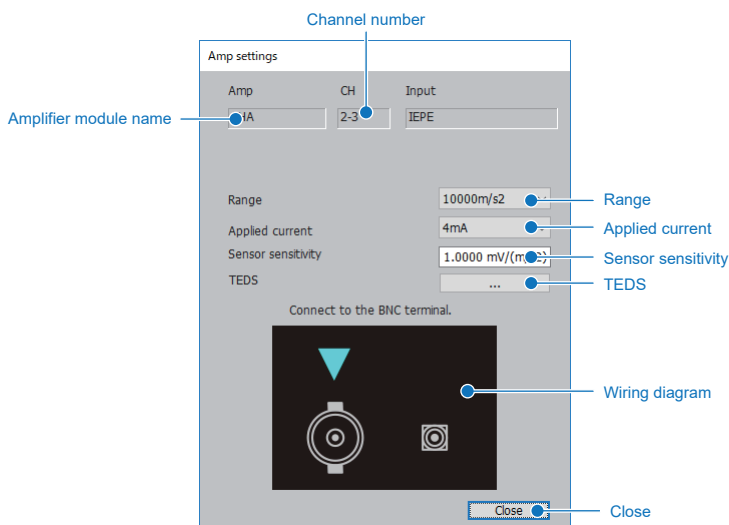

Name	Explanation
Amplifier module name	Displays the names of all module amplifiers that are being configured.
Channel number	Displays the input signal's module number and channel number. [Module number]-[Channel number]
Range	Set the range.
Applied current	Set the applied current. The Voltage and V-RMS only can be set. 4/8 (mA)
Sensor sensitivity	Set the sensor sensitivity. 0.0001 mV to 100.0000 mV (m/s ²)
TEDS	Open the TEDS menu.
Wiring diagram	Connect up the connectors according to the wiring diagram.
Close	Closes the screen.

Microphone

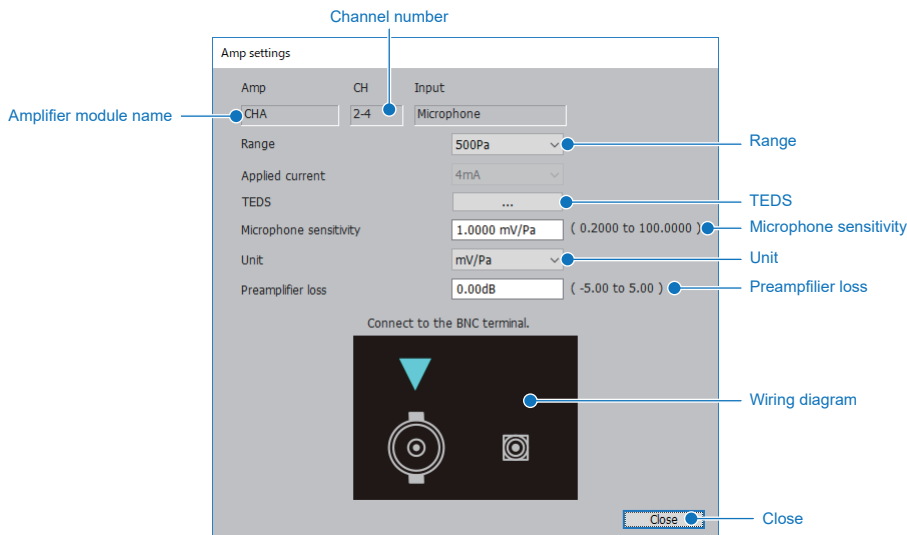

Name	Explanation
Amplifier module name	Displays the names of all module amplifiers that are being configured.
Channel number	Displays the input signal's module number and channel number. [Module number]-[Channel number]
Range	Set the range.
TEDS	Open the TEDS menu.
Microphone sensitivity	Set the microphone sensitivity. mV/Pa: 0.2000 to 100.0000 (mV/Pa) dB re. 1V/Pa: -73.98 to -20.00(dB)
Unit	Select the microphone sensitivity input unit. mV/Pa dB re. 1V/Pa
Preamplifier loss	Enter the preamplifier loss. -5.00 to 5.00(dB)
Wiring diagram	Connect up the connectors according to the wiring diagram.
Close	Closes the screen.

15-2-5. Amplifier Setting tab: Logic/Pulse Module

To set amplifier tab during Logic/Pulse Modules. The setting screen changes with the switch of Logic/Pulse.

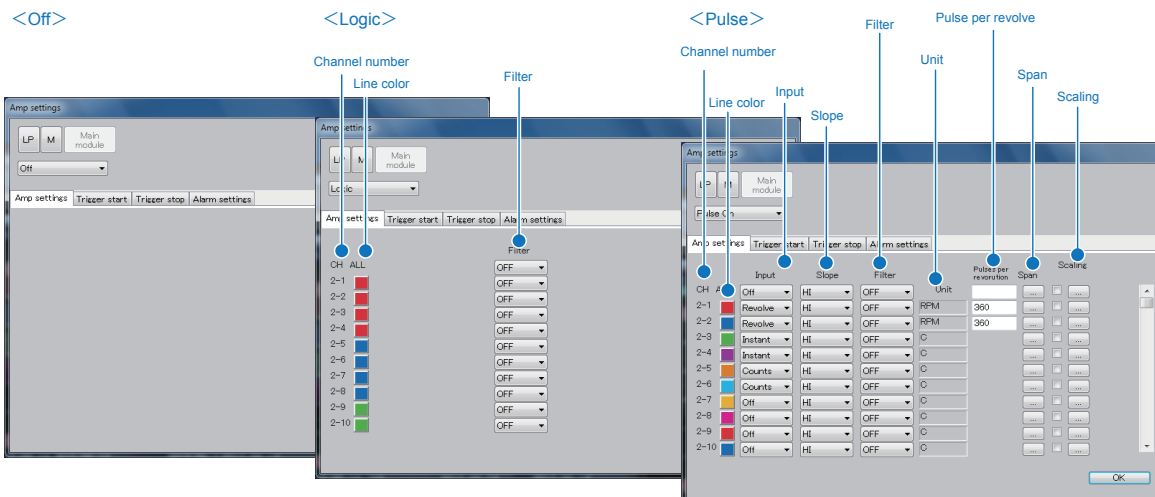

- **When Off Setting**

Logic/Pulse is set as Off. Nothing will be displayed.

- **When Logic Setting**

The logic pulse setting is set to logic.

Name	Explanation
Channel number	Displays the input signal's module number and channel number. GL7000: [Module number]-[Channel number] GL860, GL260, GL840, GL240, GL980, GL2000 and GLT400 : [Channel number]
Line color	It is possible to set the waveform color. Depending on the connected device, some devices might not save the waveform color to the main module. If this occurs, the waveform color will reverted to the default color.
Filter	To select a filter. There may be difference in the selection value depending on the type of machine or amplifier module. For more details, refer to the main module's User's Manual.

- **Pulse Setting**

The Pulse Setting is automatically set to Logic Pulse defaults

Name	Explanation						
Channel number	Displays the input signal's module number and channel number. GL7000: [Module number]-[Channel number] GL860, GL260, GL840, GL240, GL980, GL2000 and GLT400 : [Channel number]						
Line color	It is possible to set the waveform color. Depending on the connected device, some devices might not save the waveform color to the main module. If this occurs, the waveform color will reverted to the default color.						
Input	<table border="1"> <tr> <td>Revolve</td> <td>Pulses generated per minute will be counted.</td> </tr> <tr> <td>Counts</td> <td>Will estimate and count the generation of internal sampling pulses.</td> </tr> <tr> <td>Instant</td> <td>Will count the generation of internal sampling pulses.</td> </tr> </table>	Revolve	Pulses generated per minute will be counted.	Counts	Will estimate and count the generation of internal sampling pulses.	Instant	Will count the generation of internal sampling pulses.
Revolve	Pulses generated per minute will be counted.						
Counts	Will estimate and count the generation of internal sampling pulses.						
Instant	Will count the generation of internal sampling pulses.						
Slope	<table border="1"> <tr> <td>High</td> <td>Tallies signal build-up.</td> </tr> <tr> <td>Low</td> <td>Tallies signal decay.</td> </tr> </table>	High	Tallies signal build-up.	Low	Tallies signal decay.		
High	Tallies signal build-up.						
Low	Tallies signal decay.						
Filter	Setting the pulse filter. The filter conforms approximately -3dB at 30Hz.						
Unit	Displays the unit.						
Pulse per revolve.	Set the number of pulses in a single rotation. Available for input only when under "Number of Rotations". (GL7000 only)						
Span	Setting the pulse span. Please refer to the analog amplifier span.						
Scaling	Unit conversion. Refer to the analog amplifier scaling. * When CSV file playback is forced to On.						

15-2-6. Amplifier Setting tab: Voltage Output Module

To set amplifier tab during the Voltage Output Modules. (GL7000 only)

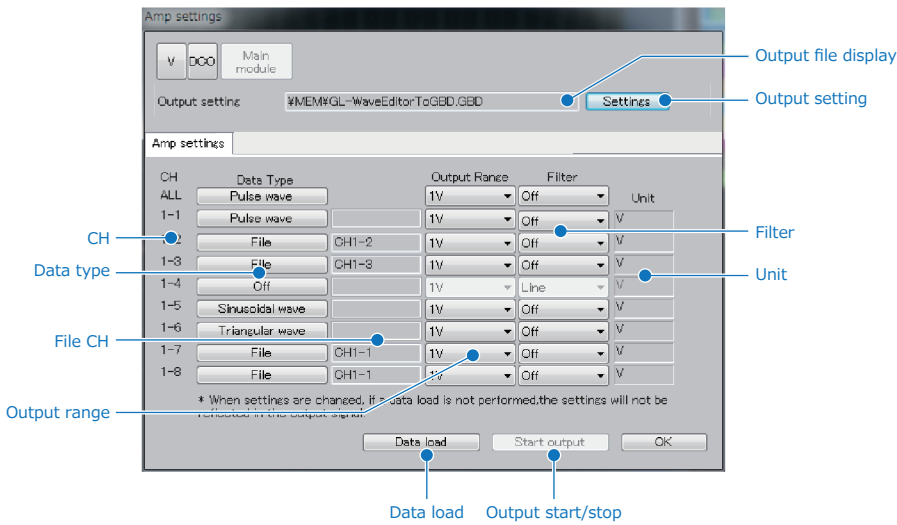

Name	Explanation
Channel number	Displays the input signal's module number and channel number. [Module number]-[Channel number]
Data type	Set the data type to be output.
Output range	Select the output range.
File CH	When the data type is set to Data file, the number of channels for the data file is displayed
Output file display	Select the filter.
Output setting	Set the output file and associated items.
Unit	Display the unit.
Data load	Transfer the data to the Voltage Output Module in the GL7000.
Output start / Output stop	Start or stop the signal output from the Voltage Output Module in the GL7000.

* The CSV waveform editing macro "GL-WaveEditor" supplied with this software generates the wave (Sinusoidal wave or Triangular wave) using the CSV file recorded by this software and GL7000. The GL-WaveEditor can be found in "My Documents" → "Graphtec" → "GL-Connection" → "Temp". Microsoft EXCEL (Office 2003 or later) must be installed.

• Output setting

Set the output file and associated operation controls.

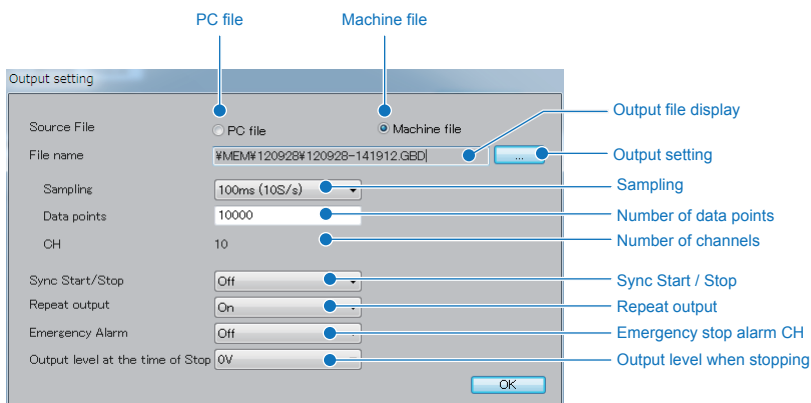

Name	Explanation
PC file	Select when outputting the file in the PC.
Machine file	Select when outputting the file in the GL machine module.

Output file display	Display the file name to be output.
Sampling	Display the sampling interval of the file displayed in the output file. The sampling of the signal to be output to the Voltage Output Module can be changed.
Number of data points	Display the number of data points of the file displayed in the output file. Set the number of signal points to be voltage output to the Voltage Output Module.
Number of channels	Display the number of channels of the file displayed in the output file.
Sync Start / Stop	The signal output from the Voltage Output Module is started at the same time as the recording start. The signal output from the Voltage Output Module is stopped when stopping the recording.
Repeat output	When the outputs of number of data points are completed, set whether repeatedly outputting from the beginning of the data or not.
Emergency stop alarm CH	When the alarm occurs, set whether stopping the signal output from the Voltage Output Module or not.
Output level when stopping	When the output is stopped, set whether retaining the signal level at that time or switching to 0 levels.

• **Output CH setting**

Set the channel that transfers the data to the Voltage Output Module.

Data type: Off

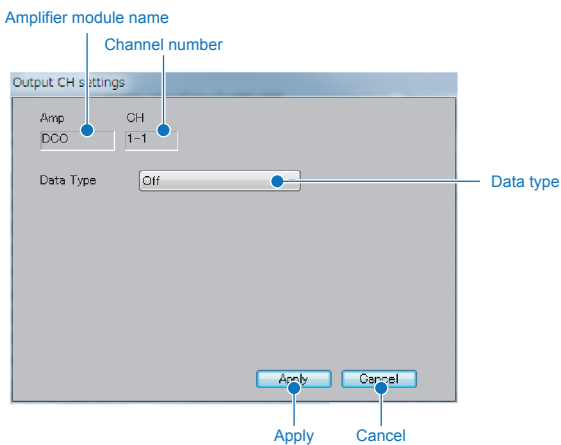

Name	Explanation
Amplifier module name	Displays the names of all module amplifiers that are being configured.
Channel number	Display the module number and channel number. [Module number]-[Channel number]
Data type	Set the data type to be output. Off, Data file, DC, Sinusoidal wave, Triangular wave, Ramp wave, Pulse wave

Data type: Data file

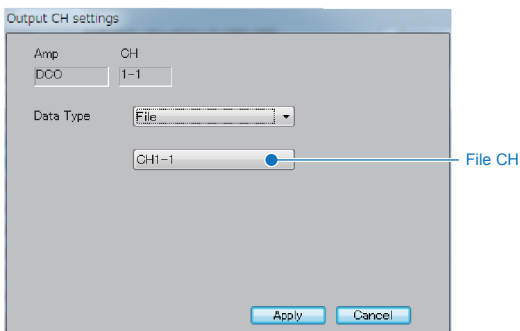

Name	Explanation
File CH	When the data type is set to Data file, select which channel in the data file is output.

Data type: DC

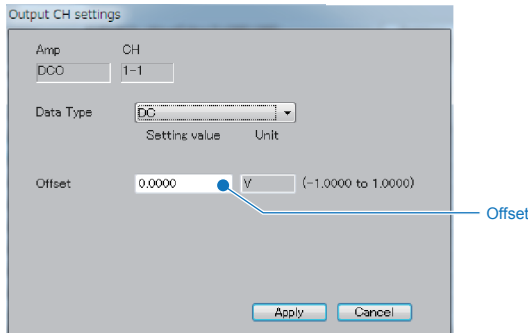

Name	Explanation
Offset	Set the offset (Range: Within the (±) setting range).

Data type: Sinusoidal wave, Triangular wave, Ramp wave

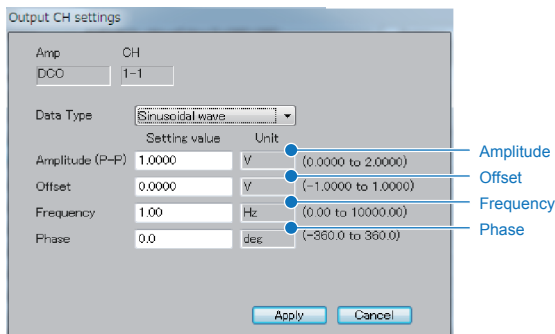

Name	Explanation
Amplitude	Set the amplitude (P-P) (Max. value: up to 2 times of the setting range). (Example) Amplitude 1V: +0.5 to -0.5
Offset	Set the offset (Range: Within the (±) setting range).
Frequency	Set the frequency (Range: 0.00 to 10000.00 Hz). Approx. 1/10 cycle of the sampling interval is a criteria. (Example) Sampling 1ms (1kHz): 0 to 100Hz
Phase	Set the phase (Range: ±0.0 to 360.0 deg.).

Data type: Pulse wave

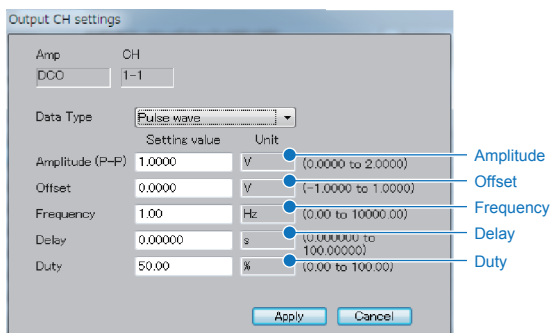

Name	Explanation
Amplitude	Set the amplitude (P-P) (Max. value: up to 2 times of the setting range). (Example) Amplitude 1V: +0.5 to -0.5
Offset	Set the offset (Range: Within the (±) setting range).
Frequency	Set the frequency (Range: 0.00 to 10000.00 Hz). Approx. 1/10 cycle of the sampling interval is a criteria. (Example) Sampling 1ms (1kHz): 0 to 100Hz
Delay	Set the delay (Range: 0.00000 to 100.00000 sec.).
Duty	Set the duty (Range: 0.00 to 100.00%).

- Signal waveform generated

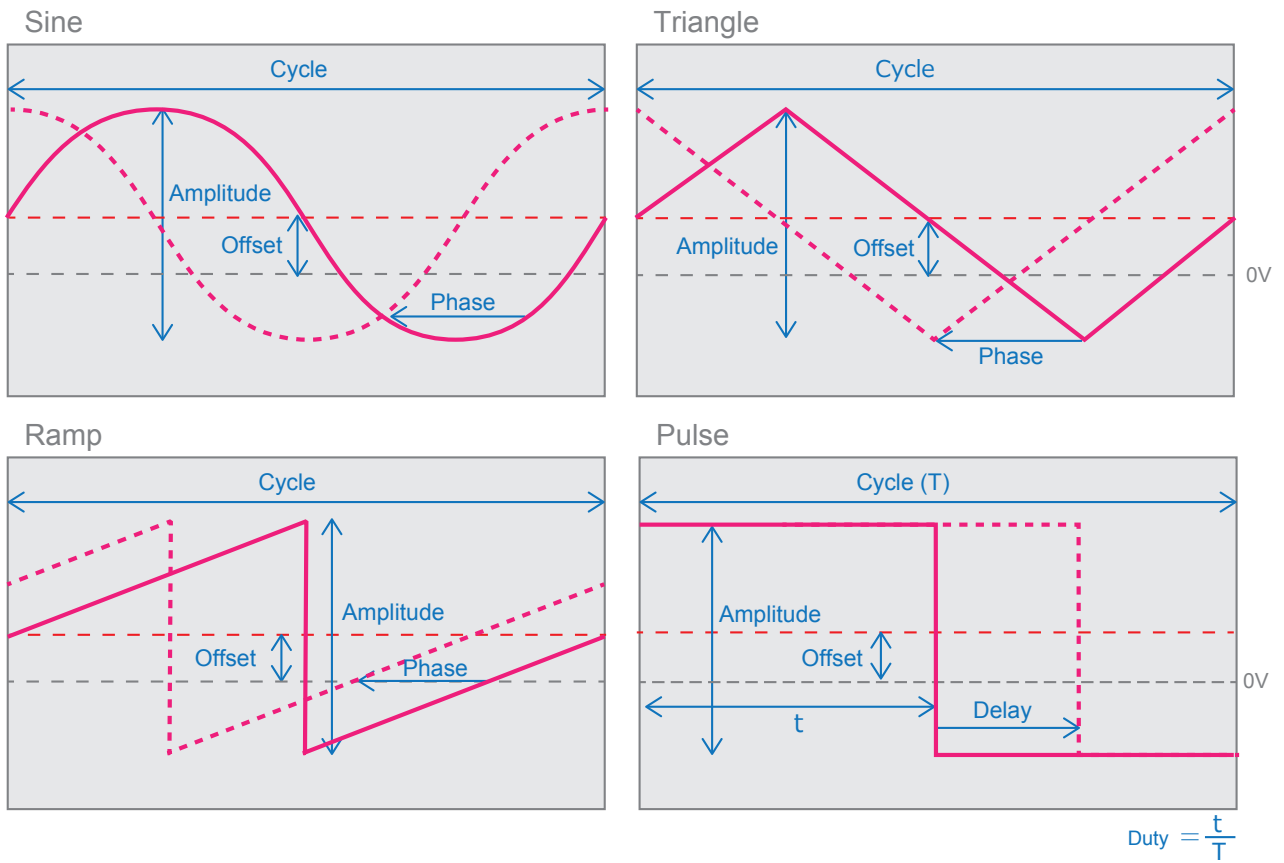

15-2-7. Amplifier Setting tab: GL860, GL260, GL240, GL840, GLT400, each digital sensor / Wireless sensor / Remote terminal

To set amplifier tab during the GL860, GL260, GL240, GL840 and GLT400.

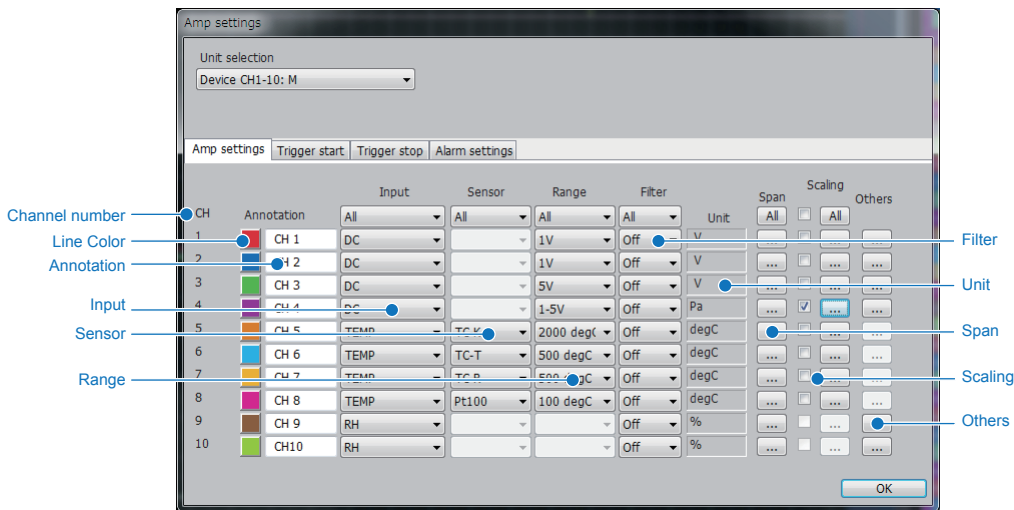

Name	Explanation
Channel number	Displays the input signal's module number and channel number. GL860, GL260, GL240, GL840, GLT400: [channel number] GS sensor: GS[number] WL sensor: WL[unit number]-[channel number] RT sensor: RT[unit number]-[channel number] (*GL840 only)
Line color	It is possible to set the waveform color. (* The line color changing function is not provided in the GL860, GL260, GL240, GL840)
Annotation	It is possible to input signal names to each channel. Up to a maximum of 31 characters can be entered.
Input	To select input. There may be difference in the selection value depending on the type of machine or amplifier module. For more details, please refer to the main module's user's manual.
Sensor	Select a sensor when setting a temperature. The selection values vary depending on the amplifier module. For details, see the instruction manual of the main device.
Range	To select the input range. There may be difference in the selection value depending on the type of machine or amplifier module. For more details, please refer to the main module's user's manual.
Filter	To select a filter. There may be difference in the selection value depending on the type of machine or amplifier module. For more details, please refer to the main module's user's manual.
Unit	Displays the unit.
Span	To set the upper value and lower value of the signal displayed in the waveform window.
Scaling	Unit conversion. When the voltage input is set to 4-point, it is possible to set the temperature input as offset. * When CSV file playback is forced to On.
Others	To set the other.

• Setting of AC clamp mode

When the AC current sensor (GS-DPA-AC) is connected, configure AC clamp mode.

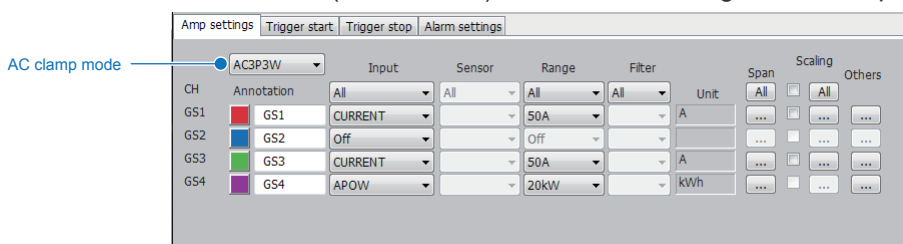

Name	Explanation
AC clamp mode	Configure AC clamp mode.
AC1P2W	Configure to measure AC1-2W. Power = measured current x voltage x power factor
AC1P3W	Configure to measure AC1-3W. Power = (measured current (ch1)) + measured current (ch2)) x voltage x power factor
AC3P3W	Configure to measure AC3-3W. Power = (measured current (ch1)) + measured current (ch2)/2) x voltage x $\sqrt{3}$ x power factor

• **Other settings**

Setting of the accumulated temperature when the temperature/humidity sensor is connected

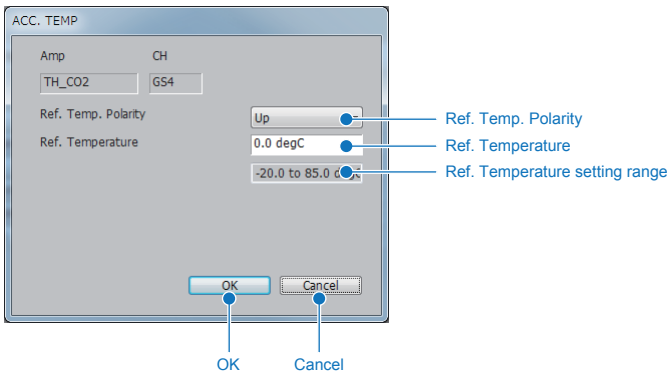

Name	Explanation
Ref. Temp. Polarity	Configure Ref. Temp. Polarity Top: Measured value-Ref. Temperature Bottom: Ref. Temperature-Measured value (* If the calculated value is a negative value, it is converted with 0)
Ref. Temperature	Configure the Ref. Temperature.
Ref. Temperature setting range	The Ref. Temperature setting range is displayed.
OK	Confirm the settings.
Cancel	Closes the screen.

Setting of calibration when the CO2 sensor (GS-CO2) is connected

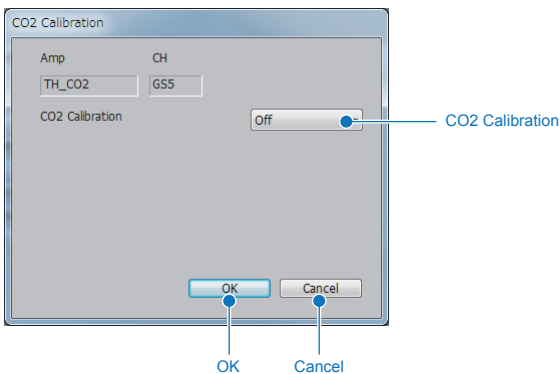

Name	Explanation
CO2 calibration	Configure CO2 sensor calibration. Calibration corrects the minimum value in a specified period against the reference value. This is effective in an environment where the CO2 density is low.
OK	Confirm the settings.
Cancel	Closes the screen.

Setting of voltage and power factor when the AC current sensor (GS-DPA-AC) is connected

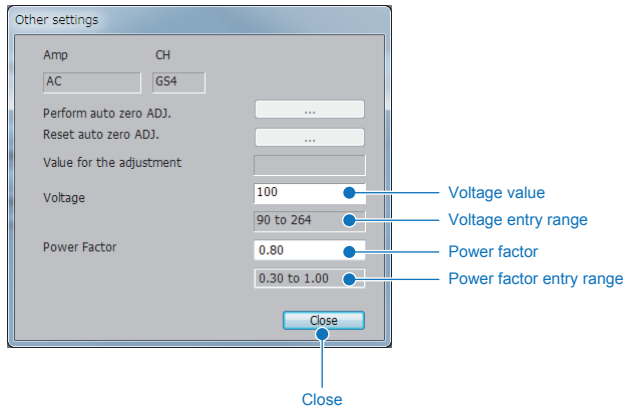

Name	Explanation
Voltage value	Configure the voltage value to calculate power.
Voltage entry range	The voltage entry range is displayed.
Power factor	Configure the power factor to calculate power.
Power factor entry range	The power factor entry range is displayed.
Close	Closes the screen.

15-2-8. Trigger-start/stop Setting Tab

Setting the trigger level for each channel.

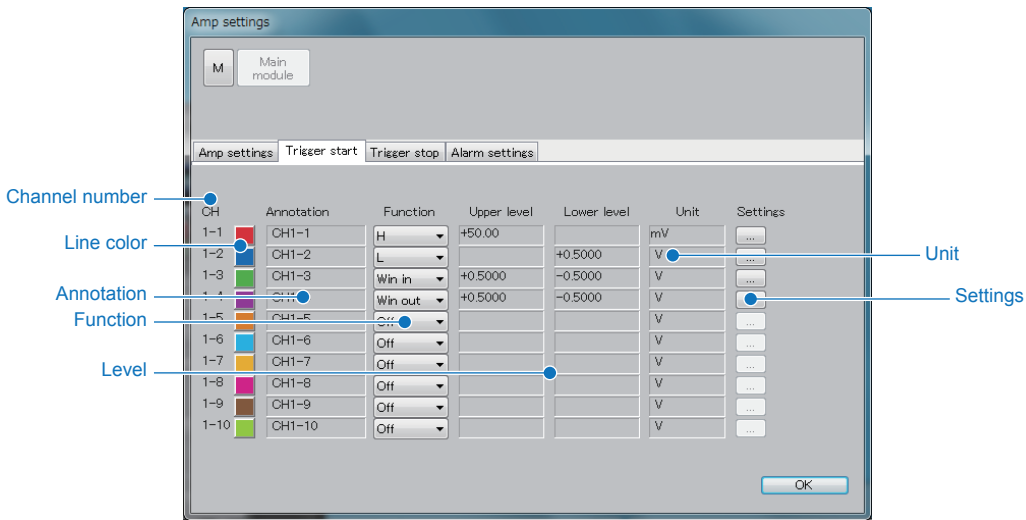

Name	Explanation										
Channel Number	Displays the input signal's module number and channel number. GL7000: [Module number]-[Channel number] GL860, GL260, GL240, GL840, GL980, GL2000 and GLT400: [Channel number]										
Line Color	Displays the waveform color for each channel.										
Annotation	Displays the annotation for each channel.										
Function	<table border="1"> <tbody> <tr> <td>Off</td> <td>Is invalid</td> </tr> <tr> <td>High</td> <td>A trigger will activate in response to an input signal exceeding it's set level.</td> </tr> <tr> <td>Low</td> <td>A trigger will activate in response to an input signal falling below it's set level.</td> </tr> <tr> <td>Window In</td> <td>A trigger will activate in response to the input signal falling inside it's set level.</td> </tr> <tr> <td>Window Out</td> <td>A trigger will activate in response to the input signal falling outside it's set level.</td> </tr> </tbody> </table>	Off	Is invalid	High	A trigger will activate in response to an input signal exceeding it's set level.	Low	A trigger will activate in response to an input signal falling below it's set level.	Window In	A trigger will activate in response to the input signal falling inside it's set level.	Window Out	A trigger will activate in response to the input signal falling outside it's set level.
Off	Is invalid										
High	A trigger will activate in response to an input signal exceeding it's set level.										
Low	A trigger will activate in response to an input signal falling below it's set level.										
Window In	A trigger will activate in response to the input signal falling inside it's set level.										
Window Out	A trigger will activate in response to the input signal falling outside it's set level.										
Level	Displays the level setting.										
Unit	Displays the unit.										
Settings	Displays a screen for setting upper and lower limits.										

* CSV file data during playback do not see the value.

• Trigger-level Setting

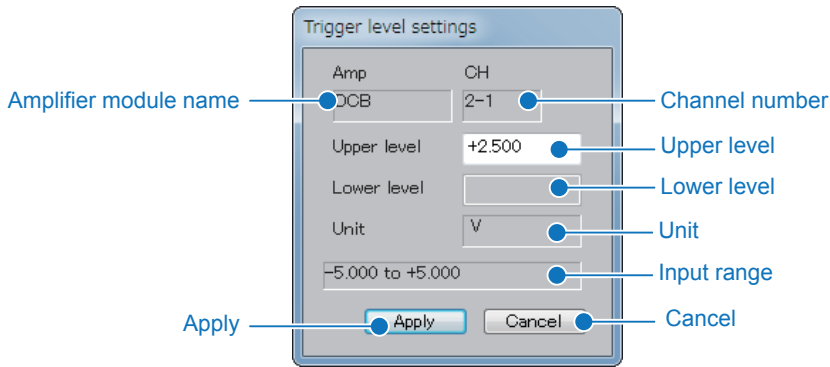

Name	Explanation
Amplifier module name	Displays the names of all module amplifiers that are being configured.
Channel number	Displays the input signal's module number and channel number. GL7000: [Module number]-[Channel number] GL860, GL260, GL240, GL840, GL980, GL2000 and GLT400: [Channel number]
Upper level (input range)	Inputs during build-up setting, and Window In/Out setting. Displays the setting range of the input within the ().
Lower level (input range)	Inputs during decay setting, and Window In/Out setting. Displays the setting range of the input within the ().
Unit	Displays the unit.
Input range	Display input range.
Apply	Transmits entered values to the main module.
Cancel	Cancel and close input information.

15-2-9. Alarm Setting Tab

Setting the alarm level for each channel.

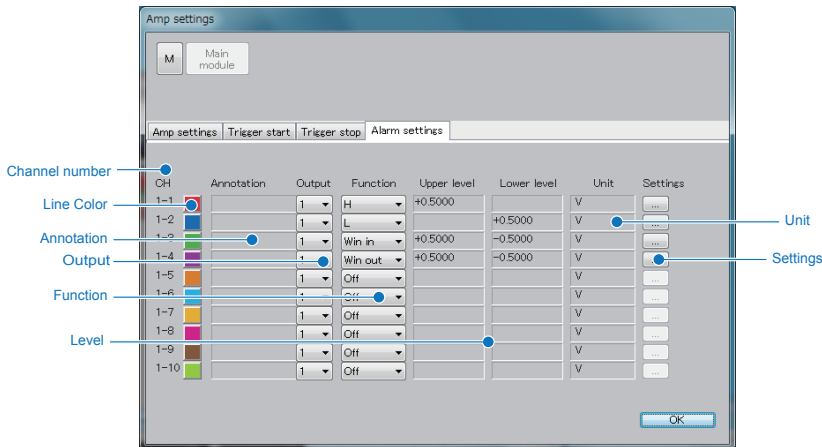

Name	Explanation										
Channel number	Displays the input signal's module number and channel number. GL7000: [Module number]-[Channel number] GL860, GL260, GL240, GL840, GL980, GL2000 and GLT400: [Channel number]										
Line color	Displays the waveform color for each channel.										
Annotation	Displays the annotation for each channel.										
Output	Displays the alarm module's output channel. If multiple channels are set to the same number, the unit will output as <1> or <2>										
Function	Comparative mode will be set to each channel's alarm level. Set combinations for conditional level triggers for each channel. <table border="1" data-bbox="389 1077 1398 1223"> <tbody> <tr> <td>Off</td> <td>Alarm is not set to channel.</td> </tr> <tr> <td>High</td> <td>An alarm will activate in response to the set input signal exceeding its level.</td> </tr> <tr> <td>Low</td> <td>An alarm will activate in response to the set input signal falling below its level.</td> </tr> <tr> <td>Window In</td> <td>An alarm will activate in response to the set input signal internalizing.</td> </tr> <tr> <td>Window Out</td> <td>An alarm will activate in response to an input signal that goes outside its set level.</td> </tr> </tbody> </table>	Off	Alarm is not set to channel.	High	An alarm will activate in response to the set input signal exceeding its level.	Low	An alarm will activate in response to the set input signal falling below its level.	Window In	An alarm will activate in response to the set input signal internalizing.	Window Out	An alarm will activate in response to an input signal that goes outside its set level.
Off	Alarm is not set to channel.										
High	An alarm will activate in response to the set input signal exceeding its level.										
Low	An alarm will activate in response to the set input signal falling below its level.										
Window In	An alarm will activate in response to the set input signal internalizing.										
Window Out	An alarm will activate in response to an input signal that goes outside its set level.										
Level	Displays the level setting.										
Unit	Displays the unit.										
Settings	Displays the screen for setting the upper and lower alarm level limits.										

* CSV file data during playback do not see the value.

• Alarm Level Settings

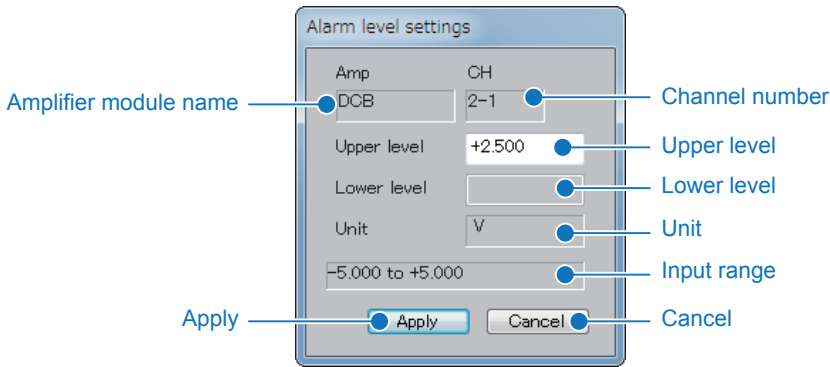

Name	Explanation
Amplifier module name	Displays the names of all module amplifiers that are being configured.
Channel number	Displays the input signal's module number and channel number. GL7000: [Module number]-[Channel number] GL860, GL260, GL240, GL840, GL980, GL2000 and GLT400: [Channel number]
Upper level (input range)	Inputs during rise setting, and Window In/Out setting. Displays the setting range of the input within the ().
Lower level (input range)	Inputs during fall setting, and Window In/Out setting. Displays the setting range of the input within the ().
Unit	Displays the unit.
Input range	Display input range.
Apply	Transmits entered values to the main module.
Cancel	Cancel and close input information.

15-3. Amplifier Batch Display

With version 2.20 or later, it is possible to display a list of settings for units connected to the GL7000. This menu is not displayed on devices other than the GL7000.

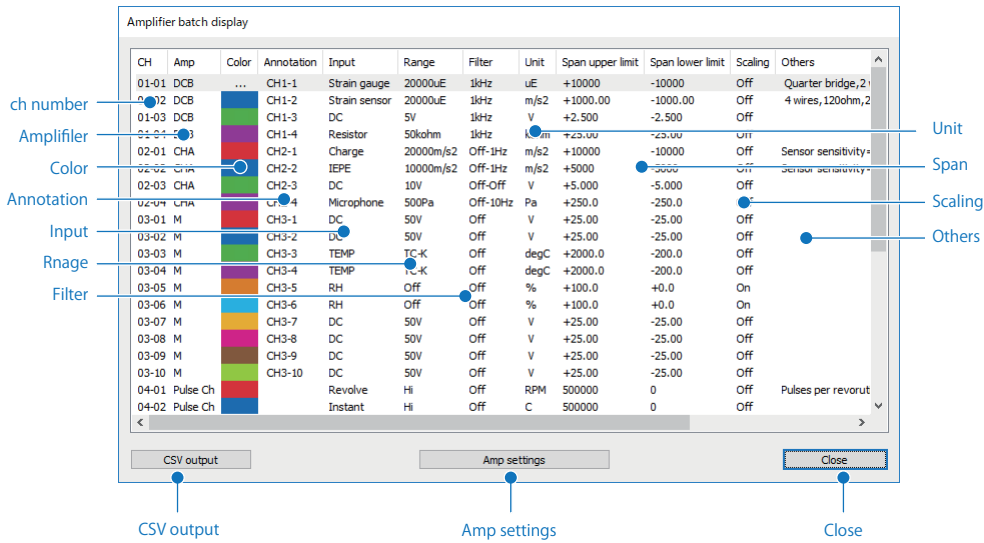

Name	Explanation
ch number	Displays the input signal's module number and channel number. GL7000: [Module number]-[Channel number]
Amplifier	Amp unit type is displayed.
Color	Displays the waveform color for each channel.
Annottion	Displays the annotation for each channel.
Input	Display the input setting.
Rnage	Display the range setting.
Filter	Display the filter setting.
Unit	Display the unit.
Span	The upper and lower limits for the waveform shown in the waveform window are displayed.
Scaling	Displays "On/Off" for the unit conversion function.
Others	Additional information can be displayed depending on connected units and inputs.
CSV output	The displayed list is saved as a CSV file.
Amp settings	The amplifier settings screen for the selected line is displayed.
Close	Close the window.

15-4. Data Settings

Set the sampling, main module recording destination, and method of data recording on the PC.

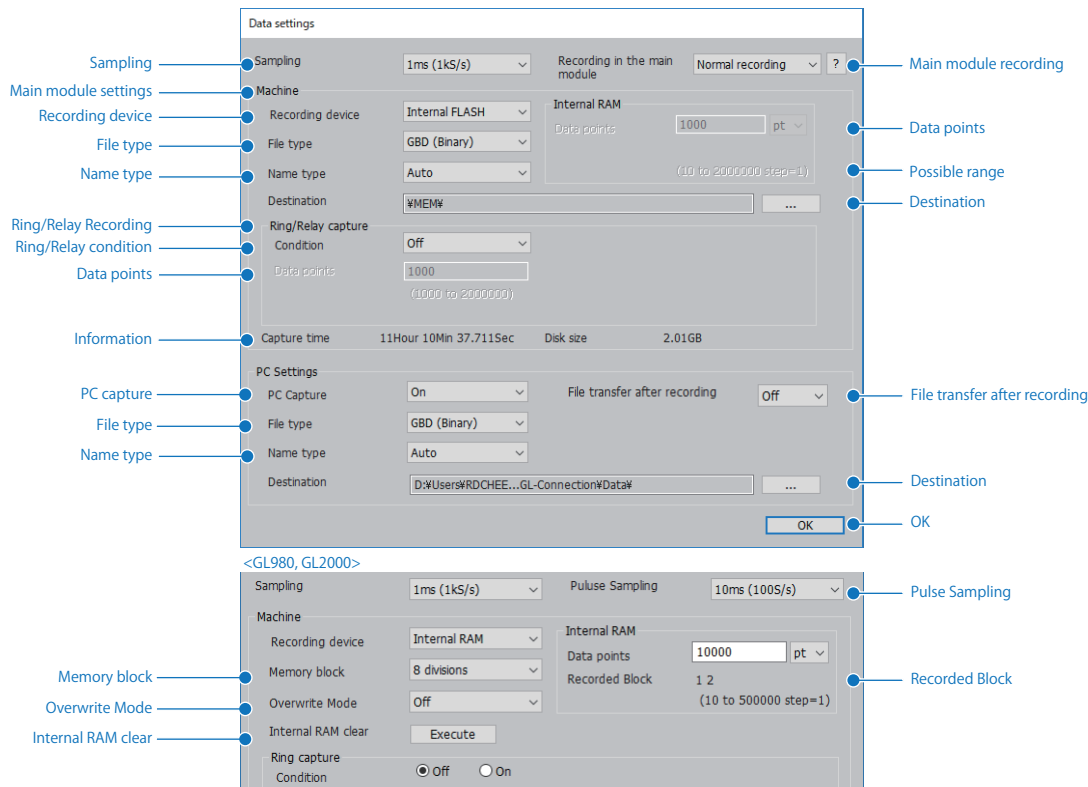

Name	Explanation						
Sampling	Set the data recording intervals. The sampling intervals and connected amplifiers will adjust depending on the number of channel settings and the save-destination of the recording medium. For information, refer to “12-3-1. Sampling limits”. Also, transfers may be incomplete when exceeding sampling limits due to network delays, etc. When recording to PC by connecting to a device in real-time, please confirm the discarded data count under Recording Information Window during free-running mode. When the discarded data is counted, the data is discarded due to incomplete data transfer. If this occurs, please reset the sampling rate to a lower speed.						
Main module settings	Set the option to record the data to the connecting main module.						
Main module recording	<table border="1"> <tbody> <tr> <td>On</td> <td>Saves data to the connecting main module.</td> </tr> <tr> <td>Normal recording</td> <td>Recording uses normal single sampling.</td> </tr> <tr> <td>Dual sampling</td> <td>This function allows recording with both high- and low-speed sampling. (GL7000 version 2.00 or later only)</td> </tr> </tbody> </table>	On	Saves data to the connecting main module.	Normal recording	Recording uses normal single sampling.	Dual sampling	This function allows recording with both high- and low-speed sampling. (GL7000 version 2.00 or later only)
On	Saves data to the connecting main module.						
Normal recording	Recording uses normal single sampling.						
Dual sampling	This function allows recording with both high- and low-speed sampling. (GL7000 version 2.00 or later only)						

Recording devices	Set the recording destination.	
	Internal RAM	Saves to internal RAM. Data saved to the internal RAM will be erased when power to the GL main module is lost. Please set internal RAM when doing high speed recording under 1ms (fastest sampling speed conforms to module). The PC cannot record real-time data during internal RAM setting. (GL7000, GL980, GL2000 only)
	Internal flash	Records onto internal drive. Records sampling slower than 1ms.
	SD card	Records to the external SD card. We ask all our customers to please have your SD card ready. (GL7000, GL980, GL2000, GL860, GL260, GL240, GL840 and GLT400)
	SSD module	Records to the SSD module (128GB) (Option) The PC cannot record real-time data during SSD module recording. (GL7000 only)
	USB memory	Record to the external USB memory. USB memory should be prepared by the customer. (GL980, GL2000 only)
	Off	Data of device is not saved. (GL980, GL2000 only)
Data points	Set the recording data points during Internal RAM setting. You can switch setting for units (Ver.1.60)	
	pt	Set sampling points.
	s	Set seconds.
	ms	Set milliseconds.
	us	Set microseconds.
Possible range	Displays the recording data points range of the Internal RAM.	
File type	Set the format of recorded data.	
	GBD (binary)	Records as our unique binary data. Data can be played back at high speed because the recording size is comparatively smaller than CSV.
	CSV (Text)	Records as text format that can be displayed by Excel, etc. Compared to GBD, the data size is larger and data playback cannot be displayed at high speed.
Name type	Set how to name files.	
	Automatic	Creates dated folders in the designated folder and creates files. (Example: No1_2012-04-04_12-34-56.GBD)
	Unspecified	Set the name of unspecified folders.
	Serial	The file is created in the file name that you entered arbitrarily plus the serial number. (Supported by GL860, GL260, GLT400 and GL840 V1.60 or later)
File transfer after recording	When "On" is selected, the main unit file is automatically transferred when recording stops. When recording repeats, the file is transferred each time a repeat is made. (GL860 and GL260 only)	
Destination	Set the save-destination of the data recorded to the main module.	
Save destination path	Displays the saving destination path.	
Ring/Relay condition	<p>Select off, ring or relay capture.</p> <p>Ring capture captures data while deleting old data when captured points exceed set points.</p> <p>Relay capture captures data while separating files in units of up to 4GB (or 2GB).</p> <p>Memory loop: If the remaining capacity runs out during relay recording, the oldest relay file being recorded is deleted and recording continues. (* Only for GL860 and GL260)</p> <p>Since the setting contents differ depending on the model, refer to the instruction manual of the main device. (Supported by GL7000 V2.00 or later, GL840 V1.44 or later, GL860, GL260 and GLT400)</p>	

Data points	Set recording data points during ring recording. For more details, please refer to the main module's user's manual.	
Possible range	Displays the setting range of the ring recording data points.	
Information	Displays the possible recording time and total remaining disk space at the recording destination.	
PC capture	Sets PC capture on or off.	
	On	PC capture is started.
	Off	PC capture is not started. When turning this off, the main unit recording must be turned on.
PC file type	Set the PC file format. Refer to the file format of the main module.	
PC name type	Set how to name files.	
	Auto	Creates dated folders in the designated folder and creates files. (Example: No1_2012-04-04_12-34-56.GBD)
	User	Set the name of unspecified folders.
PC destination	Set the save-destination of the data recorded to the PC.	
PC save destination path	Displays the saving destination pass.	
OK	Closes the screen.	
Pulse Sampling	When pulses are enabled, it is possible to configure the sampling of pulses separately from the sampling. Pulse sampling must be in a range that is slower than the sampling while also being a multiple of the sampling value.	
Memory Block	When an internal RAM is configured, the internal RAM can be split to perform multiple recordings. Number of splits: No splits / 2 splits / 4 splits / 8 splits *When split, the number of data points that can be recorded will decrease. (1/8 with 8 splits) *Switching the memory block split will clear all of the internal RAM recording data.	
Overwrite Mode	When set to ON when internal RAM is configured, recording will be performed by overwriting the blocks that have already been used for recording. When set to Off, overwriting recording will not be performed.	
Internal RAM clear	When internal RAM is configured, all blocks that have already been used for recording will be cleared.	
Recorded Block	Displays the number of the block that has already been used for recording.	

- **When dual sampling is enabled (GL7000 only)**

The dual sampling function can be utilized when this software is version 2.20 or later and the GL7000 is version 2.00 or later. For more information regarding dual sampling, please refer to "16-5. Dual sampling function (version 2.20 or later)".

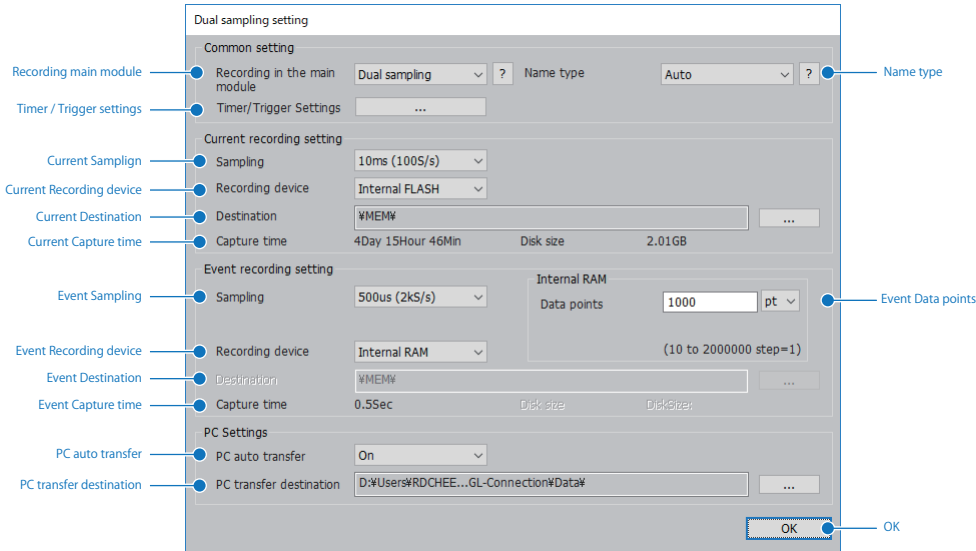

Name	Explanation	
Recording main module	Off	Data will not be saved in the unit.
	Normal recording	Recording uses normal single sampling.
	Dual sampling recording	This function allows recording with both high- and low-speed sampling. (GL7000 version 2.00 or later only)
Name type	Sets the dual sampling file naming convention.	
	Auto	A folder named as the current date is created in the specified folder, and the files are generated within it. ex) Folder name: 181010-001234 Dual sampling file name: 181010-001234.DSA Current file name: 181010-001234.GBD Event file name: 181010-001234_EV001.GBD
User	Set the name of unspecified folders. ex) When the name is "ABCD" Dual sampling file name: ABCD.DSA Current file name : ABCD.GBD Event file name : ABCD_EV001.GBD	
Timer / Trigger settings	Configures the timer and trigger.	
Current Sampling	1/2/5/10/20/50/100/125/200/250/500ms/1/2/5/10/20/30sec/1/2/5/10/20/30min/1hour	
Current Recording device	Set the recording destination	
	Internal flash	Records onto internal drive.
	SD card	Records to the external SD card. We ask all our customers to please have your SD card ready.
Current Destination	Set the save-destination of the data recorded to the main module.	
Current Capture time	Displays the available recording time and disk size.	
Event sampling	1/2/5/10/20/50/100/200/500μs * The maximum sampling rate may vary depending on the configuration of the amplifier unit and inputs.	
Event Data points	Set the recording data points during internal RAM setting.You can switch setting for units. 10 to 2,000,000	
	pt	Set sampling points.
	s	Set seconds.
	ms	Set milliseconds.
	us	Set microseconds.

Event Recording device	Set the recording destination.	
	Internal RAM	Saves to internal RAM. Data saved to the internal RAM will be erased when power to the GL main module is lost.
	SSD unit	Records to the SSD module (128GB) (Option)
Event Destination	Set the save-destination of the data recorded to the main module.	
Event Capture time	Displays the available recording time and disk size.	
PC Auto transfer	Sets whether the recorded data in the main unit is automatically transferred to the PC after dual sampling recording is complete.	
	On	Data is transferred. Please enable this if the high-speed event recording save location is set to the internal RAM. A folder with a time name is automatically generated during PC automatic transfer. The time is the time when transfer started.
	Off	Data is not transferred. When the data is to be transferred at a later time, it is possible to transfer all related files at once by transferring the dual sampling files (*.DAS) on the main unit file generation screen.
PC Transfer destination	Sets the save location for automatic PC transfer.	
OK	Close the window.	

• **Timer / Trigger (GL7000Ver.2.00 or later)**

When the dual sampling function is enabled, it is possible to set the timer and trigger functions separately for current (low-speed) recording and event (high-speed) recording.

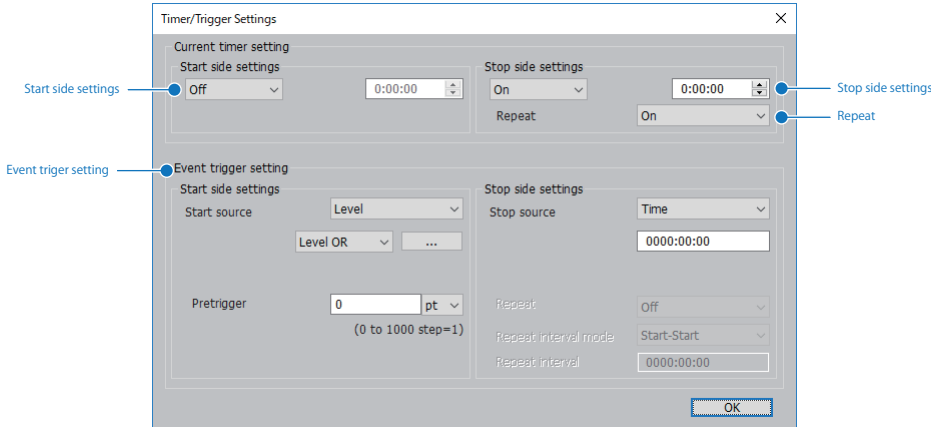

Name	Explanation	
Start side settings	Off	Starts unconditional recording.
	On	Recording starts at the specified hour and minute. * The number of seconds is ignored.
Stop side settings	Off	There are no stop conditions.
	On	Recording stops at the specified hour and minute. * The number of seconds is ignored.
Repeat	Off	Repeat recording is not carried out.
	On	The next recording starts as soon as the stop setting values are reached.
Event trigger setting	This is treated in the same manner as the trigger settings for normal recording. * Repeat recording is disabled if the internal RAM is set as the high-speed (event) recording save location.	

15-4-1. Sampling Limits

High speed sampling is limited by the number of recording channels, connected modules, and the recording destination, etc. Even within the following limits, transmission may be incomplete due to transmission delays with multiple module connections, especially with LAN connections. If this occurs, please reduce the sampling rate. For more details on the GL device limits, please refer to the main module user's manual on CD-ROM.

- **GL7000**

Name	Explanation		
Module-based limits (GL device limits)	Voltage module	1 ms	
	Voltage / Temperature module	10 ms	
	High Speed Voltage / High Voltage module	1 us	
	DC Strain / Charge module	10 us	
	Logic / Pulse module	Logic: 1 us / pulse: 100 us	
Recording destination-based limits (GL device limits)	Internal RAM	1 us	
	Internal flash	1 ms	
	SD card	1 ms	
	SSD module	1 to 2 modules: 1 us; however, the pulse runs only until 8ch 3 to 4 modules: 2 us; however, the pulse is only until 8ch 5 to 10 modules: 5 us; however, the pulse is only until 16ch 10 us or later; the pulse is only until 32ch	
Main module recording format-based limits (GL device limits)	GBD (binary)	1 us	
	CSV (Text)	10 ms	
Ring recording-based limit. (GL device limits)	Ring recording-based limit. (GL device main module limits) When ring recording is on: 100ms (Only when Internal Flash, SD card, SSD module)		
Calculation function-based limits (GL device limits)	100 ms * The GL device's calculation function cannot be used with this application. There is no calculation function in this application.		
Transmission-based limits (Application limits)	There are estimated sampling settings for PC recording depending on the volume of data communication.		
	* When connecting through an existing network such as a LAN connection, communication may not be possible within the following limits. In such a case, please use a USB connection, or set a lower sampling rate.		
	Estimated sampling rates		
	USB connection	GBD (binary) format	1 ms / 5 module (*)
		CSV (text) format	1 ms / 5 module (*)
	LAN connection	GBD (binary) format	1 ms / 5 module (*)
CSV (text) format		1 ms / 5 module (*)	

• **GL260, GL240, GL840 and GLT400**

Name	Explanation	
Limitations by amplifier (Limitations of the GL module side)	Number of CH available	Fastest sampling
	1	10 ms
	2	20 ms
	3 to 5	50 ms
	6 to 10	100 ms
	11 to 20	200 ms
	21 to 50	500 ms
	51 to 100	1 s
	101 to 200	2 s
(* The number of channels of the GS/WL sensors is not included)		
Main module recording format-based limits (GL device limits)	GBD (binary)	10 ms
	CSV (Text)	10 ms

• **GL860**

Name	Explanation	
Limitations by amplifier (Limitations of the GL module side)	Number of CH available	Fastest sampling
	1	5 ms
	2	10 ms
	3 to 4	20 ms
	5 to 10	50 ms
	11 to 20	100 ms
	21 to 40	200 ms
	51 to 100	500 ms
	101 to 200	1 s
Limit by number of calculation CH settings (limitation on GL device side)	Number of CH available	Fastest sampling
	0 to 5	5 ms
	6 to 10	10 ms
	11 to 20	20ms
Main module recording format-based limits (GL device limits)	GBD (binary)	5 ms
	CSV (Text)	5 ms

• **GL980, GL2000**

Name	Explanation	
Recording destination-based limits (GL device limits)	Internal RAM	1 us
	Internal flash	1 ms
	USB memory	1 ms
Main module recording format-based limits (GL device limits)	GBD (binary)	1 ms
	CSV (Text)	1 ms

15-5. Trigger Settings

Set conditional trigger for the start and stop of recording.

15-5-1. GL7000, GL980, GL2000, GL860, GL260, GL240, GL840 and GLT400

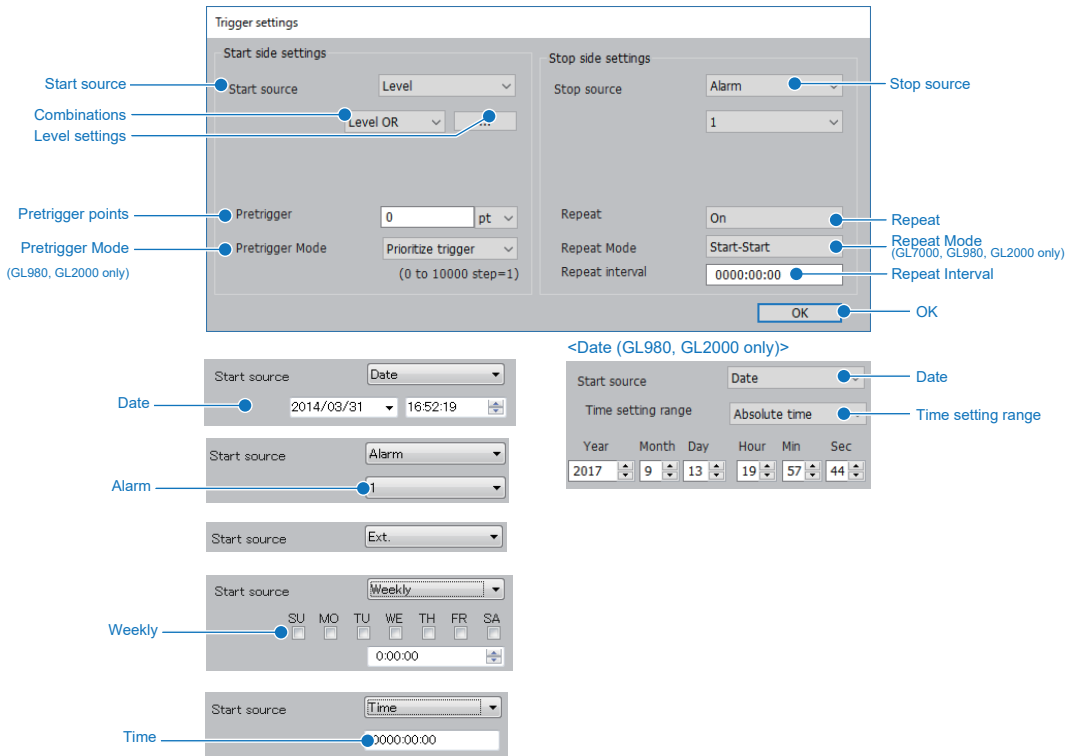

Name	Explanation	
Start/Stop source	Off	Starts unconditional recording. (There are no stopping conditions)
	Level	Starts (or stops) recording the designated channel's input signal once the set level's conditions are met.
	Alarm	Recording starts (or stops) once the designated alarm goes off.
	Date	Recording starts (or stops) once the designated date and time is reached. Active when repeat recording is off.
	Date (Daily)	Recording starts (or stops) once the designated date and time is reached. Active when repeat recording is on.
	External input	Recording starts (or stops) with the external trigger signal. There are approximately 2 external drive signals. Recording starts (or stops) when a fall under 5V is detected. *Both start/stop cannot be externalized when sampling is externalized (Other than GL7000).
	Weekly	Recording starts (or stops) on the set time and day.
	Time	Recording starts (or stops) when the specified time has lapsed.
Combinations	Set combinations for conditional level triggers for each channel. For details, refer to the user's manual in the CD-ROM or in the main unit memory.	
	Level	Requirements determine operation level.
	Edge	Requirements determine operation edge.
	OR	Recording starts (or stops) as long as at least one of the set level requirements is satisfied.
	AND	Recording starts (or stops) when all the set level requirements are satisfied.
Level	Set the level's determined requirements once the start/stop trigger's conditions are "leveled".	
Alarm	Set the start/stop requirements for the target alarm number once the alarm is set. Possible settings for alarm numbers may differ depending on the device.	
Date	Determines the start/stop requirements for the date once the "set date" is set.	
Weekly and Time	Configure with each trigger.	
	Date requirements	Used to to set the date and time.
	Time requirements	Used to to set the time.
	Weekly requirements	Used to to set the time and day.

Pretrigger points	Set data points for recording before a trigger is generated. The pre-trigger function can only set the recording destination to the internal RAM when the start source setting is off. (* This function is not provided in the GL860, GL260, GL240, GL840 and GLT400)	
	pt	Set sampling points.
	s	Set seconds.
	ms	Set milliseconds.
	us	Set microseconds.
Pretrigger Mode	Configures the operation mode of the pre-trigger.	
	Prioritize trigger	The trigger operation will be performed in the event that a trigger is generated while recording the pre-trigger.
	Prioritize pre-trigger	The trigger operation will not be performed until all of the pre-trigger points are recorded.
(*Applicable to GL980, GL2000, GL 7000 Ver. 2.00 or later)		
Repeat	Starts repeat recording once a trigger stop is generated.	
Repeat Mode	Configures the range of the repeat interval.	
	start - start	Configures the interval from the start of recording to the start of the next recording.
	stop - start	Configures the interval from the stop of the previous recording to the start of the next recording.
(*Applicable to GL980, GL2000 only, GL 7000 Ver. 2.00 or later)		
Repeat interval	Set time intervals between the time recording begins and the next repeat recording starts. Once a trigger stop is generated, instant repeat recording begins once the time of the existing repeat interval passes. (* This function is not provided in the GL860, GL260, GL240, GL840 and GLT400)	
Time setting range	Specifies the range of the time. (*Applicable to GL980, GL2000 only)	
OK	Closes the screen.	

* In the GL860, GL260, GL240, GL840 and GLT400 the repeat recording is performed in the GL-Connection side. Therefore, the settings of repeat recording are not obtained from the GL module. Also, the specified time when repeat recording is set to On cannot be set to the GL module.
CSV file data during playback do not see the value.

15-6. Alarm Settings

Configures alarm settings.

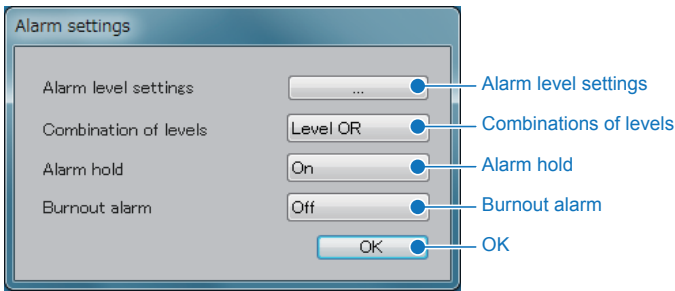

Name	Explanation								
Alarm level settings	Set requirements for alarm generation.								
Combination of levels	Set combination for alarm requirements for each channel. <table border="1" style="width: 100%; border-collapse: collapse;"> <tr> <td>Level</td> <td>Requirements determine operation level.</td> </tr> <tr> <td>Edge</td> <td>Requirements determine operation edge.</td> </tr> <tr> <td>OR</td> <td>Recording starts (or stops) as long as at least one of the set level requirements is satisfied.</td> </tr> <tr> <td>AND</td> <td>Recording starts (or stops) when all the set level requirements are satisfied.</td> </tr> </table> <p>Though alarm hold was set as Off when combination was edge OR/AND, as for the channel generated once, alarm continues holding alarm.</p>	Level	Requirements determine operation level.	Edge	Requirements determine operation edge.	OR	Recording starts (or stops) as long as at least one of the set level requirements is satisfied.	AND	Recording starts (or stops) when all the set level requirements are satisfied.
Level	Requirements determine operation level.								
Edge	Requirements determine operation edge.								
OR	Recording starts (or stops) as long as at least one of the set level requirements is satisfied.								
AND	Recording starts (or stops) when all the set level requirements are satisfied.								
Alarm hold	Set whether or not to clear or preserve a generated alarm status. <table border="1" style="width: 100%; border-collapse: collapse;"> <tr> <td>On</td> <td>Preserves alarm generation. Click "clear alarm" on the alarm window to clear all channels of alarms.</td> </tr> <tr> <td>Off</td> <td>Does not preserve alarm generation. Restores alarm status and output for each CH once the alarm status is released.</td> </tr> </table>	On	Preserves alarm generation. Click "clear alarm" on the alarm window to clear all channels of alarms.	Off	Does not preserve alarm generation. Restores alarm status and output for each CH once the alarm status is released.				
On	Preserves alarm generation. Click "clear alarm" on the alarm window to clear all channels of alarms.								
Off	Does not preserve alarm generation. Restores alarm status and output for each CH once the alarm status is released.								
Burnout alarm	Once this is set to On, an alarm will be generated in response to thermocouple connection temperature measurements registering burn out.								

* CSV file data during playback do not see the value.

15-6-1. Alarm Clear Button

Alarm Clear is only available during free-running or recording when alarm hold is On.

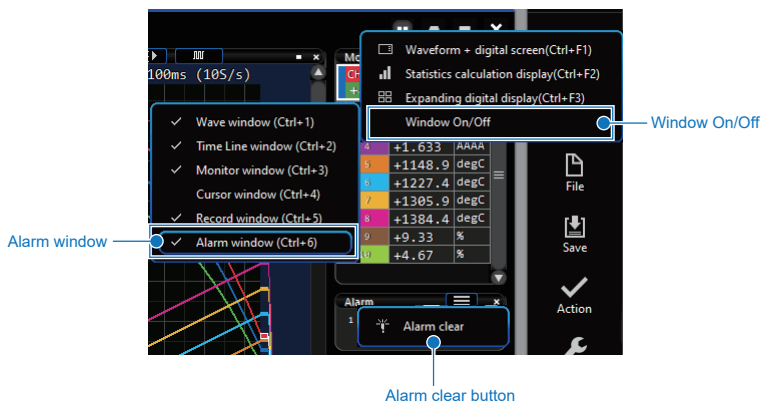

15-7. Marker Settings

This function inputs a mark to the unspecified position above the waveform during data recording. The inputted mark can perform searches and confirmations during playback. The inserted characters are configured here. By setting the characters before recording, you can insert other marks quickly and easily while recording (character marks can also be set during recording). Input marks while recording by using the “Input Mark” cursor operation button.

(* GL7000 only)

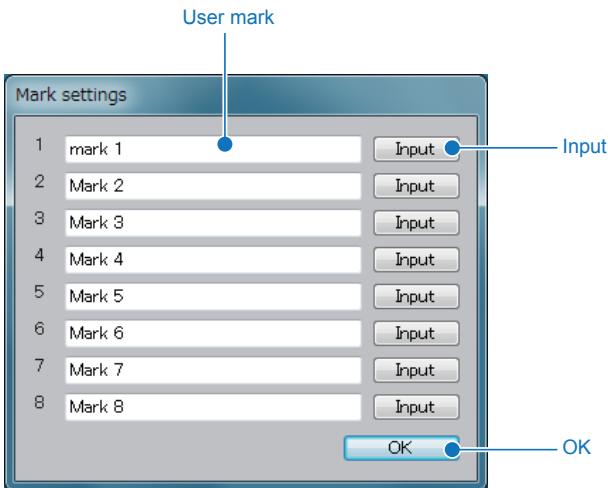

Name	Explanation
User mark	You can insert 1-8 unspecified characters. Up to a maximum of 30 characters can be entered. Marks inserted during recording will be saved; however, only the characters inserted last will be effective.
Input	Clicking the input button shows the location update on the upper-right hand side above the waveform where a user mark was inserted. The mark will show the inserted position during data playback.
OK	Clicking OK closes the screen. This transmits the user mark character information to the GL main module.

* CSV file data during playback do not see the value.

15-7-1. Display user mark during recording

Insert mark from the “insert mark” under the action panel in the control panel.

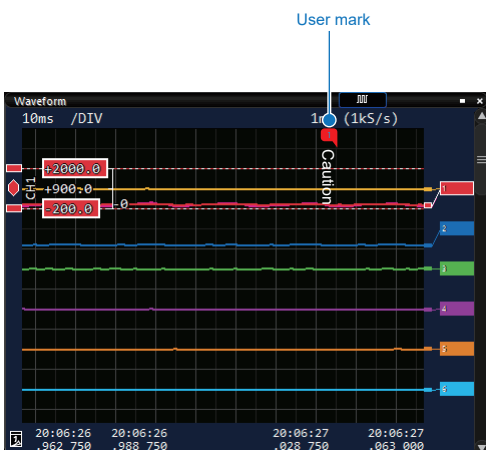

15-8. Option Settings

Perform option settings.

Name	Explanation
Room temperature compensation	Set room temperature compensation in response to thermocouple temperature measurements. Set internal temperature when the performs room temperature compensation. (Set interior to default) *Only effective with voltage/temperature modules.
Temperature unit	Unit of temperature for the temperature display can be changed between degrees of Celsius (° C) or Fahrenheit (° F) Only effective with *voltage/temperature modules.
AC line cycle	Set the power to the main module to the local area frequency. (50Hz or 60Hz) This effects denoising, so please set it correctly. For more details, please refer to the main module user's manual. *Only effective with voltage/temperature modules.
Burn out	Will carry out regular checks on the thermocouple connection break when set to On. Please use the thermocouple in OFF mode when other measuring devices are connected parallel to it, as it may effect other devices. A BURN OUT message will be displayed when a connection break is detected. *Only effective with voltage/temperature modules.
Power on start	Recording starts once power is applied to the main module. This setting operates only on the main module. Please set default to inactive.
Confirm Start / Stop	When turned on, confirmation messages are displayed when recording starts and stops. When turned off, starting and stopping is immediate.
Factory Initialization	The main module is set to factory settings. Initialization may occasionally take time. Please wait a little while.

15-9. Excel Settings

This function transmits data currently being recorded to Excel in real-time. Can be used to create original template files and reports, etc.

*Direct Excel functions cannot be used when the main module recording destination is the Internal RAM, or SSD module (option).

* Microsoft Excel (EXCEL2003 or later) is required for the use of main module.

* Transfers to the graph cannot exceed 32000 lines.

* Transfers to Excel may occasionally be incomplete depending on sampling and the number of channels.

If this occurs, please slow down sampling.

* Direct Excel data is output in batches every 10 seconds.

* If cells are input or edited during Excel transfer, they will not be output correctly.

* As a general rule, please use one Excel template per device.

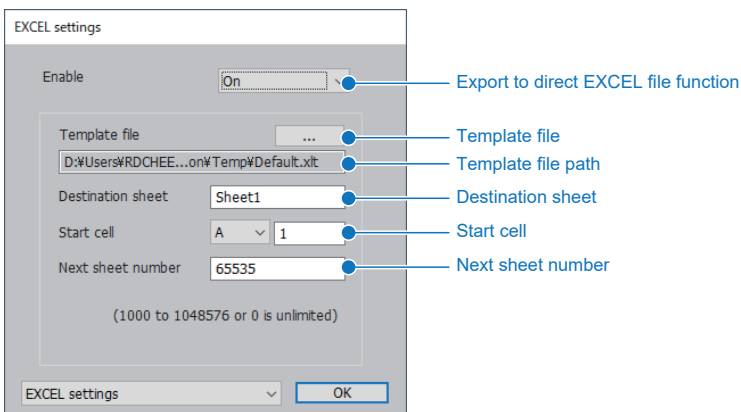

Name	Explanation
Expot direct EXCEL file function	Set direct Excel functions to On or Off.
Template file	Performs direct Excel transfer destination template settings. This can be used for "xlt" or "xltx" file types. Standard templates are available under the "Temp" folder under the main software's installed folder.
Template file path	Displays the template path.
Destination sheet	Set the sheet name for the designated template folder.
Start cell	Set the start cell the data will be transferred to.
Next sheet number	Transmits data to a differ sheet when it reaches a set points. * Graph may occasionally not operate correctly when transferred to a different sheet. * Can display up to 65536 lines on versions earlier than Excel 2007. * Can display up to 1048576 line on versions later than Excel 2007. * Cannot transmit more than 32000 points using graphing to a template.

15-10. X-Y Settings

A waveform display function that can be configured when displaying an X-Y waveform to assign an analog input channel to each the X axis and Y axis in order to show a correlation waveform. There are a maximum of 4 X-Y channels available that can be assigned respective unspecified analog channels. Furthermore, it can also perform span and position controls, etc.

(* Does not support pulse input. The GL980, GL2000, GL860, GL260, GL240, GL840 and GLT400 are not possible to communicate with the GL module for the settings.)

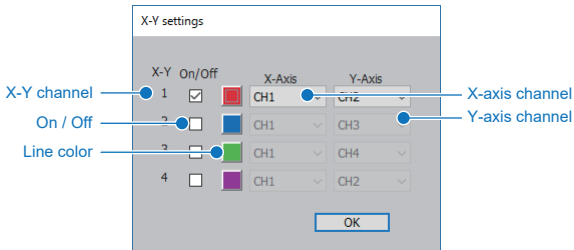

Name	Explanation
X-Y channel	Displays the X-Y channel number.
On / Off	Switches each X-Y channel On/Off.
Line color	Displays the X-Y waveform color.
X axis channel	Displays the analog channel assigned to the X axis.
Y axis channel	Displays the analog channel assigned to the Y axis.

15-11. FFT Settings

You can perform the FFT settings to display the FFT Waveform.

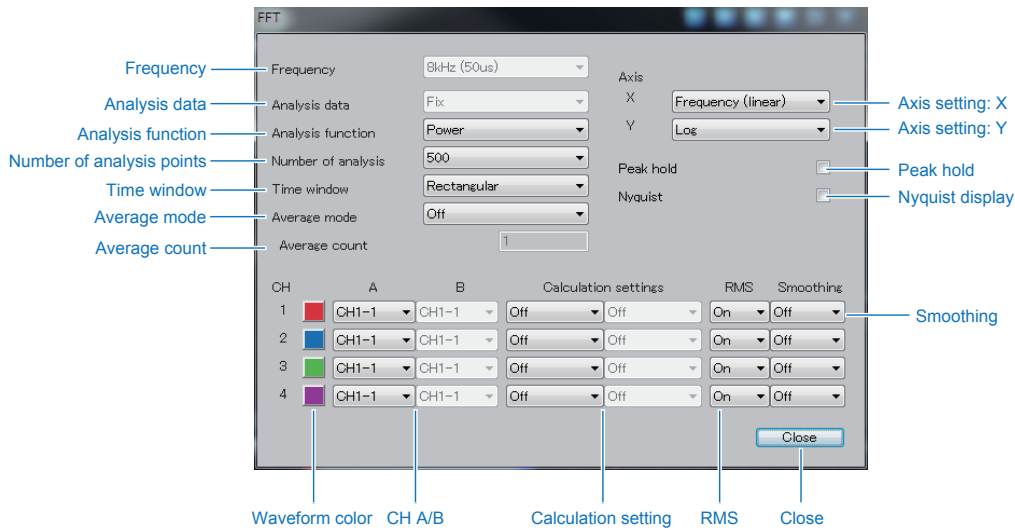

Name	Explanation
Frequency	Set the analysis frequency.
Analysis data	Select the analysis data. Fix: The number of analysis points will be newly processed every time. Move: In this process, the number of analysis points is increased or decreased as a moving average.
Analysis function	Select the analyzing function. Linear, Power, PSD, Cross, TRF (transfer function), Coherence, COP (coherence output power), and Y-T can be set.
Number of analysis points	Set the number of analysis points to be recorded in a single measurement. The number of analysis points can be set to one of 500, 1000, 2000, 4000 and 10000.
Time window	Set the Time window. Select one of Rectangular, Hanning, Hamming, Blackman, Flattop and Exponential for the Time window.
Average mode	Set how to perform the averaging process. The averaging process varies depending on the state. During free running or recording: Off, Summation (moved), Summation (fixed), Exponential (fixed) During viewing: Off, Summation (fixed), Exponential (fixed)
Average count	Set the average count. The range between 2 and 999 can be set as the average count.
Axis setting: X	Set the scale on X axis. Frequency (linear), frequency (logarithm), period (linear), period (logarithm) can be selected.
Axis setting: Y	Set the scale on Y axis. Linear, LOG or Phase can be selected
Peak hold	Set On/Off for the Peak hold. When On is set, the maximum and minimum values at the analysis point are filled and then they are displayed.
Nyquist display	Changes to the Display Mode of the Nyquist diagram.
CH A/B	Set the channel to be analyzed with each analyzing function. When CH A only is used: Linear, Power, PSD, Y-T When CH A/B is used: Cross, TRF, Coherence, COP
Calculation settings	Set this settings to the channel only set to Linear, Power, PSD, Cross, TRF, Coherence, COP in the settings of the analyzing function. None, Differential, D-Differential, Integral and D-Integral can be selected as the settable calculation.
RMS	Set this settings when Linear, Power, PSD, Cross is set in the analyzing function setting. Set On/Off for RMS. The default is On.

Smoothing	For the calculation result of the FFT, perform the moving average with arbitrary frequency width, and then smooth the waveform. The frequency width can be selected in the items calculated from the analysis frequency and the number of analysis points.
Close	Closes the window.

15-11-1. Analyzing Function

- **Linear (Linear Spectrum)**

Based on the results of the time axis data processed with FFT calculation, the amplitude or phase of each frequency is displayed.

- **Power (Power Spectrum)**

Based on the results of the time axis data processed with FFT calculation, the power of each frequency component is displayed.

- **PSD (Power Spectrum Density)**

The power spectrum per unit interval of frequency is known as PSD. Since the results of the FFT analysis is the value of integral for the spectrum distributed on the bandwidth (Range of the frequency resolution) determined from the analysis frequency and number of analysis points, the power spectrum of the signal such as a continuous spectrum is a value that varies depending on the settings of the analysis frequency range and the number of analysis points. When there is the signal that the spectrum is distributed in such a broad band and the signal is measured with the power spectral density, the cross spectrum measured regardless of the analysis frequency range and the number of analysis points is multiplied by the spectrum of two signals for each frequency component, and the magnitude of the power and the correlation of two signals are displayed.

- **Cross (Cross Spectrum)**

The cross spectrum measured is multiplied by the spectrum of two signals for each frequency component, and the magnitude of the power and the correlation of two signals are displayed. The cross spectrum allows you to reduce greatly the effects of noise, as compared with the case where only the power spectrum of the output signal is measured, by averaging the measured cross spectrum of the input and output signals even if there are a system that the noise is mixed in the input signal.

- **TRF (Transfer Function)**

The TRF showing the relationship between the input and output signals can be determined by calculating the ratio of the cross spectrum of the input and output signals and the power spectrum of the input signal. Similar to the cross spectrum, the averaging process allows you to reduce the effects of noise mixed in the system. However, the input signal contains frequency component across the analysis frequency is required to measure the TRF across the analysis frequency.

- **Coherence (Coherence Function)**

Coherence (Coherence Function)

The coherence is determined by calculating the ratio of the squared amplitude of the cross spectrum of the input and output signal and the product of the power spectrum of the input and output signals, and then the causal relationship between the input and output signals are displayed. The value of the coherence function is between 0 and 1. When the coherence function is 1, all the output signal is caused by the input signal, and when it is 0, the output signal is independent of the input signal at all. The measurement of the coherence function allows you to confirm the reliability of the measurement, such as the TRF. Note that,

when the averaging process is not performed, all the value of the coherence function is 1. When using the coherence function, make sure to perform the averaging process.

- **COP (Coherent Output Power)**

The product of the coherence function and the power spectrum of the output side is displayed.

- **Y-T**

When X Axis is fixed to the Time, Y Axis is fixed to the Linear, the change of the input signal with respect to the time axis is displayed.

15-11-2. Time Window

- **Desidctions of Time Window**

The input signal to be FFT analyzed is an infinite continuous signal, however only the signal within the finite time called Time window in infinitely continuous signal is subject to analysis. In FFT mode of the module, there is the following relationship to the time window length and analysis frequency.

$$\text{Time Window Length} = \frac{0.4}{\text{Frequency [Hz]}} \times \text{Number of analysis points [sec.]}$$

- **Rectangular**

No action is taken for the signal that is cut away with the time window. When the time window is used to cut the normal continuous waveform, the signal is affected by cutting with the Time window. However, when using the signal such that the length of waveform and time window match to an integer multiple of the period by attenuating within the time window, the result not affected by the time window can be obtained.

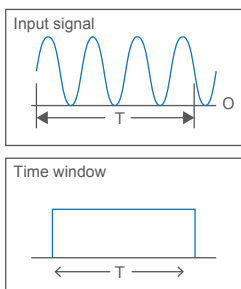

- **Hanning**

The time window displays so that the input signal is zero smoothly at start and end points in consecutive. Since the input is zero at both ends of the time window, even if the continuous waveform is cut, the effects of the cut can be minimized.

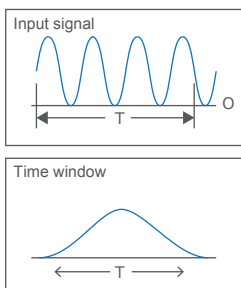

- **Hamming**

The hamming window is suitable to separate the signals in close proximity in comparison to the Hanning window. Make an attempt to use the Hamming If you can not improve sufficiently the frequency resolution.

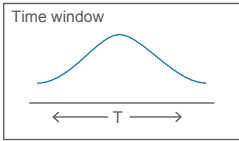
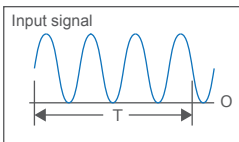

- **Blackman**

The frequency resolution is lower than Hanning and Hamming, however even the smaller signal can be analyzed because of a wider dynamic range.

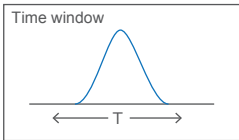
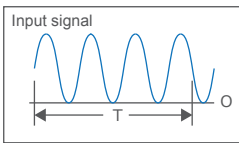

- **Flattop**

The amplitude can be accurately measured by flattening the peaks with the low ripple time window function.

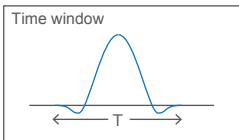
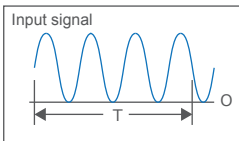

- **Exponential**

Since this exponential is asymmetrical, it is used to perform the time asymmetric waveform analysis such as echo detection.

15-11-3. Average Mode and Average Count

The noise component contained in the signal can be removed by performing the averaging process. The averaging process varies depending on the state. The summed moving average can be performed during free running or recording. You can check the waveform in quick response without having to wait for the processing of the number of analysis points each time. This function is easy to use because the average count between the cursor A and B is automatically calculated.

- **During free running and recording**

Summation (Moving)

When the average count is 6 times and the number of analysis points is 500 points

The averaging process is performed moving every point for the number of data (500 points x 6 times).

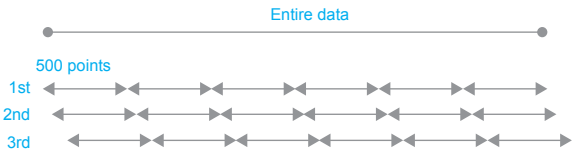

Summation (fixed)

When the average count is 6 times and the number of analysis points is 500 points
 FFT process stops when the averaging is performed six times.

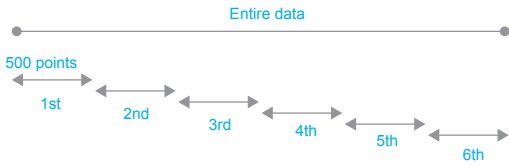

Exponential (fixed)

When the average count is 6 times and the number of analysis points is 500 points
 The weight to be added is reduced as the average count progresses.

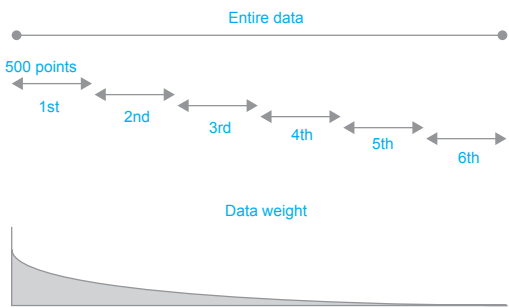

• **During viewing**

Summation (fixed)

When the number of analysis points is 500 points
 During viewing, the number of times of the accounts between the cursor A and B divided by the number of analysis points is automatically set as the average count (6 times in the figure).

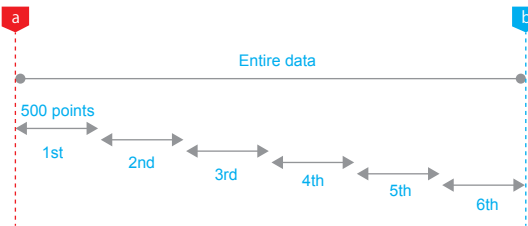

Exponential (fixed)

When the number of analysis points is 500 points

During viewing, the counts between the cursor A and B divided by the number of analysis points is automatically set as the average count (6 times in the figure).

The weight to be added is reduced as the average count progresses.

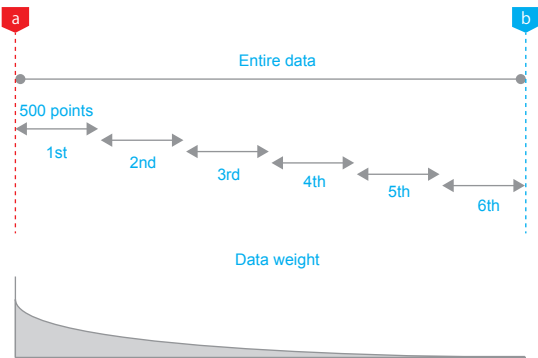

15-12. Mail Settings

You can send emails when an alarm is generated.

- * This requires an environment capable of sending emails.
- * Emails may not be sent depending on the sending email server's security system.
- * Email transmission function effective only during recording.
- * Emails cannot be transmitted during free-running even if an alarm is generated.
- * Because the system does not transmit large volumes of email, no further emails can be sent for 1 minute after an email is sent. Alarms generated during periods where email is not being sent will send them based on the timing of the next transmission.

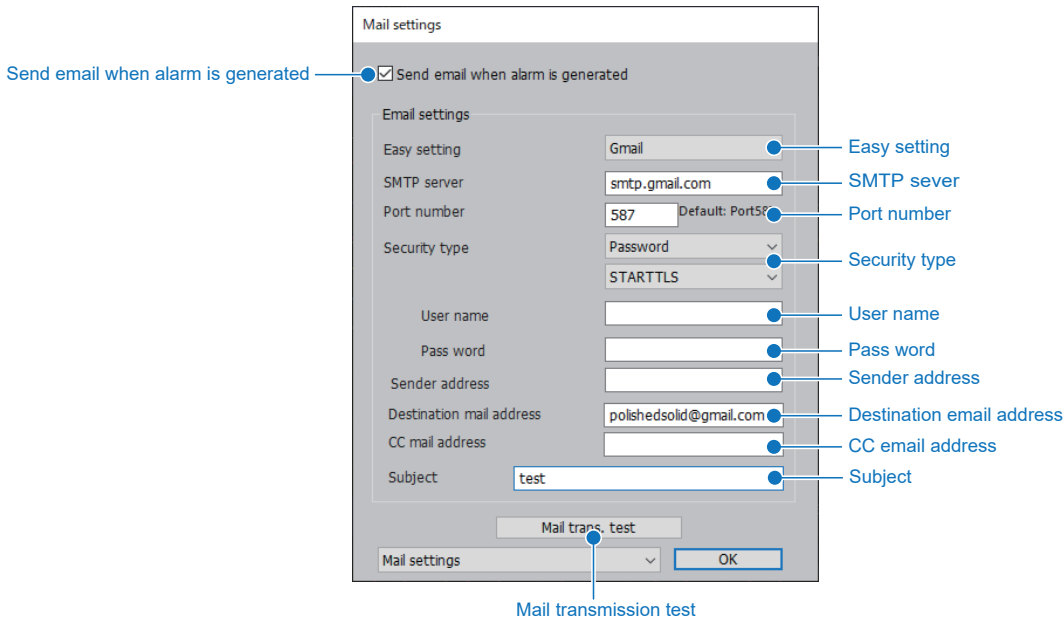

Name	Explanation
Send email when alarm is generated	Checking off "✓" mark generates an alarm during recording, which then sends emails to the set email address.
Easy setting	Easy configuration of default SMTP servers. Manual settings, Easy Mail Settings, Yahoo.com, Yahoo.jp, Gmail, Office365 Easy Mail Settings allows you to send e-mail using the mail server provided by our company. * When using Easy Mail Settings, only the destination email address, CC email address, and subject line are set. * You cannot enter the sender address, outgoing mail server, user name, or password.
Sender address	Set the sender's email address.
SMTP server	Set the transmitting email server (SMTP). Port number Sets the port number. The port number settings may differ depending on the security type.
Port number	Set the port number. The port number settings may differ depending on the security type.

Security type	Set security settings as needed depending on the transmitting email server. For security settings, please confirm the email server transmission.	
	None	There is no security.
	Plain-text passwords	Security is not tight with plain-text password and they flow through the network.
	LOGIN	Security is a little higher because plain-text passwords flow through the network one character at a time, separately.
	CRAM-MD5	Plain-text passwords that are not shared throughout the network are the safest ones.
	Encryption settings	
	None	Will not encrypt.
	TLS/STARTTLS	A system that encrypts data exchanged during e-mail transmission to protect it from eavesdropping and tampering by third parties.
User name	Set security authentication when required.	
Pass word	Set security authentication when required.	
Destination email address	Set the transmission destination for emails.	
CC email addresses	Set the transmission destination for CC emails.	
Subject	Set the email subject.	
Mail transmission test	Performs a test transmission	

• **Alarm Mail Sample**

```
An alarm occurred.
Alarm channel
Date,2024-04-0112:00:00,200
CH1, CH 1,DC,100V,+5.95V
CH2, CH 1,DC,100V,+5.36V
83,2024-04-01
12:00:00,200,+5.95,+5.36,+4.76,+4.17,+3.57,+2.98,+2.38,+1.78,+1.19,+0.59,HLLLLLLLLL,LHLL
```

15-13. I/F Setting

Configure USB and LAN setting.

- * When connected via USB, only IP can be set.
- * When connected via LAN, only USB ID can be set.
- * GL240 USB ID only
- * IP setting is not available for GL260 and GL240.
- * GL860 and GL260 only reference the settings.

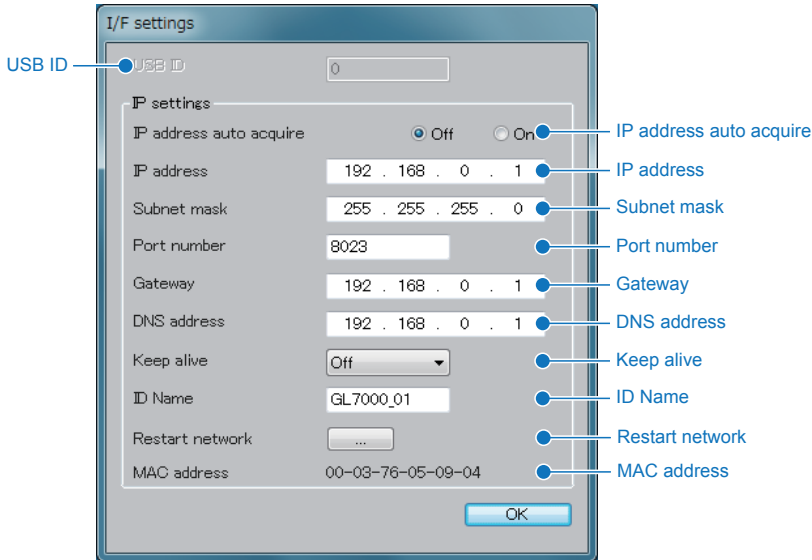

Name	Explanation
USB ID	Set USB ID number. Please make sure not to copy USB ID when connecting a single PC to multiple devices via USB.
IP address auto acquire	Set automatic IP acquisition. A server that is able to assign functions to the connecting network is required.
IP address	Set the IP address.
Subnet mask	Set the subnet mask.
Port number	Set the port number.
Gateway	Set the Gateway address.
DNS address	Set the DNS address.
Keep alive	When set to anything other than Off, the socket connection will be severed automatically if a period of non-transmission time is detected.
ID Name	Set the device's identifier.
Restart network	Applies IP settings. The connection will be forcibly severed during set- up. It may occasionally take about 1 minute to apply the settings.
MAC address	Displays the MAC set to the device.

16. Other functions

Introduction to other useful functions.

16-1. Data Compressing Function

- Data compressed file

The compressed file leaving the peak signals is created based on the recorded file. This file is used for improving the response of the waveform display during viewing. This software automatically creates 1/10, 1/100 or 1/10000 compressed file. Even if the data compressed file is deleted, the recorded data is not affect.

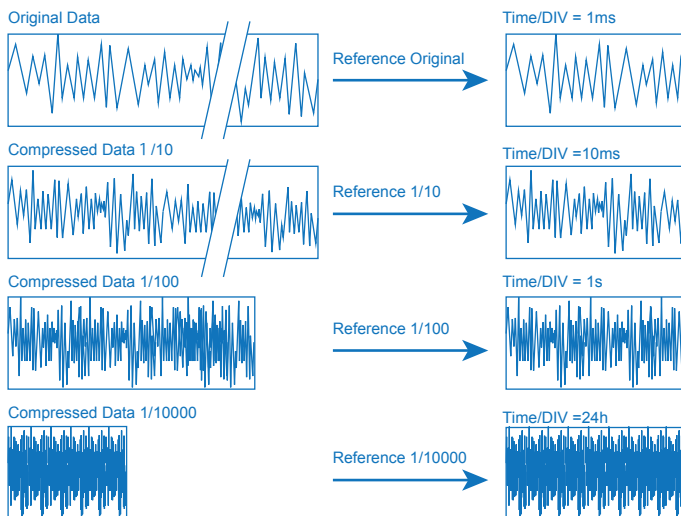

- **Creation of data compressed file**

The data compressed file is created using the following method.

- When performing the data recording with PC: The compressed file is automatically created separately from the recorded file.
- When PC file is replayed: If there is no existing compressed file, the compressed file is automatically created. When PC file is replayed and then the compressed file is created, the processing state is displayed in the Help window.



The data compressed file is saved in “My document → Graphtec → GL-Connection → Data→ Comp” folder.

(* Even if the compressed file is deleted, the recorded data is not affected. Additionally, all the compressed files are deleted by performing “Control Panel → Initializing.”)

- **Viewing of the data compressed file**

If the data compressed file has been created already when viewing the PC file, the data compressed file is read in accordance with the Time/DIV settings. Usually, the file viewing and the data compressed file are automatically determined and switched without being aware of it. When the PC file is replayed and then the data compressed file is created, the appropriate compressed file will be displayed at the time the creation was completed. To check the compressed file applied during viewing, check the following screen.

Compressed file confirmation

- (1/1) Compressed file
- (1/10) 1/10 Compressed file
- (1/100) 1/100 Compressed file
- (1/10000) 1/10000 Compressed file



16-2. Group functions

Many different waveform display methods are possible using group and screen section functions. Group function creates copies of basic display tabs. It is possible to analyze signals by setting up original tabs and copied tabs independently. It is possible to perform different Time/DIV settings, span and stretch settings, Y-T waveform, and X-Y waveforms, etc.

16-2-1. Types of group functions

Name	Explanation
Free running/Recording In Progress group	Data can be grouped by the free-running or recording tab. It is possible to mix identical families of data. Data cannot be mixed if it is under the data playback tab. (* The data in the data replay tab can not be mixed.) (* The data on X-Y and FFT waveforms can not be mixed.)
Data playback group	This group plays back data. It is possible to mix data from PC playback and the main module playback tab. Data cannot be mixed if it is under the data playback tab. (* The data in the data replay tab can not be mixed.) (* The data on X-Y and FFT waveforms can not be mixed.)

16-2-2. Method of group creation

Name	Explanation
Creates from tab copy	Creates group tab by copying displayed tab. Copies monitor channel and waveform display information under the same requirements. <ul style="list-style-type: none"> •Free-running/recording tab→ free-running/recording group •Data playback tab→ data playback group 
Creates from Monitor channel	Groups are created from the chosen monitor channel. <ul style="list-style-type: none"> •Free-running/recording tab→ free-running/recording group •Data playback tab monitor channel→data playback group 

Adds group tab monitor channels

Provided the group is of an identical family, it is possible to mix different tabs with the monitor channels.

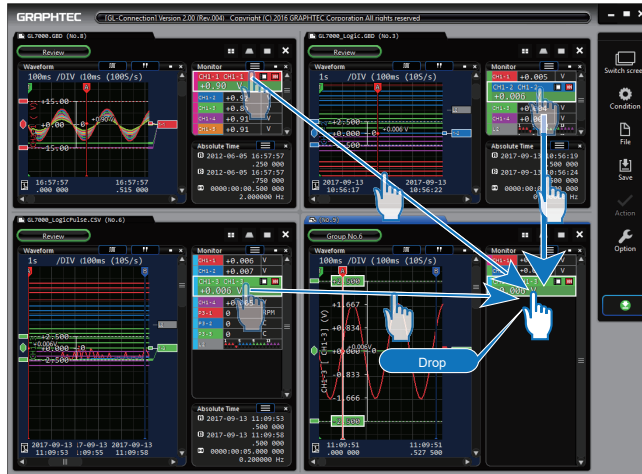

Deletes group tab monitor channels

Choose more than 1 monitor channel when deleting monitor channel group tabs. Can select multiple monitor channels separately by pressing the PC's shift key to select two points or by using the Ctrl key to select individually. Once they are selected, drag them to the recycle bin using the mouse.

Multiple Selection
(Shift Key)

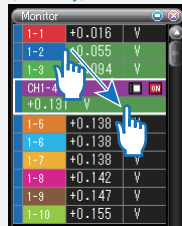

Multiple Selection
(Ctrl Key)

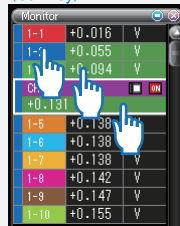

Delete

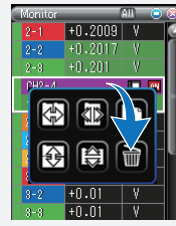

16-2-3. Example of Group use

Here is an example using the group function.

* Group tab settings are not saved by this application or the GL device.

Example 1. Y-T Display and Wide Monitor Display



- 1) Copy the free running group tab and create a free running group.
- 2) Separate the free running group to the bottom
- 3) Wide monitor display for the free running group

Example 2. Y-T Display and X-Y Display

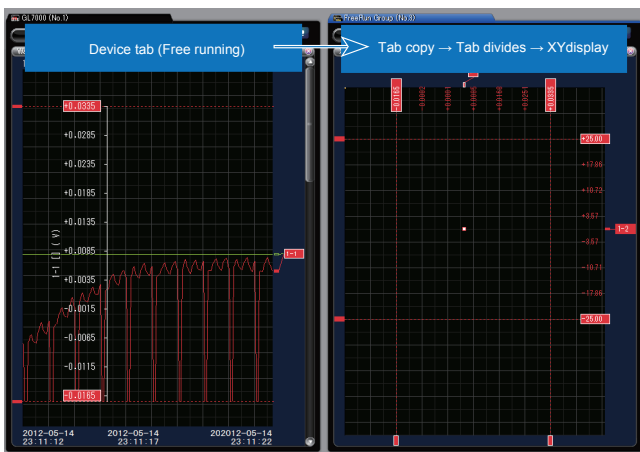

- 1) In X-Y free running mode, copy the tab contains the free running group from Navigation Window, and then create the other group tab.
- 2) Separate the free running group to the right from Navigation Window.
- 3) Switch the free running tab to the Y-T display by pressing the Y-T switch button.

16-3. Inter-CH calculation function (Ver.2.00 or later)

Via the group function, an inter-CH calculation function that performs calculations between different CHs can be utilized.

With inter-CH calculation, the four arithmetic operations, multiplication using any coefficient, addition of constants, conversion of units, and alteration of waveform colors, etc. can be performed between CHs.

16-3-1. Types of inter-CH calculation

Name	Explanation
Inter-CH calculation with free-running and recording groups	Inter-CH calculations can be performed between CHs of the tab for free-running or recording. (*Calculations cannot be performed for CHs of different devices.) (*Data from the data playback tab cannot be calculated.) (*Data from X-Y and FFT waveforms cannot be calculated.)
Inter-CH calculation with data playback groups	Inter-CH calculations can be performed between CHs of a data playback group. (*Calculations cannot be performed for CHs of different files.) (*Data from the free-running/recording tab cannot be calculated.) (*Data from X-Y and FFT waveforms cannot be calculated.)

16-3-2. Operation Procedures

• Creating an inter-CH calculation CH

When using the CH drag and drop operation



1) Create a group tab for the free-running tab with which the inter-CH calculation will be performed.

2) Select the CHs of the group tab that will be subject to the calculation. In the image to the left, CH1 has been selected.

3) Select the CH subject to calculation from the free-running tab and move the CH to the group tab by dragging the CH display portion.

4) Since the tab will switch to the group tab, drag the CH to the place where CH1 is on the group tab.

5) When the CH is dragged, the icon will switch to an arithmetic operation mark so this is where you will drop the CH.

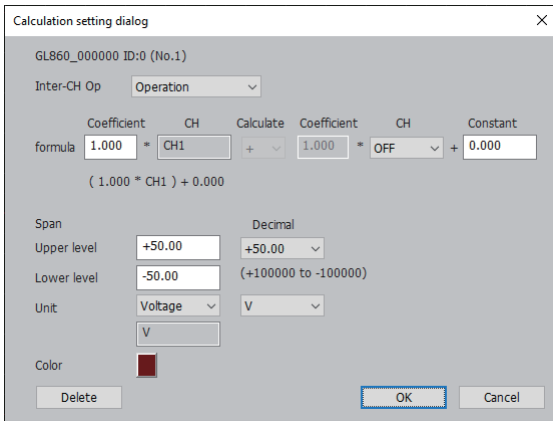

6) Since the inter-CH calculation settings dialog will open, apply appropriate settings and click OK to confirm the entry.



7) CH1 on the group tab will become the calculation CH and the results of calculations with CH1 and CH2 will be displayed.

When using the right-click operation



1) Create a group tab for the free-running tab with which the inter-CH calculation will be performed.



2) Select the CHs of the group tab that will be subject to the calculation. In the image to the left, CH1 has been selected.

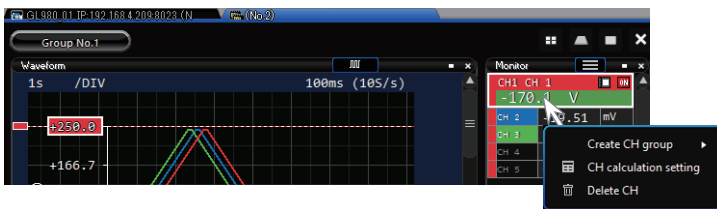

3) Right-click on CH1 on the group tab to display the context menu and select inter-CH calculation settings.

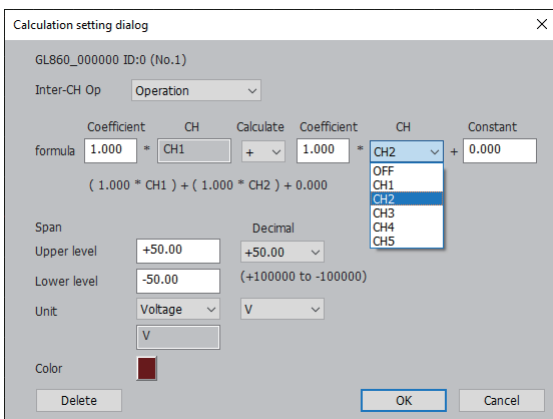

4) The inter-CH calculation settings dialog will open. When performing an inter-CH calculation by right-clicking, the setting is "Off" since the calculation CH on the right side has not yet been established. Select any CH you want to use, appropriately configure the calculation settings, and click OK to confirm the entry. In the image to the left, CH2 has been selected.



5) CH1 on the group tab will become the calculation CH and the results of calculations with CH1 and CH2 will be displayed.

• Changing an inter-CH calculation CH



1) By clicking on the display of a CH for which inter-CH calculation is available, the inter-CH calculation dialog will appear.

Calculation setting dialog

GL860_000000 ID:0 (No.1)

Inter-CH Op Operation

Coefficient	CH	Calculate	Coefficient	CH	Constant
1.000	CH1	+	1.000	OFF	0.000

formula (1.000 * CH1) + 0.000

Span Upper level Decimal +50.00
 Lower level (+100000 to -100000)

Unit Voltage V

Color

Delete OK Cancel

2) Apply appropriate settings and click OK to confirm the change.

• Deleting an inter-CH calculation CH



1) By clicking on the display of a CH for which inter-CH calculation is available, the inter-CH calculation dialog will appear.

Calculation setting dialog

GL860_000000 ID:0 (No.1)

Inter-CH Op Operation

Coefficient	CH	Calculate	Coefficient	CH	Constant
1.000	CH1	+	1.000	OFF	0.000

formula (1.000 * CH1) + 0.000

Span Upper level Decimal +50.00
 Lower level (+100000 to -100000)

Unit Voltage V

Color

Delete OK Cancel

2) Click the delete button to delete the inter-CH calculation.

Settings and display

- Calculation formula

When "Inter-CH Op" is selected for the Operation.

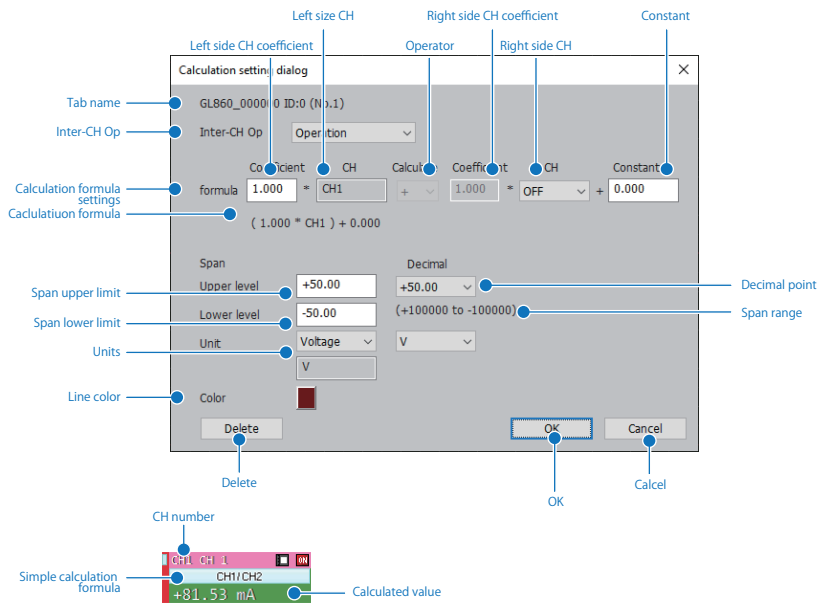

Name	Explanation
Tab name	Displays the name of the tab that will serve as the source of the calculation.
Inter-CH Op	Select the calculation settings. Operation / 4-point input
Calculation formula setting	Configures the calculation.
Left side CH coefficient	Configures the coefficient to multiply the left side CH by.
Left side CH	Displays the left side CH. Settings cannot be changed.
Operator	Select the arithmetic operator.
Right side CH coefficient	Configures the coefficient to multiply the right side CH by.
Right side CH	Configures the right side CH. A selection can be made only from the CHs of the source of calculation. Only an analog CH can be selected.
Constant	Configures the constant to add.
Calculation formula	Displays the calculation formula.
Span upper limit	Decides the upper limit value of the span when displaying the waveform of the calculation result.
Decimal point	Configures the decimal point of the calculation results. As calculations are performed using a fixed unit (e.g.: calculating mV with V) with inter-CH calculation, the result may become smaller or larger depending on the calculation. In such case, adjust the position of the decimal point. Otherwise, adjustments can also be made using a coefficient.
Span lower limit	Decides the lower limit value of the span when displaying the waveform of the calculation result.
Span range	Displays the configured range of the span.
Units	Configures the units of the calculation results.
Line color	Configures the line color of the waveform.
Delete	Deletes the inter-CH calculation.
OK	Enables the setting and closes the screen.
Cancel	Disables the setting and closes the screen.
CH number	Displays the CH number.
Simple calculation formula	Displays a simplified version of the calculation formula. By clicking this, the calculation setting dialog will appear.
Calculated value	Displays the value of the calculation result.

- 4-point input

When "Inter-CH Op" is selected for the 4-point input.

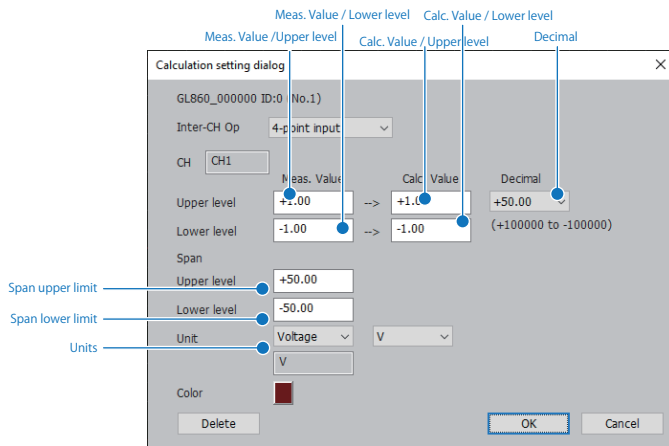

Name	Explanation
Meas. Value / Upper level	Sets the upper limit on the measured value side.
Meas. Value / Lower level	Sets the lower limit on the measured value side.
Calc Value / Upper level	Sets the upper limit on the arithmetic value side.
Calc Value / Lower level	Sets the lower limit on the arithmetic value side.
Decimal	Sets the decimal point of the calculation result.
Span upper limit	Decides the upper limit value of the span when displaying the waveform of the calculation result.
Span lower limit	Decides the lower limit value of the span when displaying the waveform of the calculation result.
Span range	Displays the configured range of the span.
Units	Configures the units of the calculation results.

16-3-3. Restore status

Under the following conditions, the inter-CH calculation settings are also restored the next time this software is launched.

Name	Explanation
When using manual connections	Only the channels of inter-CH calculation are restored. (*As the status of when this software was previously ended is saved, the status will not be restored in cases when the software has not been closed properly.) (*Other CH that are not for inter-CH calculation will not be restored.)
When using automatic connections	The channels of inter-CH calculation and other channels are all restored. (*As the status of when this software was previously ended is saved, the status will not be restored in cases when the software has not been closed properly.)
When playing files playing files recorded on PC with CH operation enabled	A file group tab is generated upon playback of the playback file of a file that has been recorded on a PC while in the state where inter-CH calculation is enabled, and only the inter-CH calculation channels are restored. (*Other CH that are not for inter-CH calculation will not be restored.) (*Inter-CH operation channels are restored for GBD files only.)

16-3-4. Save data file

By pressing the save data button on a tab that includes an inter-CH calculation during playback, you can save the results of an inter-CH calculation.

The calculation CH of saved data is converted to a normal CH and the calculation information is discarded.

*Due to limitations of internal data, the inter-CH calculation may exceed upper/lower limits. In such case, make adjustments with the decimal point or coefficient under the inter-CH calculation settings.



16-4. Remote lock release function (Ver.2.00 or later)

A function for temporarily releasing the operation lock of the main unit during control with this software in order to change settings and perform recording operations.

16-4-1. Applicable models

GL860, GL260, GL980, GL2000, GL7000 Ver.2.00 or later

• Procedures for changing settings

Temporarily release the operation lock of the main unit during control with this software and change the settings.



1) In the free-running state, hold down the MENU key on the main unit for 3 seconds. (You will hear a BEEP.)
(In GL7000 HOME key)

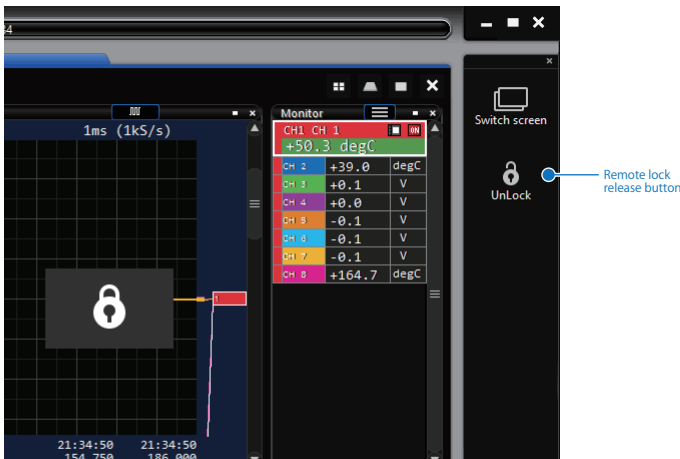

2) The applicable tab of GL-Connection will enter the state where the remote lock is released and it will no longer be possible to perform operations. It will still be possible to operate those other than the applicable device tab.

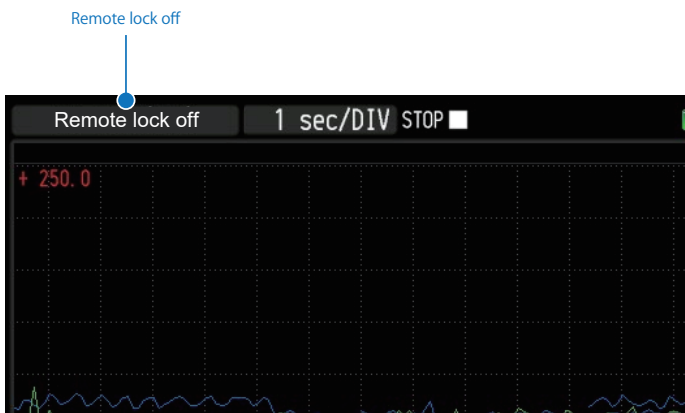

3) Operations of the main unit can be performed while the remote lock is released. Starting and stopping a recording cannot be performed with these procedures.



4) Once you are done operating the main unit, in order to end the remote lock release, hold down the MENU key on the main unit again for 3 seconds. (You will hear a BEEP.)
(In GL7000 HOME key)

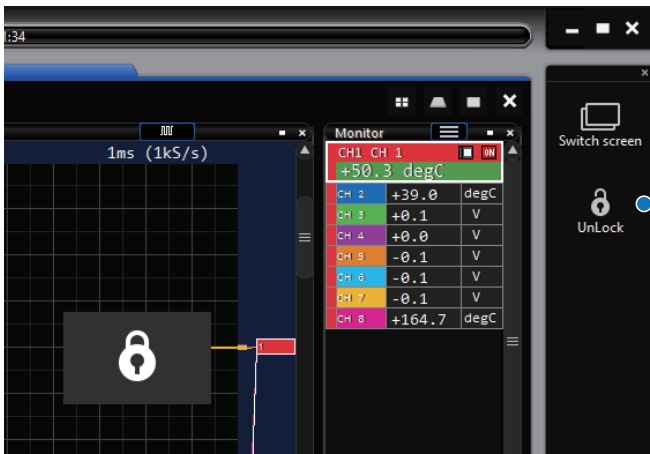

5) It is also possible to force the remote lock release to end from this software. By pressing the remote lock release button shown in the image to the left, a process similar to 4) above is performed.

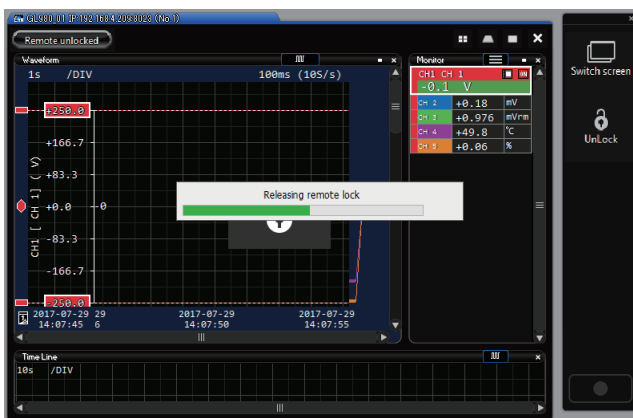

6) Upon receiving a notification from the main unit that the remote lock release has ended, the setting change status of devices will be loaded with this software.

7) The unit will enter the normal state and it will be possible to perform operations with this software.

* Only one device can be changed at the same time.

- **Procedures for starting and stopping a recording**

Start and stop a recording from the main unit during control with this software.

Starting a recording



1) In the free-running state, hold down the START/STOP key on the main unit for 3 seconds. (You will hear a BEEP.)



2) This software and the main unit will start recording.

Stopping a recording



1) In the recording state, hold down the START/STOP key on the main unit for 3 seconds. (You will hear a BEEP.)

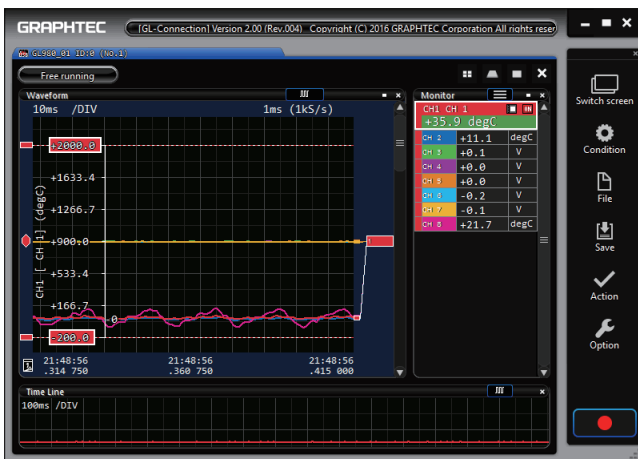

2) This software and the main unit will stop recording

16-5. Dual samplign function (Ver.2.20 or later)

The dual sampling function can only be utilized when the GL7000 (version 2.00 or later) and this software (version 2.20 or later) are used in combination.

Normally, the input signal recorded data is saved on a single storage medium over the single sampling interval. However, as the dual sampling function allows the recording of both high- and low-speed data on two separate storage media over the dual sampling interval, it is possible to record both highly-accurate data with pinpoint precision at high speed and long-term data at a low speed.

16-5-1. Dual sampling function setting conditions

These conditions determine allowable settings for low- and high-speed recording.

Item	Low-speed recording	High-speed recording
Name	Current recording	Event recording
Sampling interval	1/2/5/10/20/50/100/125/200/250/500ms/ 1/2/5/10/20/30sec/ 1/2/5/10/20/30min/1hour	1/2/5/10/20/50/100/200/500μs
Destination	Internal Flash, SD card	Internal RAM, SSD unit (Optional) *1 When using dual sampling recording, the Internal RAM allows a single recording while the SSD module allows up to 100 recordings.
Recorded files	<ul style="list-style-type: none"> • Dual sampling file (*.DSA) This file is generated in the same location as the current (low-speed) file. It contains management information for the current (low-speed) file and the event (high-speed) file. For dual sampling playback, please select the dual sampling file. • Current (low-speed) file (*.GBD) As these have the same format as GBD files for normal recording, playback as a standalone file is also possible. 	<ul style="list-style-type: none"> • Event (high-speed) file (*.GBD) As these have the same format as GBD files for normal recording, playback as a standalone file is also possible.
Timer / Trigger	Start side: On/Off ** hour *** min Stop side: On/Off ** hour *** min Repeat: On/Off	This is treated in the same manner as the trigger settings for normal recording. * Repeat recording is disabled if the Internal RAM is set as the event (high-speed) recording save location.

* Limitations

- External sampling cannot be used for both low and high speeds.
- The CSV file format cannot be set for both current (low-speed) and event (high-speed) recording.
- Ring/relay recording cannot be used.
- Synchronized control of multiple GL7000 units is not possible.
- Multi-instrument connection recording with multiple devices can not be performed.

- The number of events recorded at the high-speed (event) recording save location

Internal RAM: 1 recording

SSD module: Up to 100 recordings

When the internal RAM

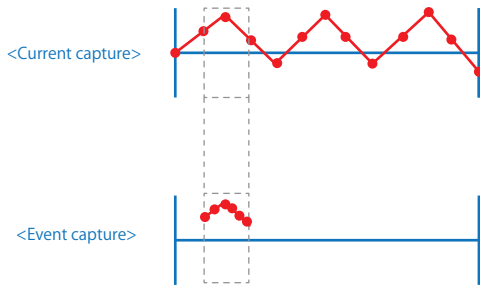

When the SSD module

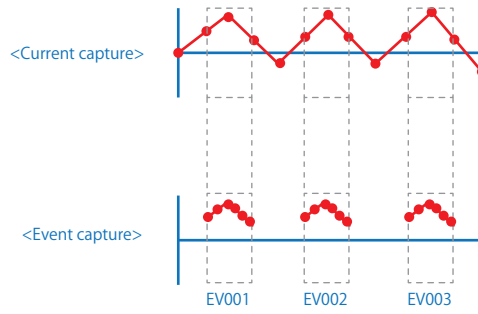

16-5-2. Dual sampling data recording

When using this software for dual sampling recording, it is not possible to record in real time as data is first saved on the GL7000 unit and transferred to the PC only after recording is complete.

- **Dual sampling settings**

- 1) Configures the dual sampling settings for the main unit.
- 2) Sets the current (low-speed) sampling and save location (internal flash memory or SD memory card).
- 3) Sets the event (high-speed) sampling and save location (internal RAM or SSD module).
- 4) Sets the event (high-speed) trigger.

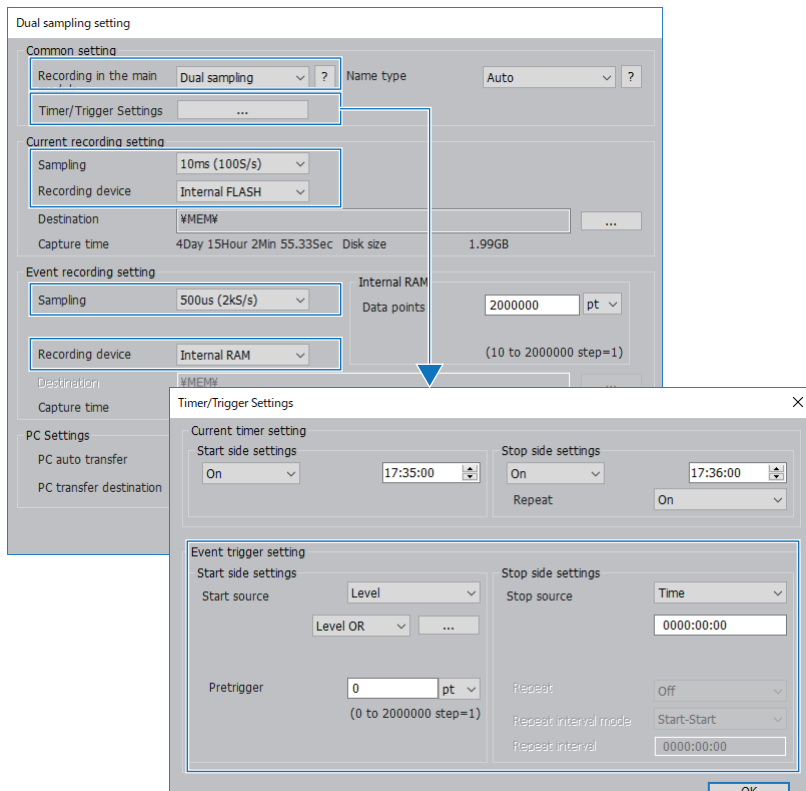

- 5) Starts recording.

During recording, it is possible to check the status of the current (low-speed) and event (high-speed) recording from the recording information window.



- 6) Recording is stopped upon operation of the recording stop button.
- 7) As automatic PC transfer is turned on by default, automatic transfer will start after recording stops. Press the transfer button to bring up the transfer details screen. Press the cancel button to stop the data transfer.

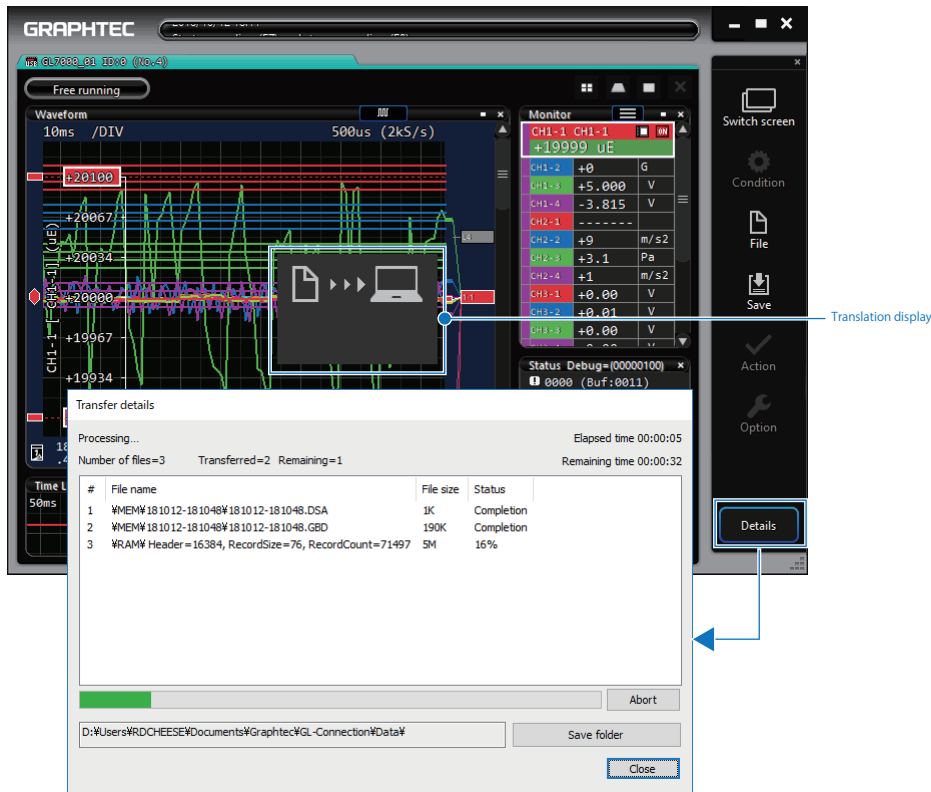

16-5-3. Dual sampling data playback

Dual sampling playback can be performed by opening a dual sampling file (*.DSA).

- 1) Select "Control Panel" > "File" > "Review PC" and then select the recorded dual sampling file.

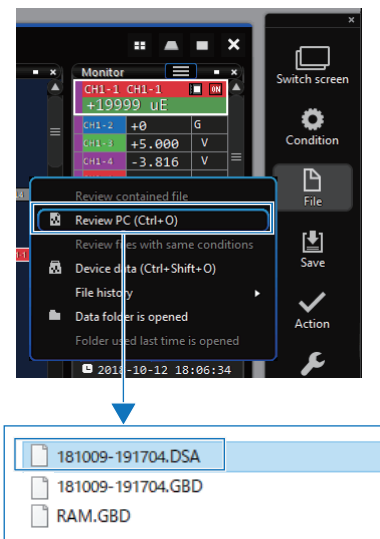

- 2) When playing back the dual sampling file, both the current (low-speed) data and the event (high-speed) data tabs are generated at the same time.

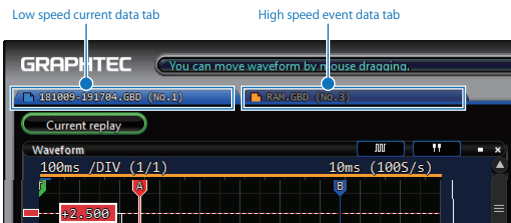

3) To check the current (low-speed) data and the event (high-speed) data simultaneously, right-click the event (high-speed) data tab and select "move to the left and right sides" to split the screen.

4) An orange bar is displayed toward the top of the current (low-speed) data screen. This indicates that event (high-speed) data is present at the position of this bar. If you move the cursor on the current data screen over the event data bar, the event data corresponding to the event (high-speed) data tab is automatically played back. * The event data that is closest to the cursor is played back.

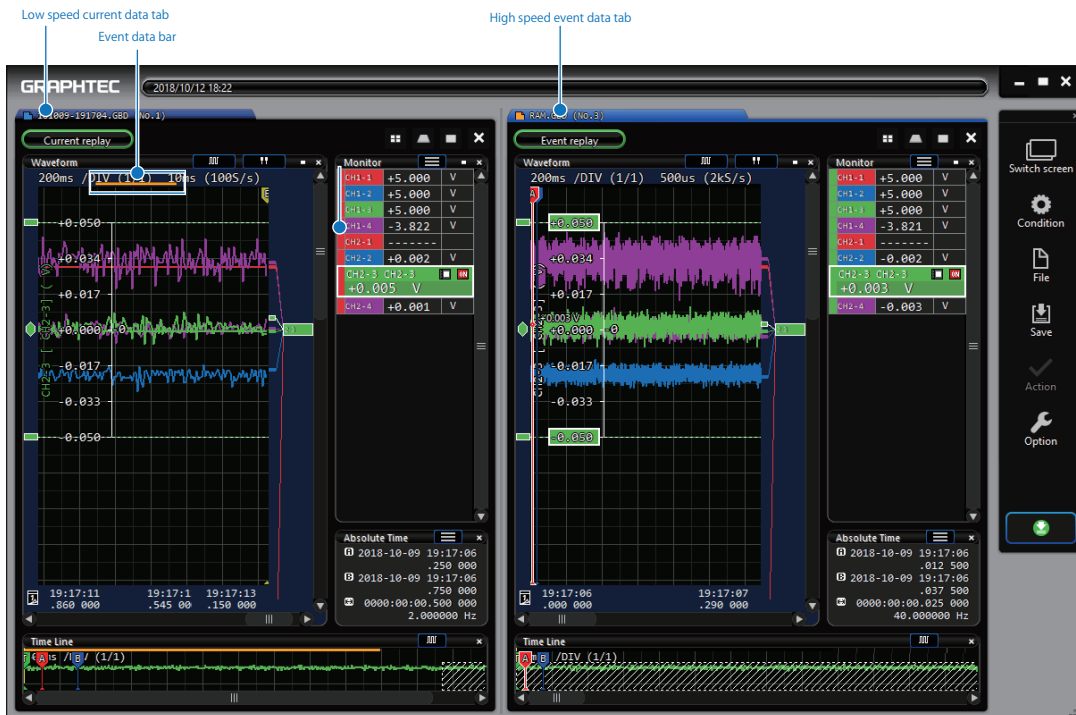

5) When you move the cursor on the current (low-speed) data screen or the event (high-speed) data screen, the cursors on other screens move in conjunction.

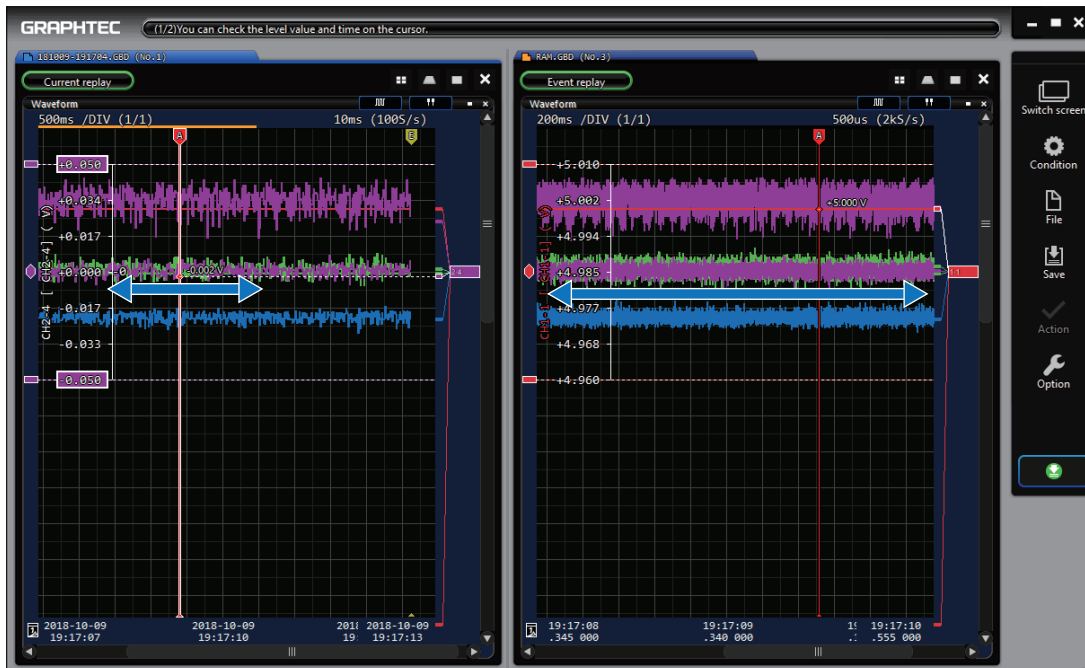

6) To end the playback, both playback screens are closed if you press the [X] button on the upper-right of either screen.

16-6. Image display function (Ver. 2.40 and later)

This is a function that displays log data and image files in sync. During Y-T display playback, the function searches for an image that corresponds to the time at cursor A/B and displays it in the image window. The image search is performed based on the timestamp in the image file name, so the file name must contain timestamp information. The minimum timestamp interval of image files is 1 minute.

16-6-1. Configuring the image display function

The function can be enabled in the image display function settings of options on the control panel. This setting is applied to data files played back after applying the setting.

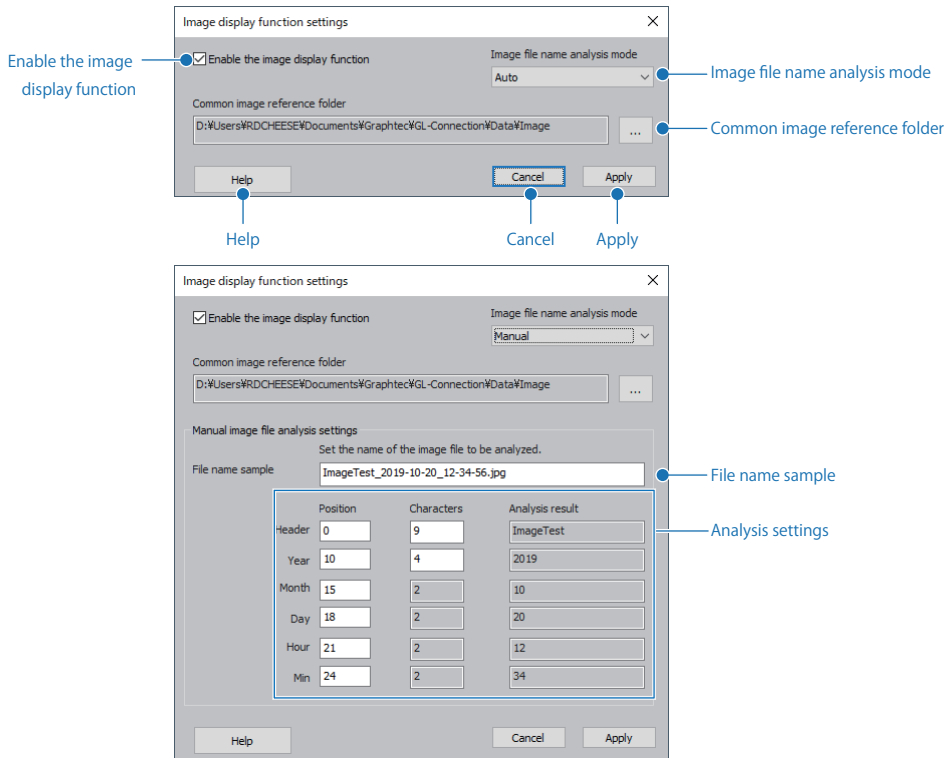

Name	Explanation
Enable the image display function	Selecting the check box enables the image display function.
Image file name analysis mode	Auto The timestamp is analyzed automatically from the file name. Normally, use this mode.
	Manual If the timestamp cannot be analyzed automatically from the file name, date/time can be set manually. See the analysis parameters of the manual image file analysis settings.
	For details, see section "16-6-2. About the image file timestamp information".
Common image reference folder	Set the default path to the image file reference location. For details, see section "16-6-3. Referenced location of log data files and image files".
Apply	Applies the settings and closes the window.
Cancel	Closes the window without applying the settings.
Help	Displays a help for this function.
File name sample	If the image file name analysis mode is set to Manual, enter the file name in this box, and assign the position and the number of characters of each parameter in the analysis parameters. For details, see section "16-6-2. About the image file timestamp information".
Analysis settings	Enter the position and the number of characters of each parameter in order to calculate the date and time from the file name entered in the file name sample.

16-6-2. About the image file timestamp information

JPEG image files captured with a general network camera, digital camera, or the like can be displayed. To search for the image file based on the time at the cursor position during Y-T display playback, the image file names must contain timestamps. This function allows you to set the image file name analysis mode to Auto or Manual.

Example) Image_20190619_123155 (Image_YYYYMMDD_hhmmss)

In addition, file names are automatically analyzed for the following formats.

- photo_YYYYMMDD_hhmm**.jpg
- Image_YYYYMMDD_hhmm**.jpg
- PYYMMDDhhmm****.jpg

* indicates any character.

Image file name analysis is performed down to the minute unit. Thus, the minimum image interval is 1 minute.

For file names that are not compatible with auto analysis, the position and the number of characters of each time unit can be specified manually. Correct analysis may not be possible if the year is two digits.

Example of a manual file) ImageTest_2019-10-20_12-34-56.jpg

File name	I	m	a	g	e	T	e	s	t	_	2	0	1	9	-	1	0	-	2	0	_	1	2	-	3	4	-	5	6	.	j	p	g
Start position	0	1	2	3	4	5	6	7	8	9	10	11	12	13	14	15	16	17	18	19	20	21	22	23	24	25	26	27	28	29	30	31	32

Item	Start posion	Length	Analysis result
Header	0	9	ImageTest
Year	10	4	2019
Month	15	2	10
Day	18	2	20
Hour	21	2	12
Minite	24	2	34

16-6-3. Referenced location of log data files and image files

To synchronize log data files with images, arrange the files using one of the following two methods.

Method 1: To synchronize images with each log data file

Images can be synchronized with log data files by storing the log files and image files to specific folders in the following manner. Place the Logger folder and Image folder in the same folder, and store the log data files and image files in the respective folders.

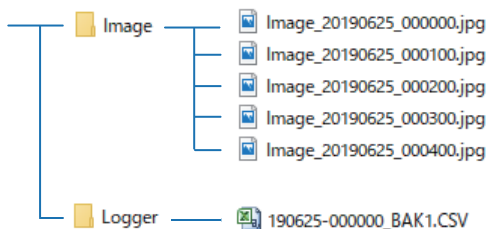

- The Logger folder also supports the following types of file names. Logger* Example: Logger001, LoggerTest
- Subfolders in the Logger folder and Image folder are also searched.

Method 2: To synchronize with the common image reference folder

If folders structured in the manner explained in Method 1 do not exist, images in the common image reference folder are searched.

The common image reference folder can be placed at any location. Log data files can be stored anywhere.

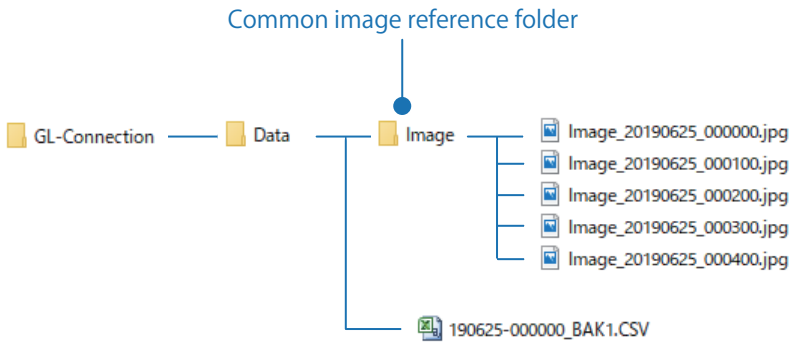

16-6-4. Displaying the image window

When the image display function is enabled, an image window can be shown in any of the file playback tabs. For the procedure, see section "11-10. Image window (Ver. 2.40 and later)". An image window can also be shown in the file playback group tab.

- Standard image window and maximized window



- When a file playback group tab is created and an image window is shown maximized in the group tab side

For efficiency, it is possible to separate the data and image displays in the file playback tab and file playback group tab. In this setup, the tab cursor sync function can be enabled to synchronize the cursors on the file playback tab and file playback group tab and synchronize the image displays as well.

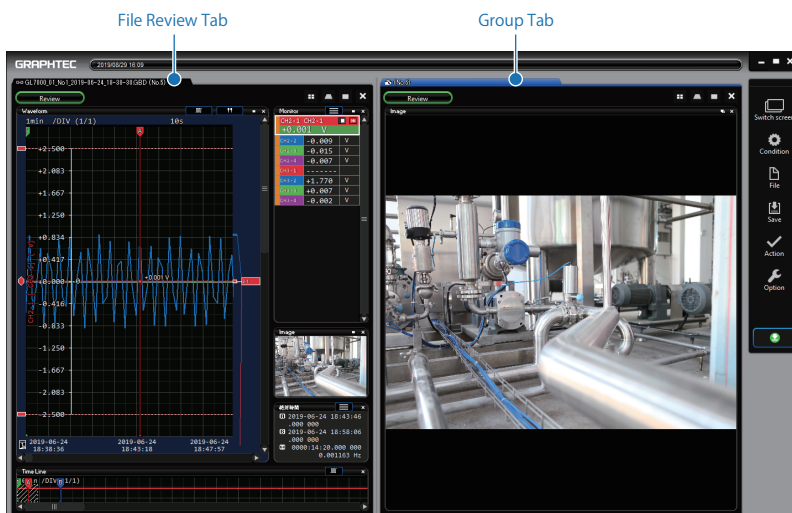

16-6-5. Synchronizing log data and image files

- **Synchronizing with cursor A/B**

When log data and image files are synchronized, the image corresponding to the time at cursor A/B in the waveform window during Y-T waveform display or cursor A/B in the timeline window is displayed.

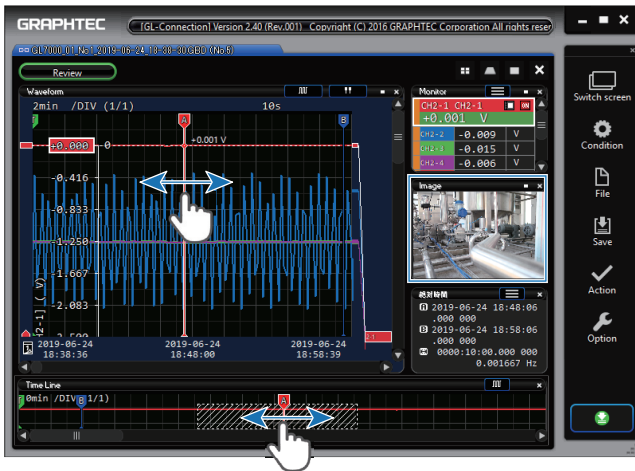

- **Synchronizing using the image switch buttons**

When you place the mouse cursor on an image window, image switch buttons appear. You can use the left and right buttons to switch to the previous and next image. When you switch the image, the active cursor moves in sync to the time of the image.

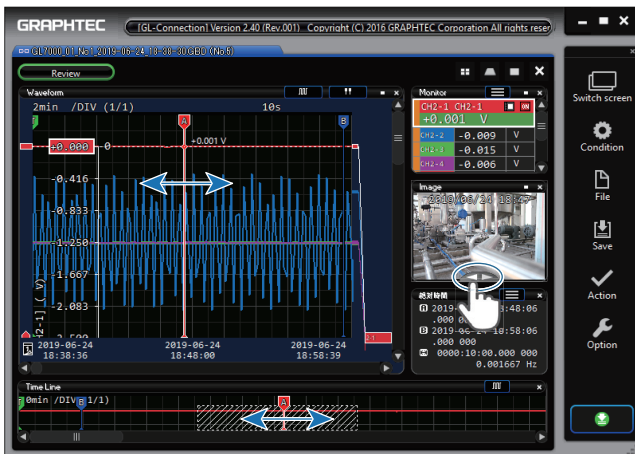

- **Image file search range**

The image file search range is from the timestamp of the first log data to that of the last log data.

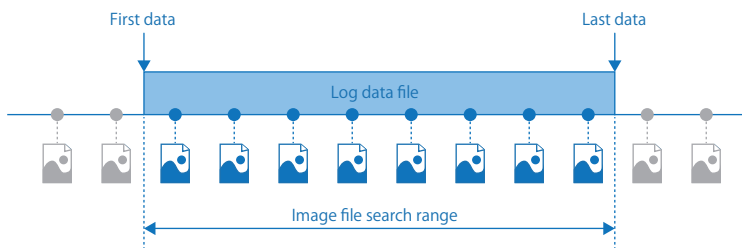

- **Data timestamp and image file timestamp**

Image files are searched from the time at the data cursor toward the past.

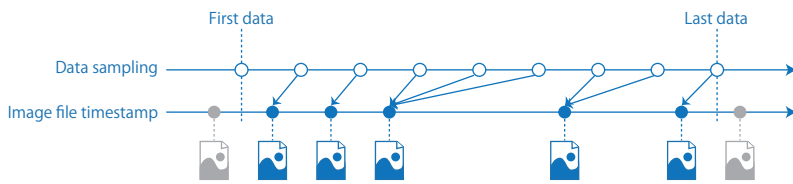

If there are multiple images in the data sampling period, the image with the closest timestamp is searched for.

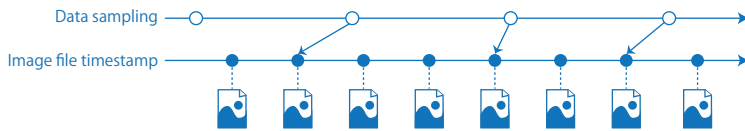

* Note

The image of the first data is not displayed.

If the data sampling period and the image file timestamp do not match, the time difference between the two is shown on the image.

- Specifications are subject to change without notice.

GL-Connection User's Manual
APS (GL-Connection) -UM-160-01
July 1, 2026

GRAPHTEC IWATSU Test Instruments Co.,Ltd

GRAPHTEC